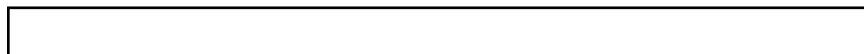



TABLE OF CONTENTS

SOLID CARBIDE SPIRALS	FLUSH TRIM BITS	GROOVE PROFILING
Up Cut..... 2	Solid Carbide Spiral Flush Trims . 2	Round Nose 9
Down Cut..... 2	Double Flute Flush Trim..... 14	V-Groove 10
Chipbreaker..... 2	Double Bearing Flush Trim..... 14	Plunge Roundovers 12
Flush Trim Spirals 2	V-Groove Flush Trim..... 14	Plunge Ogee 24
Left Hand 2	Overhang Trim..... 14	Classic Round Bottom 24
Roughing (Hoggers)..... 3	Three Flute Flush Trim 14	Classical Flat Bottom 24
Three Flute 3	Downshear Flush Trim..... 14	Train Track Bits 24
Slow Spiral..... 3	Combination Flush Trim..... 14	
Up/Down (Compression) 3		CABINET MAKING
O-Flute Spirals..... 3		MDF Door Bits 25
SOLID CARBIDE	LAMINATE TRIM BITS	Stile & Rail 26
Plastic 0-Flute..... 4	Solid Carbide Trimmers 4	Raised Panel 27, 28
Straight Bits 4	Ball Bearing Trimmers 15	Panel Back Cutter..... 28
Flush Laminate Trim..... 4	Combination Flush or Bevel..... 15	Vertical Panel Bits 28
7° Laminate Trim..... 4	Square Bearing Laminate Trimmers.. 15	Door/Drawer Edge 29
Hole & Flush Trim 5		Drawer Pull 29
Rip & Slotting 5	SOLID SURFACE BITS	
Veining 5	Round Over 16	WINDOW BITS
Carving Liner 5	Round Under 16	Window Sill Edge..... 29
Fiberglass..... 5	Face Inlay 16	Window Sash..... 30
Screw Slot Bits..... 5	Round Over Undermount 16	
	Bevel Undermount Bowl 16	DOVETAILS 30, 31
	Overhang Bowl Trim 16	CNC SPOILBOARD SURFACING ... 32
		SLOTTING
STRAIGHT BITS	PROFILE BITS	Slotting Cutters/Arbors 32
Solid Carbide Straight Bits..... 4	Template Bits 17	Drawer Slot Cutters/Arbors 32
CNC Straight Bits..... 6	Keyhole 17	Slotting & Rabbeting 11
Left Hand 6	T-Slot 17	T-Slot 17
Carbide Tipped Straight Bits..... 6,7	Undercut Bits 17	Slot & Undercut 17
Dado Bits 7	Classical Cove 18	
Staggertooth..... 8	Wavy Edge..... 18	DOWEL DRILLS 33
Up/Down Staggertooth..... 8	Radius Flute Cutter 18	BORING BITS 33
Mortise 8	Full Bead..... 18	ACCESSORIES
Helix Mortise Cutters/Arbors 8	Multi-Beading 18	Router Collets..... 32
Panel Bits..... 10	Double Round 18	Solid Carbide Knives..... 32
Staggertooth Panel 10	Cove & Bead..... 19	Inlay Kit..... 34
Flush Trims..... 14	Ogee Fillet 19	Base Plate Reducers 34
Template Bits 17	Ogee..... 19	Square Corner Chisel..... 34
	Classical Pattern 19	Quick Change Chucks 34
FORM TOOLS	Edge Beading 19	Extension Adapter 34
Bowl & Tray..... 9	French Traditional..... 19	Set-Up Gauge Blocks..... 34
Round Nose 9	French Provincial Molding 20	Arbors..... 34
Half Round..... 9	Table Top Edges 20	Shim Washer Kit 34
Hand Grip 9	Handrail 21	Bearings..... 35
Oval Edge 9	Specialty Molding 21	Spare Parts 35
V-Groove 10	Classic Multi-Form..... 21	
Point Cutting Round Over..... 10	GLUE JOINTS	ROUTER BIT SETS 36
Cove..... 10	Locking Drawer Glue Joint 22	DOOR LITE BITS IBC
Rabbeting 11	Standard Glue Joint..... 22	
Biscuit Joining..... 11	45° Lock Miter 22	
Round Over 12	Wedge Tongue & Groove 22	
Beading 12	Straight Tongue & Groove 22	
Plunge Roundover..... 12	Vee Panel Tongue & Groove 23	
Roundover & Edge Trim..... 12	Tongue & Groove Assembly 23	
Double Round Over 13	Fine Finger Joint..... 23	
Roman Ogee 13	Multi-Side Bits..... 23	
Chamfer 13		
Edge Bevel 13		





SOLID CARBIDE SPIRALS

STANDARD SPIRAL BITS

Up Cut or Down Cut
Solid Carbide - Two Flute



PART # RUS125

Up Cut Part Number	Down Cut Part Number	Cutting Diameter	Cutting Length	Overall Length
1/4" SHANK				
RU1600	RD1600	1/8"	1/2"	2"
RU1700	RD1700	5/32"	5/8"	2"
RU1800	RD1800	3/16"	3/4"	2 1/2"
RU1900	RD1900	7/32"	3/4"	2 1/2"
RU2075	RD2075	1/4"	3/4"	2 1/2"
RU2100	RD2100	1/4"	1"	2 1/2"
5/16" SHANK				
RU3100	RD3100	5/16"	1"	2 1/2"
3/8" SHANK				
RU4075	RD4075	3/8"	3/4"	2 1/2"
RU4100	RD4100	3/8"	1"	2 1/2"
RU4125	RD4125	3/8"	1 1/4"	3"
1/2" SHANK				
RU4675	RD4675	1/4"	3/4"	3"
RU4700	RD4700	1/4"	1"	3 1/4"
RU4800	RD4800	9/32"	1"	3"
RU4850	RD4850	5/16"	1"	3"
RU4875	RD4875	3/8"	3/4"	3"
RU4900	RD4900	3/8"	1 1/4"	3"
RU4950	RD4950	7/16"	1 1/4"	3"
RU5100	RD5100	1/2"	1"	3"
RU5125	RD5125	1/2"	1 1/4"	3"
RU5150	RD5150	1/2"	1 1/2"	3 1/2"
RU5200	RD5200	1/2"	2"	4"
5/8" SHANK				
RU6150	RD6150	5/8"	1 1/2"	3 1/2"
RU6200	RD6200	5/8"	2"	4"
3/4" SHANK				
RU7150	RD7150	3/4"	1 1/2"	4"
RU7200	RD7200	3/4"	2"	4"
RU7300	RD7300	3/4"	3"	5"
RU7306	RD7306	3/4"	3"	6"

CHIPBREAKER SPIRAL BITS

Up Cut or Down Cut
Solid Carbide - Two Flute



PART # RD5150CB



Up cut Part Number	Down cut Part Number	Cutting Diameter	Cutting Length	Overall Length
1/2" SHANK				
RU5125CB	RD5125CB	1/2"	1 1/4"	3"
RU5150CB	RD5150CB	1/2"	1 1/2"	3 1/2"
RU5200CB	RD5200CB	1/2"	2"	4"

The above items are available from stock with chipbreakers. Chipbreakers can be added to any Spiral Bits by request.

FLUSH TRIM SPIRAL BITS



PART # RFTD1600



PART # RFT5125



These spiral bits offer State-of-the-Art results in Flush trimming. Our 1/4" diameter tools are great for small inside corners. Try our 1/8" diameter for extremely sharp corners. The 1/8" bit uses a solid pilot. All others feature a double ball bearing guide. Available in your choice of Up Cut, Down Cut, or an Up/Down Combination.

Up Cut Part #	Down Cut Part #	Cutting Diameter	Cutting Length	Overall Length
1/4" SHANK				
RFT1600	RFTD1600	1/8"	3/8"	2"
RFT2100	RFTD2100	1/4"	1"	3"
1/2" SHANK				
RFT5125	RFTD5125	1/2"	1 1/4"	3 3/4"
RFT5200	RFTD5200	1/2"	2"	4 3/4"

FLUSH TRIM UP/DOWN CUT SPIRAL



PART # UDFT5152

Up/Down Cut (2+2 Compression)

Solid Carbide - Two Flute

Part Number	Cutting Diameter	Cutting Length	Shank Diameter	Overall Length
UDFT5152	1/2"	1 1/2"	1/2"	4 1/4"

LEFT HAND SPIRAL BITS

Up Cut or Down Cut
Solid Carbide - Two Flute



PART # LU5125



Up Cut Part Number	Down Cut Part Number	Cutting Diameter	Cutting Length	Overall Length
1/4" SHANK				
LU1600	LD1600	1/8"	1/2"	2"
LU1800	LD1800	3/16"	3/4"	2"
LU2100	LD2100	1/4"	1"	2 1/2"
5/16" SHANK				
LU3100	LD3100	5/16"	1"	3"
3/8" SHANK				
LU4100	LD4100	3/8"	1"	3"
1/2" SHANK				
LU5125	LD5125	1/2"	1 1/4"	3"
LU5200	LD5200	1/2"	2"	4"
5/8" SHANK				
LU6200	LD6200	5/8"	2"	4"
3/4" SHANK				
LU7200	LD7200	3/4"	2"	4"



SOLID CARBIDE SPIRALS

ROUGHING SPIRAL BITS

(Hoggers)

Up Cut or Down Cut

Solid Carbide - Three Flute



PART # RU5162H

Up Cut Part #	Down Cut Part #	Cutting Diameter	Cutting Length	Shank Diameter	Overall Length
*RU4000H		3/8"	1"	3/8"	2 1/2"
RU4100H	RD4100H	3/8"	1"	3/8"	3"
RU4125H	RD4125H	3/8"	1 1/4"	3/8"	3"
RU5125H	RD5125H	1/2"	1 1/4"	1/2"	3"
RU5162H	RD5162H	1/2"	1 5/8"	1/2"	3 1/2"
RU5218H	RD5218H	1/2"	2 3/16"	1/2"	4"
RU6200H	RD6200H	5/8"	2"	5/8"	4"
RU7200H	RD7200H	3/4"	2"	3/4"	4"
RU7325H	RD7325H	3/4"	3 1/4"	3/4"	6"

*For Castle & P-C Pocket Machines.

THREE FLUTE SPIRAL BITS

Up Cut or Down Cut

Solid Carbide - Three Flute



PART # RU5125T

Up Cut Part #	Down Cut Part #	Cutting Diameter	Cutting Length	Shank Diameter	Overall Length
RU4125T	RD4125T	3/8"	1 1/4"	3/8"	3"
RU5125T	RD5125T	1/2"	1 1/4"	1/2"	3"
RU5200T	RD5200T	1/2"	2"	1/2"	4"
RU7200T	RD7200T	3/4"	2"	3/4"	4"

SLOW SPIRAL BITS

Up Cut or Down Cut

Solid Carbide - Three Flute

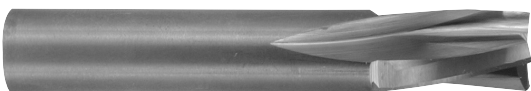

Up Cut Part #	Down Cut Part #	Cutting Diameter	Cutting Length	Shank Diameter	Overall Length
RU4100S	RD4100S	3/8"	1"	3/8"	2 1/2"
RU5100S	RD5100S	1/2"	1"	1/2"	3"
RU5150S	RD5150S	1/2"	1 1/2"	1/2"	3 1/2"

UP/DOWN CUT SPIRAL BITS

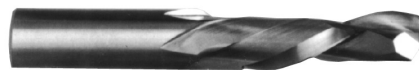

PART # UD5150

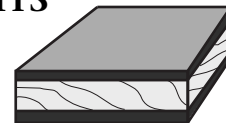

Up/Down Cut (1+1 Compression)

Solid Carbide - Single Flute

Part Number	Cutting Diameter	Cutting Length	Shank Diameter	Overall Length
UD2100	1/4"	1"	1/4"	2 1/2"
UD4125	3/8"	1 1/4"	3/8"	3"
UD5150	1/2"	1 1/2"	1/2"	3 1/2"
UD5160	1/2"	1 5/8"	1/2"	3 1/2"

Up/Down Cut (2+2 Compression)

Solid Carbide - Two Flute

Part Number	Cutting Diameter	Cutting Length	Shank Diameter	Overall Length
UD2102	1/4"	1"	1/4"	2 1/2"
*UD4102M	3/8"	1"	3/8"	2 1/2"
UD4122	3/8"	1 1/4"	3/8"	3"
NEW! *UD4122M	3/8"	1 1/4"	3/8"	3"
UD5122	1/2"	1 1/4"	1/2"	3"
*UD5122M	1/2"	1 1/4"	1/2"	3"
UD5152	1/2"	1 1/2"	1/2"	3 1/2"
UD5162	1/2"	1 5/8"	1/2"	3 1/2"
NEW! *UD5162M	1/2"	1 5/8"	1/2"	3 1/2"
UD5202	1/2"	2"	1/2"	4"
UD6152	5/8"	1 1/2"	5/8"	4"
NEW! UD7152	3/4"	1 1/2"	3/4"	4"
UD7202	3/4"	2"	3/4"	5"

NEW! Up/Down Cut (3+3 Compression)

Solid Carbide - Three Flute

Part Number	Cutting Diameter	Cutting Length	Shank Diameter	Overall Length
*UD4123M	3/8"	1 1/4"	3/8"	3"
UD5123	1/2"	1 1/4"	1/2"	3"
*UD5123M	1/2"	1 1/4"	1/2"	3"
UD5143	1/2"	1 3/8"	1/2"	3 1/2"
UD5163	1/2"	1 5/8"	1/2"	3 1/2"
*UD5163M	1/2"	1 5/8"	1/2"	3 1/2"

*Mortise Style - These bits have a short up-cut end flute. This allows down shear cutting action to the top edge during shallow cuts.

O-FLUTE SPIRAL BITS

Up Cut or Down Cut

Solid Carbide - Slow Spiral

Used primarily for routing plastics



PART # RD2075A

Up Cut Part #	Down Cut Part #	Cutting Diameter	Cutting Length	Shank Diameter	Overall Length
RU2075A	RD2075A	1/4"	3/4"	1/4"	2 1/2"
NEW! RU2076A	RD2076A	1/4"	3/4"	1/4"	2 1/2"



SOLID CARBIDE

O - FLUTE STRAIGHT BITS

Solid Carbide - One Flute

Used primarily for routing plastics



PART #SA2075

Part Number	Cutting Diameter	Cutting Length	Shank Diameter	Overall Length
SA1600	1/8"	3/8"	1/4"	2 1/2"
SA1700	5/32"	1/2"	1/4"	2 1/2"
SA1800	3/16"	1/2"	1/4"	2 1/2"
SA1900	7/32"	5/8"	1/4"	2 1/2"
SA2075	1/4"	3/4"	1/4"	2 1/2"
SA2100	1/4"	1"	1/4"	3 1/2"
SA4100	3/8"	1"	3/8"	3"

LH Rotation available by request.

SOLID CARBIDE STRAIGHT BITS

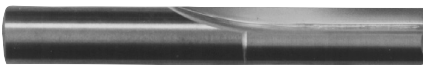

PART # SC19

Part Number	Cutting Diameter	Cutting Length	Shank Diameter	Overall Length
SINGLE FLUTE				
SC062	1/16"	3/16"	1/4"	1 1/2"
SC01	1/16"	5/16"	1/4"	1 1/2"
SC01A	3/32"	5/16"	1/4"	1 1/2"
SC02	1/8"	3/8"	1/4"	1 1/2"
SC03	5/32"	5/8"	1/4"	1 1/2"
SC04	3/16"	1/2"	1/4"	1 1/2"
SC05	7/32"	3/4"	1/4"	2"
SC06	1/4"	3/4"	1/4"	2"
SC07	1/4"	1"	1/4"	2 1/2"
SC08	1/4"	1"	1/4"	3"
SC17	5/16"	1"	5/16"	2 1/2"

DOUBLE FLUTE

SC33	1/8"	1/4"	1/4"	2"
SC09	1/8"	3/8"	1/4"	1 1/2"
SC09A	1/8"	3/8"	1/4"	2"
SC156	5/32"	3/8"	1/4"	1 1/2"
SC10	5/32"	5/8"	1/4"	1 1/2"
SC10A	5/32"	5/8"	1/4"	2"
SC34	3/16"	3/8"	1/4"	2"
SC11	3/16"	1/2"	1/4"	1 1/2"
SC11A	3/16"	1/2"	1/4"	2"
SC12	3/16"	5/8"	1/4"	2"
SC13	7/32"/5.5mm	3/4"	1/4"	2"
SC35	1/4"	1/2"	1/4"	2"
SC14	1/4"	3/4"	1/4"	2"
SC15	1/4"	1"	1/4"	2 1/2"
SC16	1/4"	1"	1/4"	3"
SC18	5/16"	1"	5/16"	2 1/2"
SC19	3/8"	1"	3/8"	2 1/2"
SC19A	3/8"	1 1/4"	3/8"	3"
SC218	7/32"/5.5mm	3/4"	1/2"	2 3/4"
SC235	15/64"/6mm	3/4"	1/2"	2 3/4"
SC20	1/4"	3/4"	1/2"	2 3/4"
SC21	1/4"	1"	1/2"	3"
SC22	5/16"	1"	1/2"	3"
SC23	3/8"	1"	1/2"	3"
SC24	3/8"	1 1/4"	1/2"	3"
SC25	1/2"	1"	1/2"	3"
SC26	1/2"	1 1/4"	1/2"	3"
SC27	1/2"	1 1/2"	1/2"	3 1/2"

STANDARD FLUSH TRIM - 1/4" CUT LENGTH



PART # SC28B

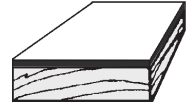

Part Number	Cutting Length	Shank Diameter	Overall Length
SC28B	1/4"	1/4"	1 1/2"
SC28B-BLK	100 Pcs. - Bulk		

FLUSH TRIM - 3/8" CUT LENGTH



PART # SC28



Part Number	Cutting Length	Shank Diameter	Overall Length
SC28	3/8"	1/4"	1 1/2"
SC28-BLK	100 Pcs. - Bulk		

FLUSH TRIM - DOUBLE END

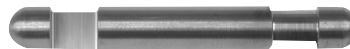

PART # SC28A

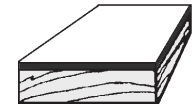

Part Number	Cutting Length	Shank Diameter	Overall Length
SC28A	1/4"	1/4"	2"

DADO TRIM - SMALL PILOT FOR DADO



PART # SC28C

1/8" PILOT



Part Number	Cutting Length	Shank Diameter	Overall Length
SC28C	1/4"	1/4"	1 1/2"
SC28C-BLK	100 Pcs. - Bulk		

7° BEVEL TRIM



PART # SC29



Part Number	Cutting Length	Shank Diameter	Overall Length
SC29	1/4"	1/4"	1 1/2"
SC29-BLK	100 Pcs. - Bulk		

7° BEVEL TRIM - DOUBLE END



PART # SC29A



Part Number	Cutting Length	Shank Diameter	Overall Length
SC29A	1/4"	1/4"	2"

FLUSH & 7° BEVEL TRIM - WITHOUT PILOT

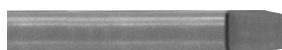

PART # SC30

3/16" x 3/16"

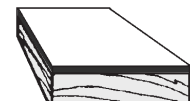

Part Number	Cutting Length	Shank Diameter	Overall Length
SC30	3/8"	1/4"	1 1/2"



SOLID CARBIDE

HOLE & FLUSH TRIM



PART# SC31



Part Number	Cutting Length	Shank Diameter	Overall Length
SC31	3/8"	1/4"	2"

CARVING LINER

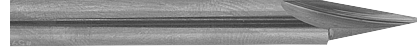

PART# SC50

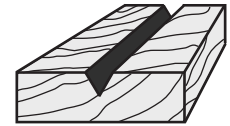

Part Number	Point Length	Shank Diameter	Overall Length
SC50	5/8"	1/4"	2 1/2"

RIP & SLOTTING



PART# SC32



Part Number	Cutting Length	Shank Diameter	Overall Length
SC32	3/8"	1/4"	1 1/2"

SOLID CARBIDE FIBERGLASS BITS



PART #SC90V

Part Number	Cutting Diameter	Cutting Length	Shank Diameter	Overall Length
SC90	1/4"	3/4"	1/4"	2 1/2"
SC90V	1/4"	3/4"	1/4"	2 1/2"
SC91V	1/4"	1"	1/4"	3"



*Note - order SC90 for flat bottom plunge point
SC90V & SC91V are supplied with vee plunge point

FLAT BOTTOM VEINING

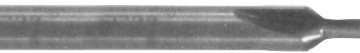

PART# SC33



Part Number	Cutting Diameter	Cutting Length	Overall Length
1/4" SHANK - DOUBLE FLUTE			
SC062	1/16"	3/16"	1 1/2"
SC33	1/8"	1/4"	2"
SC156	5/32"	3/8"	1 1/2"
SC34	3/16"	3/8"	2"
SC35	1/4"	1/2"	2"



SCREW SLOT BITS

Use these **solid carbide** bits with a plunge router to cut slots for #8 screws. Screw slots allow for the seasonal movement of larger wooden parts such as table tops. These bits will also cut up to a 7/16" deep recess for the screw head.

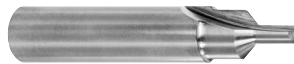

PART #SC100

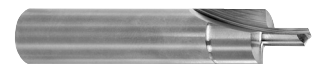

PART #SC102

Part Number	Style	Large Diameter	Cutting Length	Overall Length
1/2" SHANK				
SC100	82° C'sink	7/16"	15/16"	3"
SC102	Flat C'bore	1/2"	15/16"	3"

ROUND BOTTOM VEINING



PART# SC41



Part Number	Radius	Cutting Diameter	Cutting Length	Overall Length
1/4" SHANK - DOUBLE FLUTE				
SC39	1/16"	1/8"	1/4"	2"
SC40	3/32"	3/16"	3/8"	2"
SC41	1/8"	1/4"	1/2"	2"

LH Rotation available by request.



CT STRAIGHTS

CNC ROUTER BITS

Straight Cut - Carbide Tipped

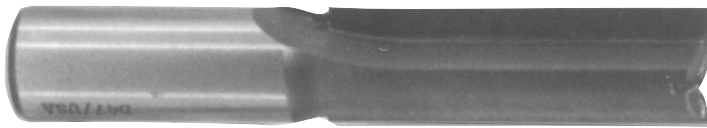

PART # C7525F

CNC Tools are designed to meet the severe applications of CNC routing. These tools offer superior performance over standard straight flute bits at the high feed rates commonly found on CNC routers. They also provide an economical alternative to the more expensive spiral bits. For the ultimate in CNC routing, choose from Whiteside's wide selection of Solid Carbide Spiral Bits listed on pages 2 and 3.

**** Use on CNC Routers only.**

Part Number	Cutting Diameter	Cutting Length	Overall Length
1/2" SHANK • SINGLE FLUTE			
C1052	1/2"	1 1/4"	2 7/8"
C1055	1/2"	2"	4 1/8"
1/2" SHANK • DOUBLE FLUTE			
C1067	1/2"	1 1/4"	2 7/8"
C1069	1/2"	1 1/2"	3 1/8"
C1072	1/2"	2"	4 1/8"
5/8" SHANK • DOUBLE FLUTE			
C6310	5/8"	1 1/4"	3"
C6320	5/8"	2"	4"
3/4" SHANK • DOUBLE FLUTE			
C7512	3/4"	1 1/4"	3"
C7515	3/4"	1 1/2"	3 1/4"
C7520	3/4"	2"	4"
C7520F	3/4"	2"	4"
C7520V	3/4"	2"	4"
C7525	3/4"	2 1/2"	4 1/2"
C7525F	3/4"	2 1/2"	4 1/2"
C8820V	7/8"	2"	4"
C1108	1"	1 1/2"	3 1/4"
C1109	1"	2"	4 1/4"

F - Supplied with Carbide Flat Bottom Boring Point
V - Supplied with Carbide Vee Bottom Boring Point

LEFT HAND - STRAIGHT CUT



PART # 1066LH



Part Number	Cutting Diameter	Cutting Length	Overall Length
1/4" SHANK • DOUBLE FLUTE			
1014LH	1/4"	1"	2 1/2"
1/2" SHANK • DOUBLE FLUTE			
1062LH	3/8"	1"	2 5/8"
1066LH	1/2"	1"	2 5/8"
1069LH	1/2"	1 1/2"	3 1/8"
1072LH	1/2"	2"	4 1/8"
1085LH	3/4"	1 1/4"	3"
3/4" SHANK • DOUBLE FLUTE			
1105LH	3/4"	2"	5"
* 1126LH	3/4"	2 1/2"	5"
* 1128LH	3/4"	2 1/2"	5 1/2"

* Recommended for "Topmaster" machines.

NOTE: Left Hand Spiral Bits also available, See pg. 2

1/4" SHANK STRAIGHT BITS



PART # 1025



Part Number	Cutting Diameter	Cutting Length	Overall Length	Special Use
1/4" SHANK • SINGLE FLUTE				
<i>For smaller sizes see solid carbide straight bits on page 4.</i>				
1004	1/4"	3/4"	2 1/4"	
1005	1/4"	1"	2 1/2"	
1007	1/4"	1"	3 1/8"	
NEW! 1007A	1/4"	1"	3 1/4"	Air Router
1008	9/32"	3/4"	2 1/4"	

Part Number	Cutting Diameter	Cutting Length	Overall Length	Special Use
1/4" SHANK • DOUBLE FLUTE				
<i>For smaller sizes see solid carbide straight bits on page 4.</i>				
1012	1/4"	1/2"	2"	
1013	1/4"	3/4"	2 1/4"	Incra™
1014	1/4"	1"	2 1/2"	
1016	1/4"	1"	3"	
1016-01	1/4"	1"	3 1/4"	Air Router
1018	9/32"	1"	3"	
1019	5/16"	1"	2 1/2"	Omnijig® #43300
1020	5/16"	1"	2 3/4"	Leigh #140
1020x8	5/16"	1"	2 3/4"	Leigh #140-8mm shank
1021	3/8"	3/4"	2 1/4"	
1022	3/8"	1"	2 1/2"	Incra™
1023	3/8"	1 1/4"	2 3/4"	
NEW! 1023A	13/32"	1"	2 1/2"	
1024	7/16"	1"	2 1/2"	
1024A	31/64"	3/4"	2 1/4"	Undersize Plywood Dado
1025	1/2"	3/4"	2 1/4"	
1026	1/2"	1"	2 1/2"	Omnijig® #43318
1027	9/16"	3/4"	2 1/4"	
1027A	19/32"	3/4"	2 1/4"	Undersize Plywood Dado
1028	5/8"	3/4"	2 1/8"	
1029	11/16"	3/4"	2 1/8"	
1029A	23/32"	3/4"	2 1/8"	Undersize Plywood Dado
1030	3/4"	3/4"	2 1/8"	
1031	3/4"	1"	2 5/8"	
1033	1"	3/4"	2 1/8"	
1303	1 1/4"	1/2"	2 1/8"	Mortising

3/8" SHANK STRAIGHT BITS



PART # 1039

Part Number	Cutting Diameter	Cutting Length	Overall Length	Special Use
3/8" SHANK • SINGLE FLUTE				
1035	3/8"	1"	2 5/8"	
1036	3/8"	1 1/4"	2 7/8"	
3/8" SHANK • DOUBLE FLUTE				
1039	3/8"	1"	2 5/8"	
1040	3/8"	1 1/4"	2 7/8"	
1041	3/8"	1 1/4"	3 5/8"	Air Router
1043	1/2"	1"	2 1/2"	
1045	7/8"	1"	2 1/2"	



CT STRAIGHTS

1/2" SHANK STRAIGHT BITS

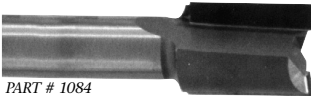

PART # 1084



Part Number	Cutting Diameter	Cutting Length	Overall Length	Special Use
1/2" SHANK • SINGLE FLUTE				
1049	3/8"	1"	2 5/8"	
1050	3/8"	1 1/4"	2 7/8"	
1051	1/2"	3/4"	2 3/8"	Midwest Machine
1052	1/2"	1 1/4"	2 7/8"	
1054	1/2"	1 1/2"	3 1/8"	
1055	1/2"	2"	4 1/8"	
1055A	1/2"	2 1/2"	4 3/8"	
1/2" SHANK • DOUBLE FLUTE				
1058	1/4"	3/4"	2 3/8"	Incra™
1059	9/32"	3/4"	2 3/8"	
1060	5/16"	1"	2 5/8"	
1061	3/8"	3/4"	2 3/8"	
1062	3/8"	1"	2 5/8"	Incra™
1063	3/8"	1 1/4"	2 7/8"	
1064	13/32"	3/4"	2 1/2"	
1065	7/16"	1 1/4"	2 7/8"	
1065L	7/16"	1 1/4"	3 1/4"	Leigh #150
1065A	31/64"	1"	2 5/8"	Undersize Plywood Dado
1066	1/2"	1"	2 5/8"	
1067	1/2"	1 1/4"	2 7/8"	Leigh #160
1067F	1/2"	1 1/4"	2 7/8"	Carbide Boring Point
1069	1/2"	1 1/2"	3 1/8"	
1069DS	1/2"	1 1/2"	3 1/8"	Down Shear
1070	1/2"	1 1/2"	4 1/8"	
1071	1/2"	2"	3 1/2"	
1072	1/2"	2"	4 1/8"	
1073	1/2"	2 1/2"	4 3/8"	
1073-01	1/2"	2 1/2"	5 1/2"	
1074	17/32"	1 1/4"	2 7/8"	
1075	9/16"	1 1/4"	3"	
1075A	19/32"	3/4"	2 1/4"	Undersize Plywood Dado
1076	5/8"	1"	2 1/2"	
1076F	5/8"	1"	2 1/2"	Carbide Boring Point
1077	5/8"	1 1/4"	3"	
1078	5/8"	1 1/2"	3"	
1079	5/8"	2"	4"	
1080	21/32"	1 1/4"	3"	
1082	11/16"	1"	2 1/2"	
1083	11/16"	1 1/4"	3"	
1083A	23/32"	1"	2 1/2"	Undersize Plywood Dado
1302A	3/4"	5/8"	2 1/4"	Mortising
1084	3/4"	1"	2 3/4"	
1085	3/4"	1 1/4"	3"	
1085F	3/4"	1 1/4"	3"	Carbide Boring Point
1086	3/4"	1 1/2"	3 1/4"	
1087	3/4"	2"	3 5/8"	
1088	25/32"	1 1/4"	3"	
1090	13/16"	1 1/4"	3"	
1091	7/8"	1 1/4"	3"	
NEW! 1092	15/16"	1 1/4"	3"	
1093	1"	1 1/4"	3"	
1093F	1"	1 1/4"	3"	Carbide Boring Point
1094	1"	1 1/2"	3"	
1095	1"	2"	3 3/4"	
1096	1 1/8"	1 1/2"	3"	
1304	1 1/4"	1/2"	2 1/8"	Mortising
1097	1 1/4"	1 1/2"	3"	
1098	1 3/8"	1 1/4"	3"	
1099	1 1/2"	1 1/4"	3"	
1100	1 3/4"	1 1/4"	3"	
1101	2"	1 1/4"	3"	

STRAIGHT CUT CABINET DADO BITS For Undersized Plywood



PART # 1024A

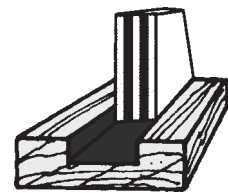

Part Number	Cutting Diameter	Plywood Size	Cutting Length	Overall Length
1/4" SHANK • DOUBLE FLUTE				
SC13	7/32"	1/4"/5.5mm	3/4"	2"
1024A	31/64"	1/2"	3/4"	2 1/4"
1027A	19/32"	5/8"	3/4"	2 1/4"
1029A	23/32"	3/4"	3/4"	2 1/8"
1/2" SHANK • DOUBLE FLUTE				
SC218	7/32"	1/4"/5.5mm	3/4"	2 3/4"
SC235	15/64"	15/64"/6mm	3/4"	2 3/4"
1065A	31/64"	1/2"	1"	2 5/8"
1075A	19/32"	5/8"	3/4"	2 1/4"
1083A	23/32"	3/4"	1"	2 1/2"

SC - Solid Carbide

TEMPLATE BITS Ball Bearing Guide

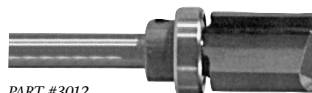

PART #3012



Part Number	Cutting Diameter	Cutting Length	Overall Length	Bearing Number
1/4" SHANK				
* 3000A	1/2"	1/8"	1 3/4"	B9
* 3000	1/2"	1/4"	1 7/8"	B9
NEW! 3001	1/2"	1/2"	2"	B9
3002	1/2"	3/4"	2 1/4"	B9
3004	1/2"	1"	2 1/2"	B9
* 3006	5/8"	1/4"	1 3/4"	B6
K41	5/8"	1/2"	2 1/4"	B6
K43	5/8"	3/4"	2 1/2"	B6
3008	5/8"	1"	2 1/2"	B6
* 3010	3/4"	1/4"	1 3/4"	B4
3012	3/4"	3/4"	2 3/8"	B4
3014	3/4"	1"	2 5/8"	B4
3/8" SHANK				
3015	7/8"	1"	2 5/8"	B12
1/2" SHANK				
3016	1 1/8"	1"	3"	B11
3018	1 1/8"	1 1/2"	3 1/2"	B11
3019	1 1/8"	2"	4"	B11
*** 3020	3/4"	1"	2 3/4"	***B19
*** 3021	3/4"	1 1/4"	3"	***B19
*** 3022	3/4"	1 1/2"	3 1/4"	***B19
NEW! 3022A	7/8"	1 1/2"	3 1/2"	B13
*** 3023	3/4"	2"	3 5/8"	***B19

* Dado Clean out bits. Use to Square the bottom of dado cuts made on a table saw.

*** Whiteside recommends using bits over 3/4" diameter in 1/2" shank whenever possible due to the fragile nature of the B19 bearing.



STAGGERTOOTH · MORTISE

STAGGERTOOTH BITS

Straight Flute



PART # 1202



Part Number	Cutting Diameter	Cutting Length	Overall Length
1/4" SHANK			
1200	1/4"	1 1/4"	3 1/2"
1/2" SHANK			
1201	3/8"	1 1/2"	3 1/8"
1202	1/2"	1 1/2"	3 1/8"
1203	1/2"	2 1/8"	4"
1205	1/2"	2 5/8"	5 1/2"

MORTISE BITS



PART # 1300



Part Number	Cutting Diameter	Cutting Length	Overall Length
1/4" SHANK			
1300	1/2"	3/4"	2 1/8"
1301	5/8"	3/4"	2 1/8"
1302	3/4"	3/4"	2 1/8"
1303	1 1/4"	1/2"	2 1/8"
1/2" SHANK			
1302A	3/4"	5/8"	2 1/4"
1304	1 1/4"	1/2"	2 1/8"

If you need a square corner on your mortise, use Whiteside's Square Corner Chisel (see page 34).

UP/DOWN STAGGERTOOTH BITS

Opposite Shear (Compression)



PART # 1260

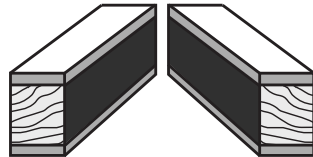

Part Number	Cutting Diameter	Cutting Length	Overall Length
1/2" SHANK			
1250	1/2"	1 1/2"	3 1/2"
1252	1/2"	2"	4"
5/8" SHANK			
1260	3/4"	2"	4"
3/4" SHANK			
1270	3/4"	2"	4"

SCREW TYPE HELIX MORTISE

With Downshear - Cutter Only

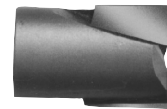

PART # 13-750



Part Number	Cutting Diameter		Cutting Length	Overall Length
	Fractional	Decimal		
13-500	1/2"	.500	5/8"	7/8"
13-515	33/64"	.515	5/8"	7/8"
13-531	17/32"	.531	5/8"	7/8"
13-562	9/16"	.562	5/8"	7/8"
13-625	5/8"	.625	5/8"	7/8"
13-640	41/64"	.640	5/8"	7/8"
13-656	21/32"	.656	5/8"	7/8"
13-687	11/16"	.687	5/8"	7/8"
13-719	23/32"	.719	5/8"	7/8"
13-750	3/4"	.750	5/8"	7/8"
13-765	49/64"	.765	5/8"	7/8"
13-781	25/32"	.781	5/8"	7/8"
13-812	13/16"	.812	5/8"	7/8"
13-875	7/8"	.875	5/8"	7/8"
13-937	15/16"	.937	5/8"	7/8"
13-1000	1"	1.000	1/2"	1/2"
13-1125	1 1/8"	1.125	1/2"	1/2"
13-1250	1 1/4"	1.250	1/2"	1/2"
*13-1250A	1 1/4"	1.250	1/2"	1/2"

*13-1250A supplied with 5/16"-24 threads

All others supplied with 1/4"-28 threads

Special Cutting Diameters Available by Special Order.

**MADE
WITH
PRIDE
IN THE
U.S.A.**

HELIX MORTISE ARBORS

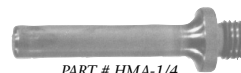

PART # HMA-1/4

Part Number	Shank Diameter	Thread	Overall Length
HMA-1/4	1/4"	1/4"-28	1 3/4"
HMA-1/2	1/2"	1/4"-28	1 3/4"
* HMA-1/4A	1/4"	5/16"-24	1 3/4"
* HMA-1/2A	1/2"	5/16"-24	1 3/4"

* Fits #13-1250A only



ROUND NOSE • HALF ROUND

BOWL & TRAY BITS



PART # 1374

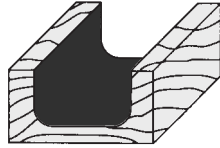

Part Number	Radius	Cutting Diameter	Cutting Length	Overall Length
1/4" SHANK				
1370	1/8"	7/16"	5/16"	2 1/8"
1372	1/4"	3/4"	5/8"	2 3/8"
* 1372B	1/4"	3/4"	5/8"	2 3/8"
1/2" SHANK				
1374	1/4"	3/4"	5/8"	2 3/8"
1376	1/4"	1 1/4"	1/2"	2 1/4"
* 1376B	1/4"	1 1/4"	1/2"	2 1/4"

*Supplied with Bearing on Shank for Pattern Template Routing.

ROUND NOSE (CORE BOX)



PART #1408



Part Number	Radius	Cutting Diameter	Cutting Length	Overall Length
1/4" SHANK				
SC SC39	1/16"	1/8"	1/4"	2"
SC SC40	3/32"	3/16"	3/8"	2"
SC SC41	1/8"	1/4"	1/2"	2"
1403	3/16"	3/8"	1/2"	2"
1404	1/4"	1/2"	5/8"	2 1/4"
1405	5/16"	5/8"	3/8"	2"
1406	3/8"	3/4"	7/16"	2"
1/2" SHANK				
1407	3/16"	3/8"	1"	2 5/8"
1408	1/4"	1/2"	1 1/4"	2 7/8"
1410	5/16"	5/8"	1 1/4"	2 7/8"
1411	3/8"	3/4"	1 1/4"	2 7/8"
1412	7/16"	7/8"	1 1/4"	2 7/8"
1413	1/2"	1"	1 1/4"	2 7/8"
1414	5/8"	1 1/4"	1 1/4"	3"
1415	3/4"	1 1/2"	1 1/4"	3"
1416	7/8"	1 3/4"	1 1/4"	3"
1417	1"	2"	1 1/4"	3"
3/4" SHANK				
1420	3/8"	3/4"	2"	4"

SC - Solid Carbide

ROUND NOSE With Bearing Guide

The addition of a shank mounted bearing extends the use of our round nose bits in lettering, veining, or decorative cuts when following a template.

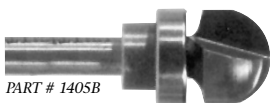

PART # 1405B

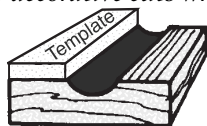

Part Number	Radius	Cutting Diameter	Cutting Length	Bearing Number
1/4" SHANK				
1404B	1/4"	1/2"	5/8"	B9
1405B	5/16"	5/8"	3/8"	B6
1406B	3/8"	3/4"	7/16"	B4

HALF ROUND (BULL NOSE)

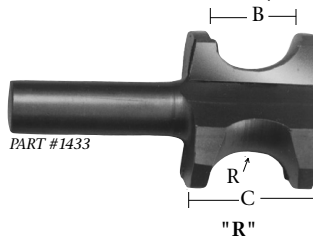

PART #1433



Part Number	Radius	"B" Opening of Cutter	"C" Cutting Length	Large Diameter
1/4" SHANK				
1425	3/32"	3/16"	1/2"	3/4"
1426	1/8"	1/4"	9/16"	7/8"
1427	3/16"	3/8"	7/8"	1"
1428	1/4"	1/2"	1"	1 1/8"
1/2" SHANK				
1429	3/32"	3/16"	1/2"	3/4"
1430	1/8"	1/4"	9/16"	7/8"
1431	3/16"	3/8"	7/8"	1"
1432	1/4"	1/2"	1"	1 1/8"
1432A	5/16"	5/8"	1"	1 1/4"
1433	3/8"	3/4"	1 1/4"	1 5/8"
1433A	7/16"	7/8"	1 1/2"	1 7/8"
1434	1/2"	1"	1 1/2"	1 15/16"
1434A	9/16"	1 1/8"	1 1/2"	1 15/16"
1435	5/8"	1 1/4"	1 3/4"	2 3/16"
1436	3/4"	1 1/2"	1 7/8"	2 7/16"

Note- Large Diameter minus "B" opening equals small diameter.

PLUNGE CUT HAND GRIP

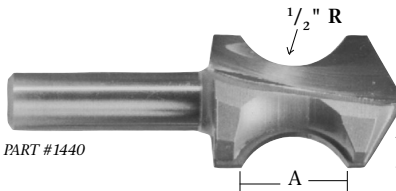

PART #1440

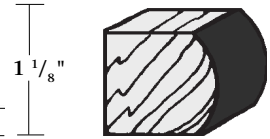

Part Number	"A" Bead Opening	"B" Bead Depth	Cutting Length	Overall Length
1/2" SHANK				
1440	7/8"	1/4"	1 3/8"	3 1/2"

Use with B11 Bearing and LC-1/2 lock collar on shank for guide template routing.

OVAL EDGE (HALF BULL NOSE)

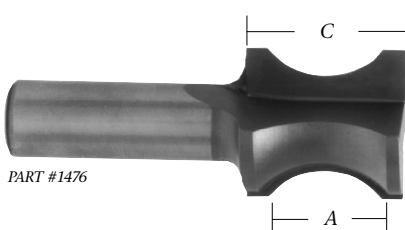

PART #1476

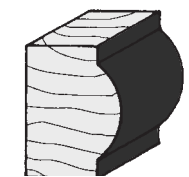

ACTUAL SIZE - 1474

Part Number	"A" Bead Opening	"B" Bead Depth	"C" Cutting Length	Large Diameter
1/2" SHANK				
NEW! 1470	7/8"	5/32"	1 1/4"	13/16"
1474	1/2"	1/8"	1"	3/4"
1476	3/4"	3/16"	1 1/4"	1"
1478	1"	3/16"	1 1/4"	1"
1480	1 1/2"	1/4"	1 3/4"	1 1/4"

WM V GROOVE • PANEL • COVE

V GROOVE - 90° INCLUDED ANGLE

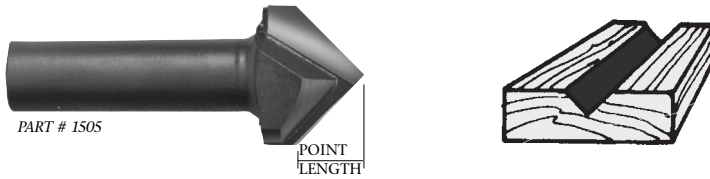

Part Number	Cutting Diameter	Point Length	Overall Length
1/4" SHANK			
SC 1500	1/4"	1/8"	1 1/2"
1501	3/8"	3/16"	1 7/8"
1502	1/2"	1/4"	1 7/8"
1/2" SHANK			
1503	1/2"	1/4"	2"
1504	3/4"	3/8"	2 1/4"
1506	1"	1/2"	2 1/4"
1508	1 1/2"	3/4"	2 5/8"

SC - Solid Carbide

Not for miter folding.

V GROOVE - 60° INCLUDED ANGLE

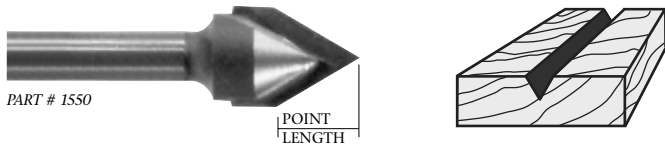

Part Number	Cutting Diameter	Point Length	Overall Length
1/4" SHANK			
SC 1540	1/4"	7/32"	1 1/2"
* SC 1541	1/4"	7/32"	2"
1550	1/2"	7/16"	2"
1/2" SHANK			
1560	1/2"	7/16"	2 1/4"

SC - Solid Carbide

* #1541 features three flutes for improved veining

POINT CUTTING ROUNDOVER Decorative Trimming & Lettering

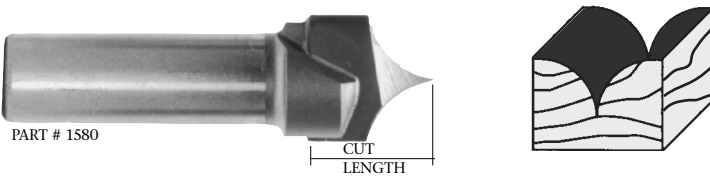

Part Number	Radius	Cutting Diameter	Cutting Length	Overall Length
1/4" SHANK				
1570	3/16"	3/8"	3/8"	2"
1572	1/4"	1/2"	1/2"	2"
1574	3/8"	3/4"	5/8"	2"
1/2" SHANK				
1580	3/8"	3/4"	5/8"	2 1/4"

Point Cutting Roundovers are not guaranteed against breakage.

PANEL BITS - PILOT PLUNGE POINT



Part Number	Cutting Diameter	Cutting Length	Shank Diameter	Overall Length
SINGLE FLUTE				
1700	1/4"	3/4"	1/4"	2 5/8"
1701	3/8"	1"	3/8"	3 3/8"
1702	1/2"	1 1/4"	1/2"	4"
NEW! 1702A	1/2"	1 1/4"	1/2"	3 5/8"
DOUBLE FLUTE				
1704	3/8"	1"	1/4"	3 1/4"
1705	3/8"	1"	3/8"	3"
1706	1/2"	1 1/4"	1/2"	4"

STAGGERTOOTH PANEL BIT With Center Pilot

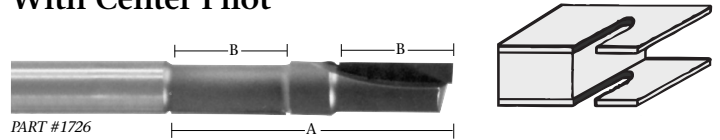

Part Number	Cutting Diameter	"A" Cutting Length	"B" Flute Length	Overall Length
1/2" SHANK				
1726	1/2"	2 3/4"	1 1/8"	4 1/4"

COVE BITS

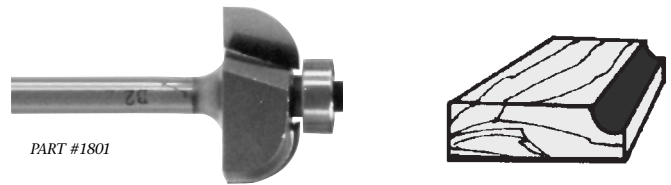

Part Number	Radius	Large Diameter	Cutting Length	Bearing Number
1/4" SHANK				
1800A	3/16"	7/8"	1/2"	B3
1800	1/4"	1"	1/2"	B3
1801	3/8"	1 1/4"	1/2"	B3
1802	1/2"	1 1/2"	5/8"	B3
1/2" SHANK				
1803	1/4"	1"	1/2"	B3
1804	3/8"	1 1/4"	1/2"	B3
1805	1/2"	1 1/2"	5/8"	B3
1806	5/8"	1 3/4"	3/4"	B3
1807	3/4"	2"	7/8"	B3
1810	1"	2 1/2"	1"	B3

Bearing Number: B3



RABBETING

RABBET BITS

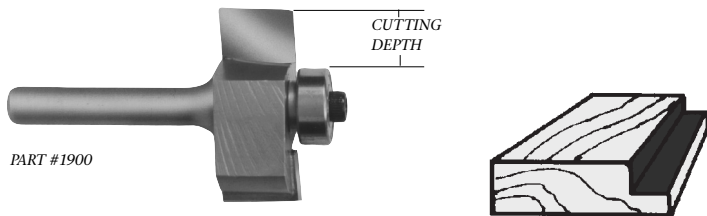

Part Number	Large Diameter	Cutting Length	Cutting Depth	Bearing Number
1/4" SHANK				
1900	1 1/4"	1/2"	3/8"	B3
1951	1 3/8"	1/2"	1/2"	B2
1/2" SHANK				
1901	1 1/4"	1/2"	3/8"	B3
1954	1 3/8"	1/2"	1/2"	B2
1959	1 7/8"	1"	3/4"	B2

SLOTING & RABBETING

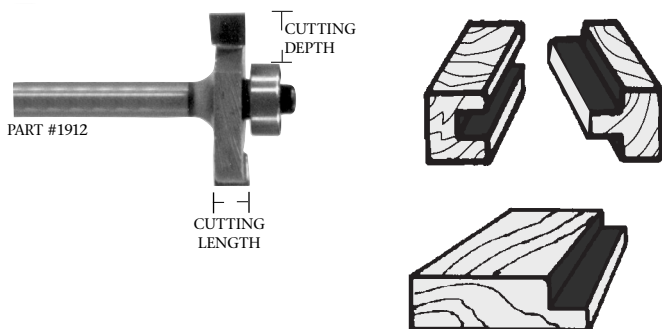

Part Number	Large Diameter	Cutting Length	Cutting Depth	Overall Length
1/4" SHANK				
1904	1 1/4"	1/8"	3/8"	2"
*1908	1 1/2"	5/32"	1/2"	1 3/4"
1912	1 1/4"	1/4"	3/8"	2"
1916	1 1/4"	3/8"	3/8"	2"
1920	1 1/2"	1/2"	1/2"	2"
1/2" SHANK				
1906	1 1/4"	1/8"	3/8"	2"
*1910	1 1/2"	5/32"	1/2"	2"
1914	1 1/4"	1/4"	3/8"	2"
1918	1 1/4"	3/8"	3/8"	2 1/8"
1922	1 1/2"	1/2"	1/2"	2 1/4"
1924	1 1/4"	3/4"	3/8"	2 1/2"

B3 Bearing supplied.

*Proper Size for Biscuit Joining

BB501 - Bearing Kit with Wrench (see pg. 35). Increase the versatility of your Rabbeting Bits by simply changing the bearing size to vary your cutting depth. This set allows 1/4", 5/16", 3/8", & 7/16" cutting depth on all 1 1/4" bits or 3/8", 7/16", 1/2", & 9/16" cutting depth on all 1 1/2" bits.

BISCUIT JOINING KIT



This kit contains our 5/32" Rabbeting Bit with 1/2" B3 bearing for cutting slots to fit #20 Biscuits. Also includes alternate bearings B14 and B15 to cut slots for #0 and #10 Biscuits. Hex Wrench included.

Part Number	Description
1940	1/4" shank kit
1945	1/2" shank kit

MULTI RABBET SET



Change your Rabbet depth by changing the bearing! Set includes all eight bearings to make each of the cuts shown. Hex Wrench included.

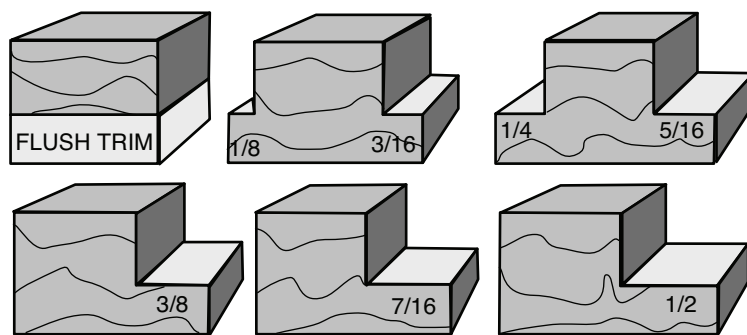

Set Number	Large Diameter	Cutting Length	Description
1952	1 3/8"	1/2"	1/4" Shank Set
1955	1 3/8"	1/2"	1/2" Shank Set

Sets are organized and protected in 4" x 4" x 3" Box.

DEEP MULTI RABBET SET

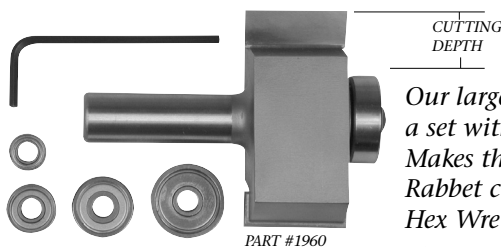

Our largest Rabbet Bit in a set with five bearings. Makes those extra deep Rabbet cuts as shown. Hex Wrench included.

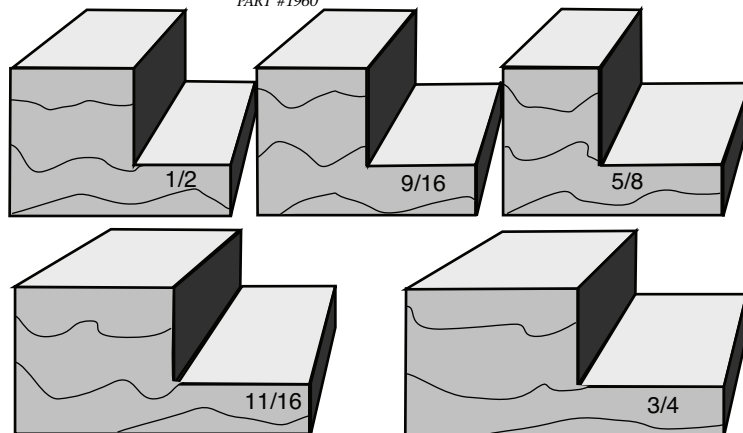

Set Number	Large Diameter	Cutting Length	Description
1960	1 7/8"	1"	1/2" Shank Set

Sets are organized and protected in 4" x 4" x 3" Box.



ROUND OVER

ROUND OVER BITS

Small Pilot



PART # 1982

GREAT FOR
TIGHT
PLACES

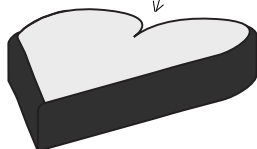

Extra Small Brass Pilot (5/32" dia.) allows these bits to roundover edges on finely detailed workpieces with intricate contours, tight confines, and narrow openings. These bits give professional results without all the tedious hand sanding. Carbide cutting edges far outlast comparable high speed steel bits.

Part Number	Radius	Large Diameter	Cutting Length	Overall Length
1/4" SHANK				
1978	1/16"	3/8"	7/16"	2"
1980	1/8"	3/8"	7/16"	2"
1982	1/4"	5/8"	1/2"	2 1/8"
1984	3/8"	7/8"	5/8"	2 1/4"

MULTI-BEADING SETS

For extra deep beading



PART # 2042

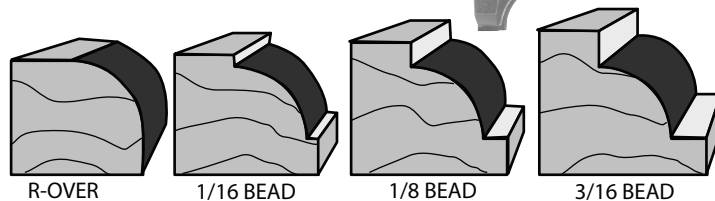

Roundover and More! Conventional Beading only cuts a shallow 1/16" bead. Expand your capabilities with these versatile sets. Deeper beads create a more pronounced edge on larger pieces. Includes all four bearings and Hex Key Wrench.

Part Number	Radius	Large Diameter	Cutting Length	Overall Length
1/2" SHANK				
2040B	1/4"	1 1/4"	1/2"	2 3/8"
2042B	3/8"	1 1/2"	5/8"	2 1/2"
2044B	1/2"	1 3/4"	3/4"	2 5/8"

ROUND OVER & BEADING

Ball Bearing Guide

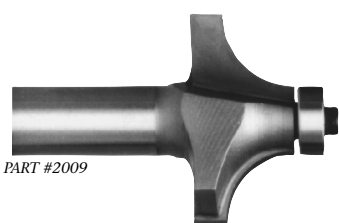

PART # 2009

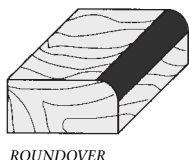

ROUND OVER

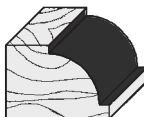

BEADING

Round-Over Part Number	Beading Part Number	Radius	Large Diameter	Cutting Length
1/4" SHANK				
2000A	2100A	1/16"	5/8"	1/2"
2000B		3/32"	11/16"	1/2"
2000C	2100C	1/8"	3/4"	1/2"
2000D	2100D	5/32"	13/16"	1/2"
2000	2100	3/16"	7/8"	1/2"
2001	2101	1/4"	1"	1/2"
2002	2102	5/16"	1 1/8"	1/2"
2003	2103	3/8"	1 1/4"	5/8"
2004	2104	1/2"	1 1/2"	3/4"
1/2" SHANK				
2005C	2105C	1/8"	3/4"	1/2"
2005	2105	3/16"	7/8"	1/2"
2006	2106	1/4"	1"	1/2"
2007	2107	5/16"	1 1/8"	1/2"
2008	2108	3/8"	1 1/4"	5/8"
2008A		7/16"	1 3/8"	5/8"
2009	2109	1/2"	1 1/2"	3/4"
2009A		5/8"	1 3/4"	1"
2009B		9/16"	1 5/8"	3/4"
210	2110	3/4"	2"	1"
2011		7/8"	2 1/4"	1 1/8"
2012		1"	2 1/2"	1 5/16"
2013		1 1/8"	3"	1 1/2"
2014		1 1/4"	3 1/4"	1 3/4"
2015		1 3/8"	3 1/2"	1 3/4"
2016		1 1/2"	3 3/4"	1 7/8"

PLUNGE ROUND OVER

With Plunge Point

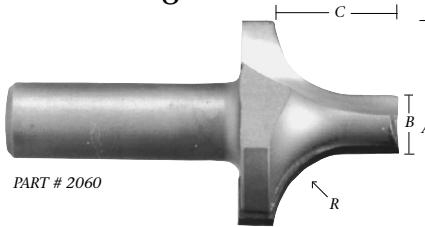

PART # 2060



Part Number	"R" Radius	"A" Large Diameter	"B" Small Diameter	"C" Pattern Length	Overall Length
1/4" SHANK					
2050	1/8"	3/8"	1/8"	1/4"	1 3/4"
2051	3/16"	5/8"	1/4"	1/8"	1 3/4"
2052	1/4"	3/4"	1/4"	3/8"	1 7/8"
1/2" SHANK					
2055	1/4"	3/4"	1/4"	1/4"	2"
2056	1/4"	3/4"	1/4"	3/8"	2"
2057	3/8"	1"	1/4"	5/16"	2 1/8"
2058	3/8"	1"	1/4"	9/16"	2 1/4"
2060	1/2"	1 3/8"	3/8"	3/4"	2 1/2"
2062	9/16"	1 5/8"	1/2"	1"	2 3/4"
2064	5/8"	1 3/4"	1/2"	1 1/16"	3"
2066	3/4"	2"	1/2"	1 1/8"	3"

ROUND OVER & EDGE TRIM (Long Nose)

Part Number	"R" Radius	"A" Large Diameter	"B" Small Diameter	"C" Pattern Length	Overall Length
1/2" SHANK					
*2068	3/16"	1"	1/2"	13/16"	2 5/8"
**2070	3/16"	1"	1/2"	1 5/16"	3 1/8"
*2072	1/4"	1 1/8"	1/2"	13/16"	2 5/8"
**2074	1/4"	1 1/8"	1/2"	1 5/16"	3 1/4"
*2076	3/8"	1 3/8"	1/2"	13/16"	2 3/4"
**2078	3/8"	1 3/8"	1/2"	1 5/16"	3 1/4"

* Edge Trim for 3/4" stock
 ** Edge Trim for 1 1/4" stock

Bearing: Use B3 for Rounding Over
 Use B2 for Beading
 Use B4 for 2013 thru 2016



ROMAN OGEE • CHAMFER

DOUBLE ROUND OVER with Adjustable Cutting Length

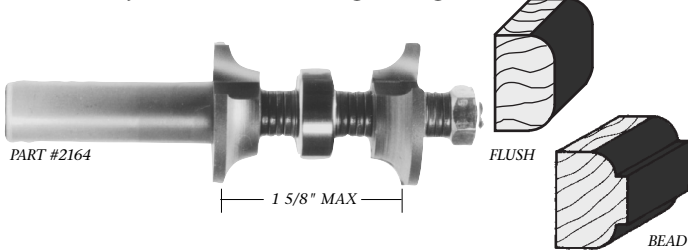

Part Number	Radius	Large Diameter	Overall Length
1/2" SHANK			
2160	1/8"	1 1/8"	3 3/4"
2162	3/16"	1 1/4"	3 3/4"
2164	1/4"	1 3/8"	3 3/4"

Assemblies Sold with B5 Bearing for flush round over
Use B20 Bearing for 1/16" Bead • Use B27 Bearing for 1/8" Bead
Replacement Cutter Heads: Add RH to Part Number for cutter next to shank,
Add LH to Part Number for end cutter.
Example: 2160LH

45° CHAMFER

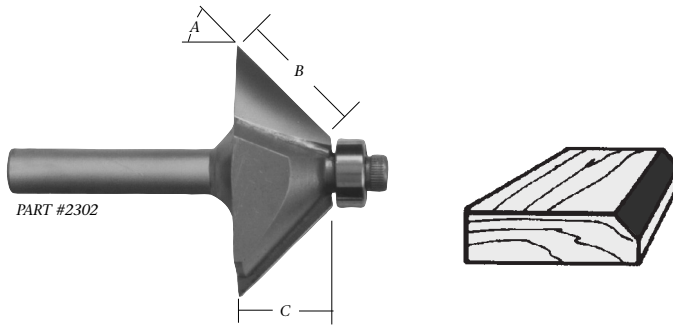

Part Number	"A" Degree of Angle	"B" Cutting Length	"C" Cutting Height	Overall Length
1/4" SHANK				
*2292	45°	7/16"	5/16"	1 7/8"
2302	45°	5/8"	7/16"	2"
1/2" SHANK				
2305	45°	5/8"	7/16"	2 1/4"
2306	45°	1 1/16"	3/4"	2 1/2"
2310	45°	1 1/2"	1 1/16"	3"

Bearing Number: B3 (Use B2 on #2292)
* 2292 has 1" large diameter for use in trim routers.

ROMAN OGEE



Part Number	Radius	Large Diameter	Cutting Length	Overall Length
1/4" SHANK				
2200	5/32"	1 1/8"	9/16"	2"
2201	1/4"	1 1/2"	11/16"	2 1/4"
1/2" SHANK				
2202	5/32"	1 1/8"	9/16"	2 1/4"
2203	1/4"	1 1/2"	11/16"	2 3/8"
2210	3/8"	2"	1"	2 3/4"

Bearing Number: B3

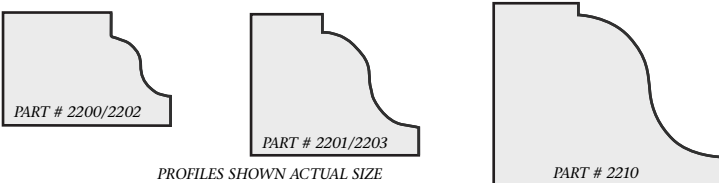

EDGE BEVEL

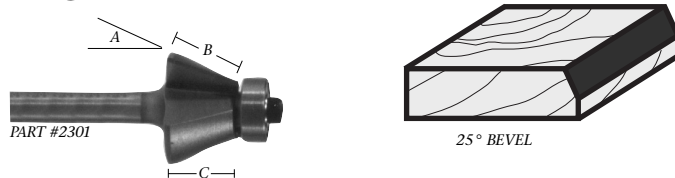

Part Number	"A" Degree of Angle	"B" Cutting Length	"C" Cutting Height	Overall Length
1/4" SHANK				
* 2298	7°	3/8"	3/8"	2 1/8"
2300	15°	1/2"	1/2"	2"
* 2300A	15°	1/4"	1/4"	2"
2301	25°	9/16"	1/2"	2"
¹ 2308	30°	7/8"	3/4"	2 3/4"
1/2" SHANK				
³ 2325	15°	1"	15/16"	2 3/4"
² 2307	22 1/2°	15/16"	7/8"	2 3/4"
¹ 2309	30°	7/8"	3/4"	2 3/4"

Bearing Number: B3
* Used on Laminate Trim
¹ Used for six sided boxes
² Used for eight sided boxes
³ Used for twelve sided boxes

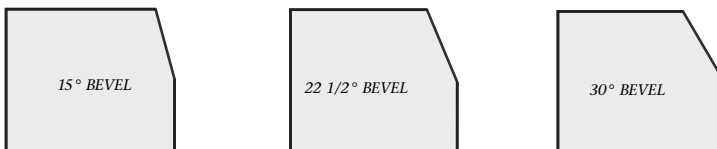



FLUSH TRIM

FLUSH TRIM-TWO FLUTE



Part Number	Cutting Diameter	Cutting Length	Overall Length	Bearing Number
1/4" SHANK				
2400	3/8"	1"	2 5/8"	B1
2401	3/8"	1/2"	2 1/8"	B1
2402	1/2"	1"	2 5/8"	B3
2403	1/2"	1/2"	2 1/8"	B3
1/2" SHANK				
2404A	3/8"	1"	3 1/8"	B1
2405	1/2"	1"	3 1/4"	B3
2406	1/2"	1/2"	2 3/4"	B3
2407	1/2"	1 1/2"	3 5/8"	B3
2408	1/2"	2"	4"	B3
2410	3/4"	1 1/4"	3 1/4"	B4
NEW! 2415	7/8"	1 1/2"	3 1/2"	B21
1/2" SHANK - DOUBLE BEARING				
2457	1/2"	1 1/2"	3 7/8"	Two B3
2458	1/2"	2"	4 1/4"	Two B3

FLUSH TRIM - THREE FLUTE

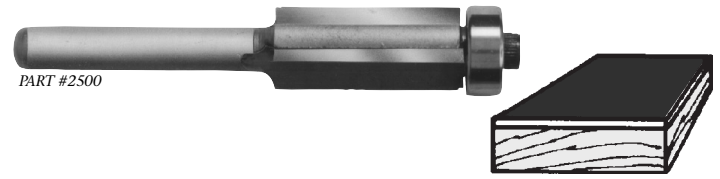

Part Number	Cutting Diameter	Cutting Length	Overall Length	Bearing Number
1/4" SHANK				
2500	1/2"	1"	2 5/8"	B3
2501	1/2"	1/2"	2 1/8"	B3
1/2" SHANK				
2502	1/2"	1"	3 1/4"	B3
2503	1/2"	1/2"	2 3/4"	B3
2504	1/2"	1 1/2"	3 5/8"	B3
2505	1/2"	2"	4"	B3
1/2" SHANK - DOUBLE BEARING				
2554	1/2"	1 1/2"	3 7/8"	Two B3
2555	1/2"	2"	4 1/4"	Two B3

DOWN SHEAR FLUSH TRIM Two Flute

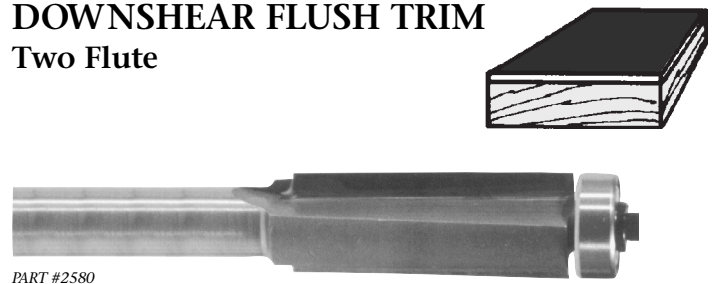

Part Number	Cutting Diameter	Cutting Length	Overall Length	Bearing Number
1/4" SHANK				
2602	1/2"	1"	2 5/8"	B3
2560	3/4"	5/8"	2 1/8"	B4
1/2" SHANK				
2605	1/2"	1"	3 1/4"	B3
2570	3/4"	1"	3"	B4
2575	3/4"	1 1/2"	3 1/2"	B4
2580	3/4"	2"	4"	B4

NEW! FLUSH TRIM - DOWNSHEAR

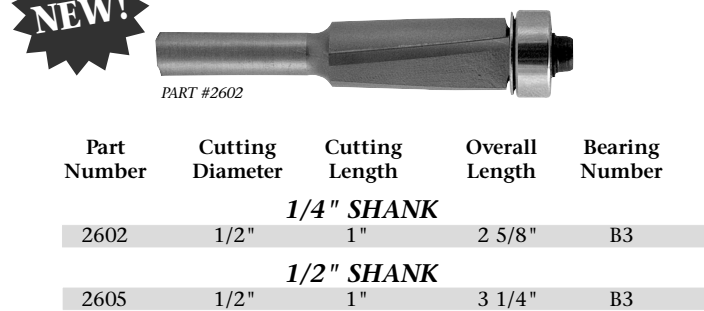

Part Number	Cutting Diameter	Cutting Length	Overall Length	Bearing Number
1/4" SHANK				
2602	1/2"	1"	2 5/8"	B3
1/2" SHANK				
2605	1/2"	1"	3 1/4"	B3

FLUSH TRIM V-GROOVE



Part Number	Cutting Diameter	Cutting Length	Shank Diameter	Overall Length	Bearing Number
2425	1/2"	1"	1/4"	2 5/8"	B3
2426	1/2"	1"	1/2"	3 1/4"	B3

OVERHANG TRIM BIT



Part Number	Overhang	Cutting Diameter	Cutting Length	Bearing Number
1/4" SHANK				
2468	1/16"	3/8"	1/2"	B3
2470	1/8"	3/8"	1/2"	B7

NEW! COMBINATION FLUSH TRIM with Top and Bottom Bearings



Part Number	Cutting Diameter	Cutting Length	Overall Length	Bearing Number
1/4" SHANK				
2702	1/2"	1"	2 5/8"	B3 & B9
1/2" SHANK				
2715	7/8"	1 1/2"	3 1/2"	B13 & B21

Try our solid carbide flush trim spiral bits on page 2.



LAMINATE TRIM

LAMINATE TRIM BITS Two Flute - Ball Bearing



PART #2298



Part Number	Bevel Degree	Large Diameter	Cut Length	Bearing Number
1/4" SHANK				
2401	Flush	3/8"	1/2"	B1
2298	7°	9/16"	7/16"	B3
2300A	15°	5/8"	1/4"	B3
2301	25°	1"	9/16"	B3

LAMINATE TRIMMERS - WITH Euro Square Bearing

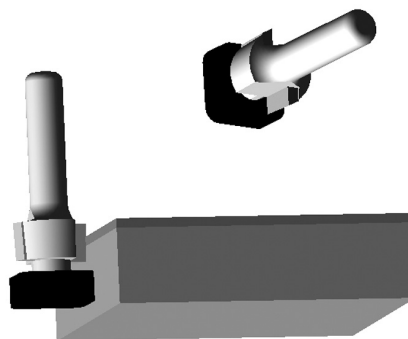

Here's a Square Deal! A quality Whiteside Trim Bit with the exclusive Euro Square Bearing. How does it work? The square bearing stops spinning as soon as it touches the workpiece. Then the side of the square simply slides along the workpiece edge. Compare this to a regular bearing that rolls along the edge - building up more glue and residue with every revolution. Plus, the square is made from non-stick Teflon®, so it wipes clean easily and it won't mark your workpiece. If you cut laminates, you need to try this bit.

STANDARD FLUSH TRIM SOLID CARBIDE



PART # SC28B



Part Number	Cutting Length	Shank Diameter	Overall Length
SC28B	1/4"	1/4"	1 1/2"

7° BEVEL TRIM SOLID CARBIDE



PART # SC29



Part Number	Cutting Length	Shank Diameter	Overall Length
SC29	1/4"	1/4"	1 1/2"

See our complete line of solid carbide trimmers on pages 4 & 5.

COMBINATION FLUSH OR BEVEL LAMINATE TRIM



PART #2801

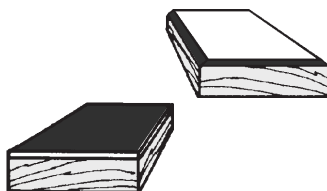

Part Number	Cutting Diameter	Degree of Angle	Cutting Length	Overall Length
1/4" SHANK				
2800	7/16"	22 1/2°	1/2"	1 1/8"
2801	7/16"	22 1/2°	1/2"	1 7/8"

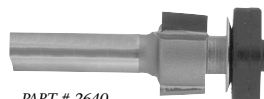

PART # 2640



PART # B3SQ

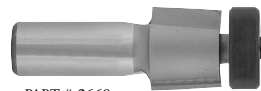

PART # 2660

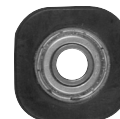

PART # B8SQ

Part Number	Cutting Diameter	Cutting Length	Overall Length	Bearing Number
1/4" SHANK				
2640	1/2"	1/4"	1 5/8"	B3SQ
2650	3/4"	5/8"	2 1/4"	B8SQ
1/2" SHANK				
2660	3/4"	5/8"	2 1/4"	B8SQ

These bits are designed with a slight taper on the cutting diameter. This allows up or down adjustment to achieve an exact blend - even after resharpening.

Euro Square Bearing

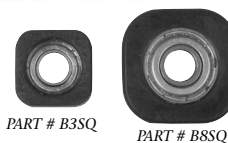

PART # B3SQ

PART # B8SQ

Replace the standard 1/2" B3 bearing found on most of our Edge Form bits with the B3SQ square bearing if residue build-up on the bearing or marring of the workpiece is a problem.

Recommended for solid surface applications. B3SQ is 1/2" square. B8SQ is 3/4" square. Both are standard 3/16" inside diameter.



SOLID SURFACE BITS

ROUND OVER With Non-Marring Bearing

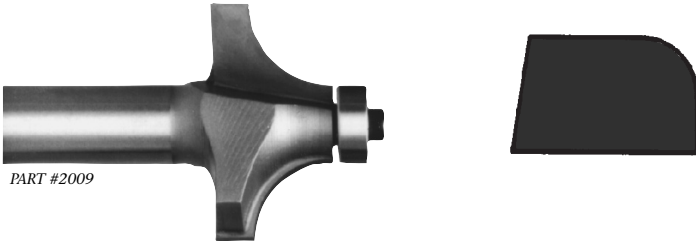

PART #2009

Part Number	Material Thickness	Radius	Overall Length	Bearing Number
-------------	--------------------	--------	----------------	----------------

1/2" SHANK

2006N	1/2"	1/4"	2 1/4"	B3S
2009N	1"	1/2"	2 1/2"	B3S
2010N	1 1/2"	3/4"	2 3/4"	B3S

Supplied With Non-Marring Nylon Sleeved Bearing (Part #B3S).

ROUNDING OVER UNDERMOUNT

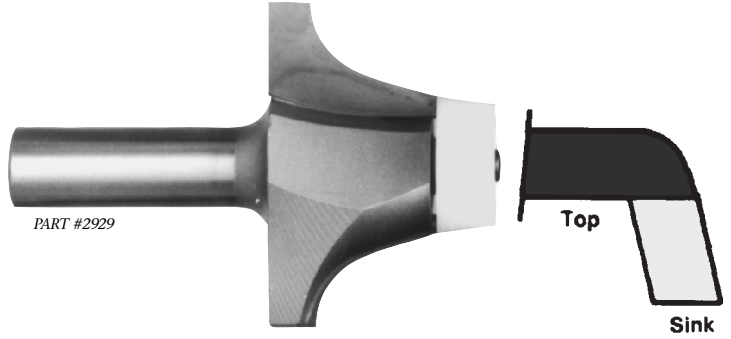

PART #2929

Part Number	Material Thickness	Degree	Overall Length	Bearing Number
-------------	--------------------	--------	----------------	----------------

1/2" SHANK

2929	1/2"	18°	3"	BB300
2930	3/4"	18°	3 1/4"	BB300

ROUNDING UNDER

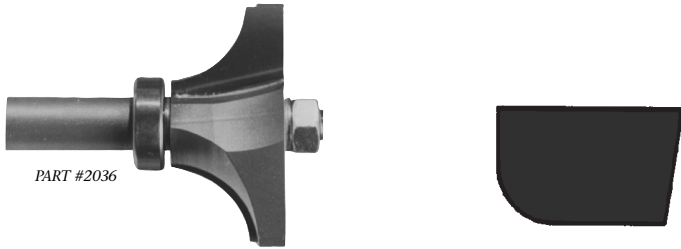

PART #2036

Part Number	Material Thickness	Radius	Overall Length	Bearing Number
-------------	--------------------	--------	----------------	----------------

1/2" SHANK

2030	1/2"	1/4"	2 3/4"	B5
2034	1"	1/2"	3"	B5
2036	1 1/2"	3/4"	3 3/8"	B5

BEVEL UNDERMOUNT BOWL

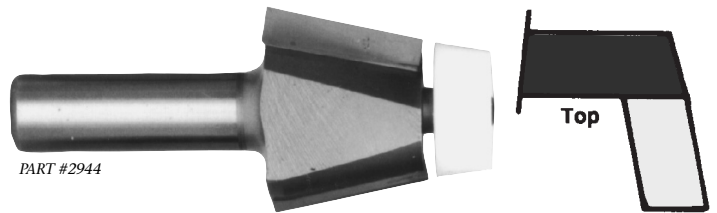

PART #2944

Part Number	Material Thickness	Degree	Overall Length	Bearing Number
-------------	--------------------	--------	----------------	----------------

1/2" SHANK

2944	1/2-3/4"	12°	3"	BB300
------	----------	-----	----	-------

FACE INLAY

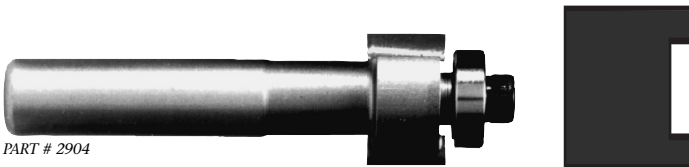

PART #2904

Part Number	Cutting Diameter	Cutting Length	Cutting Depth	Overall Length	Bearing Number
-------------	------------------	----------------	---------------	----------------	----------------

1/2" SHANK

2900	7/8"	1/4"	1/16"	2 3/4"	B4
2901	7/8"	1/4"	1/8"	2 3/4"	B6
2902	7/8"	1/4"	3/16"	2 3/4"	B9
2903	7/8"	1/2"	1/16"	3"	B4
2904	7/8"	1/2"	1/8"	3"	B6
2905	7/8"	1/2"	3/16"	3"	B9
2906	7/8"	3/4"	1/16"	3 1/4"	B4
2907	7/8"	3/4"	1/8"	3 1/4"	B6
2908	7/8"	3/4"	3/16"	3 1/4"	B9

OVERHANG BOWL TRIM

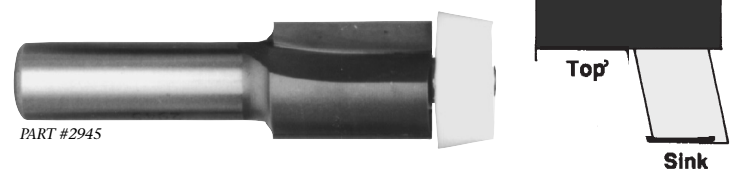

PART #2945

Part Number	Material Thickness	Cutting Diameter	Overall Length	Bearing Number
-------------	--------------------	------------------	----------------	----------------

1/2" SHANK

2945	1/2-3/4"	3/4"	2 7/8"	BB300
------	----------	------	--------	-------



TEMPLATE • T-SLOT

TEMPLATE BITS Ball Bearing Guide



PART #3012

Part Number	Cutting Diameter	Cutting Length	Overall Length	Bearing Number
1/4" SHANK				
* 3000A	1/2"	1/8"	1 3/4"	B9
* 3000	1/2"	1/4"	1 7/8"	B9
NEW! 3001	1/2"	1/2"	2"	B9
3002	1/2"	3/4"	2 1/4"	B9
3004	1/2"	1"	2 1/2"	B9
* 3006	5/8"	1/4"	1 3/4"	B6
K41	5/8"	1/2"	2 1/4"	B6
K43	5/8"	3/4"	2 1/2"	B6
3008	5/8"	1"	2 1/2"	B6
* 3010	3/4"	1/4"	1 3/4"	B4
3012	3/4"	3/4"	2 3/8"	B4
3014	3/4"	1"	2 5/8"	B4
3/8" SHANK				
3015	7/8"	1"	2 5/8"	B12
1/2" SHANK				
3016	1 1/8"	1"	3"	B11
3018	1 1/8"	1 1/2"	3 1/2"	B11
3019	1 1/8"	2"	4"	B11
*** 3020	3/4"	1"	2 3/4"	***B19
*** 3021	3/4"	1 1/4"	3"	***B19
*** 3022	3/4"	1 1/2"	3 1/4"	***B19
NEW! 3022A	7/8"	1 1/2"	3 1/2"	B13
*** 3023	3/4"	2"	3 5/8"	***B19

* Dado Clean out bits. Use to Square the bottom of dado cuts made on a table saw.
 *** Whiteside recommends using bits over 3/4" diameter in 1/2" shank whenever possible due to the fragile nature of the B19 bearing.

TEMPLATE BITS With Oversize Bearings

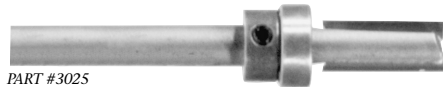

PART #3025

Part Number	Cutting Diameter	Cutting Length	Overall Length	Bearing Diameter	Bearing Number
1/4" SHANK					
NEW! 1 3025	5/16"	3/4"	2 3/4"	1/2"	B9
2 3027	1/2"	1/4"	1 7/8"	5/8"	B6
3 3028	1/2"	1/4"	1 7/8"	3/4"	B4
1,4 3032	9/16"	3/4"	2 1/4"	5/8"	B6

¹ For Porter-Cable Morten™, Mortise & Tenon Jig, and Omnijig® templates
² Porter-Cable Hinge Butt Mortise Bit
³ For Hinge-Mate™ II Template
⁴ Keller Box Joint Bit

KEYHOLE BITS



PART #3050

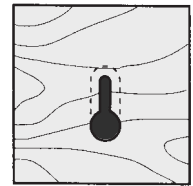

Part Number	Large Diameter	Small Diameter	Cutting Length	Overall Length
1/4" SHANK				
3050	3/8"	3/16"	7/16"	1 1/2"
3052	1/2"	5/16"	7/16"	1 1/2"
1/2" SHANK				
3051	3/8"	3/16"	7/16"	2 1/8"
3053	1/2"	5/16"	7/16"	2 1/8"

T-SLOT CUTTER

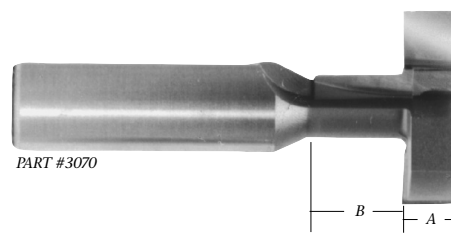

PART #3070

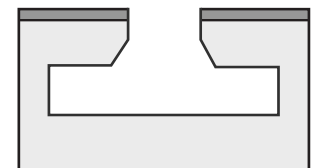
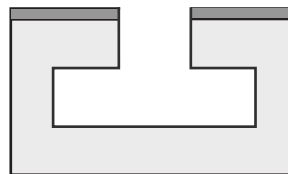

PART # 3070
ACTUAL SIZE

PART # 3075
ACTUAL SIZE

Part Number	Large Diameter	Small Diameter	"A" Length	"B" Length	Overall Length
1/2" SHANK					
3070	1 1/16"	3/8"	5/16"	1/2"	2 3/8"
3075	1 3/16"	3/8"	1/4"	3/8"	2 3/8"

SLOT & UNDERCUT BITS

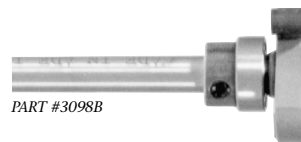

PART #3098B

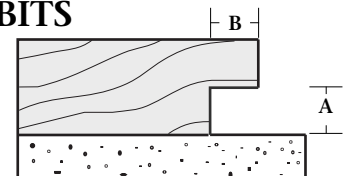

Used to cut all types of slots and grooves. Also used to undercut decorative patterns or large letters to give them a bold appearance.

Part Number	Large Diameter	"A" Length	"B" Depth	Overall Length
1/4" SHANK				
3094	3/4"	1/8"	1/4"	1 7/8"
* 3094B	3/4"	1/8"	1/8"	1 7/8"
3098	1"	1/4"	3/8"	2"
* 3098B	1"	1/4"	1/4"	2"
3110	1 1/2"	1/4"	5/8"	2"
* 3110B	1 1/2"	1/4"	1/2"	2"

* B denotes Bearing (B9) guide on shank.



EDGE PROFILES

CLASSICAL COVE

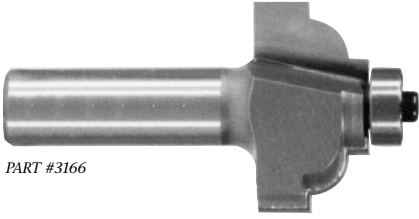

PART #3166

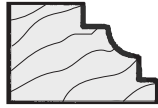

PART #3160/3164



PART #3162/3166
ACTUAL SIZE

Part Number	Radius	Large Diameter	Cutting Length	Overall Length
1/4" SHANK				
3160	5/32"	1 1/4"	1/2"	2"
3162	1/4"	1 3/8"	3/4"	2 1/4"
1/2" SHANK				
3164	5/32"	1 1/4"	1/2"	2 1/4"
3166	1/4"	1 3/8"	3/4"	2 1/2"

Bearing Number: B3

FULL BEAD



PART #3192



#3190

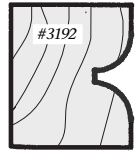

#3192

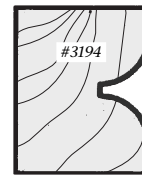

#3194

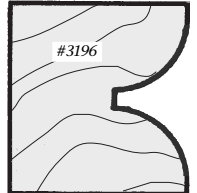

#3196

ACTUAL SIZE PROFILES

Part Number	Radius	Large Diameter	Cutting Length	Overall Length
1/4" SHANK				
3190	1/8"	7/8"	5/16"	2 1/8"
3192	3/16"	1"	1/2"	2 3/8"
3194	1/4"	1 1/8"	5/8"	2 1/2"
3196	3/8"	1 3/8"	7/8"	2 3/4"

Bearing Number: One B6 & One B7

WAVY EDGE

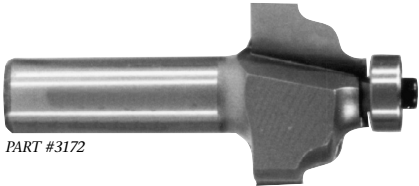

PART #3172

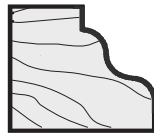

ACTUAL SIZE

Part Number	Radius	Large Diameter	Cutting Length	Overall Length
1/4" SHANK				
3170	1/8"	1 1/4"	3/4"	2 1/4"
1/2" SHANK				
3172	1/8"	1 1/4"	3/4"	2 1/2"

Bearing Number: B3

MULTI-BEADING

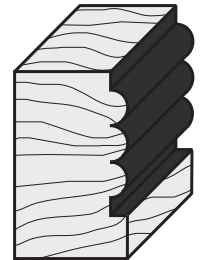
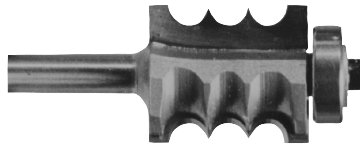

Part Number	Radius	Large Diameter	Cutting Length	Overall Length
-------------	--------	----------------	----------------	----------------

1/4" SHANK				
3200	1/8"	7/8"	1"	2 1/2"

1/2" SHANK				
3202	1/8"	7/8"	1"	2 3/4"

Bearing Number: B3

RADIUS FLUTE CUTTER

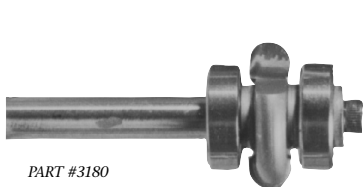

PART #3180



PART #3180/3181

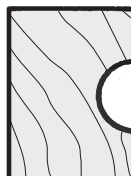

PART #3182/3183

ACTUAL SIZE

Part Number	Radius	Large Diameter	Cutting Length	Overall Length
1/4" SHANK				
3180	1/8"	1 1/8"	1/4"	2 5/8"
3182	3/16"	1 1/4"	3/8"	3 1/8"
1/2" SHANK				
3181	1/8"	1 1/8"	1/4"	2 3/4"
3183	3/16"	1 1/4"	3/8"	3 1/8"

Bearing Number: Two B5

DOUBLE ROUND

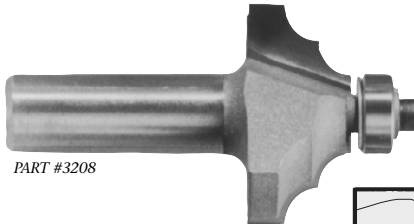

PART #3208



PART #3205/3207



PART #3206/3208

ACTUAL SIZE

Part Number	Radius	Large Diameter	Cutting Length	Overall Length
-------------	--------	----------------	----------------	----------------

1/4" SHANK				
3205	5/32"	1 1/8"	1/2"	2"
3206	7/32"	1 3/8"	5/8"	2 1/4"

1/2" SHANK				
3207	5/32"	1 1/8"	1/2"	2 1/4"
3208	7/32"	1 3/8"	5/8"	2 1/2"

Bearing Number: B3



EDGE PROFILES

COVE & BEAD

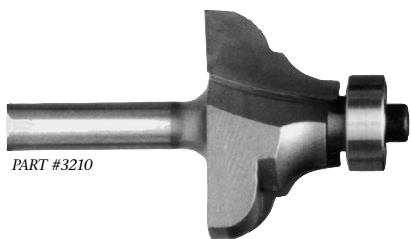

PART #3210

ACTUAL SIZE
3209 & 3211



ACTUAL SIZE
3210 & 3212

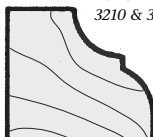

Part Number	Radius	Large Diameter	Cutting Length	Overall Length
1/4" SHANK				
3209	5/32"	1 1/8"	1/2"	2"
3210	1/4"	1 5/16"	5/8"	2 1/8"
1/2" SHANK				
3211	5/32"	1 1/8"	1/2"	2 1/4"
3212	1/4"	1 5/16"	5/8"	2 3/8"
3282	3/8"	2"	1 3/16"	2 7/8"

Bearing Number: B3

OGEE FILLET

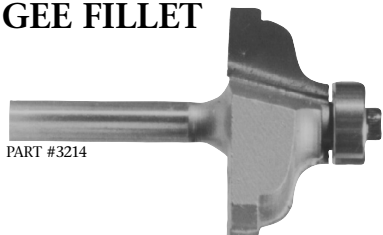

PART #3214

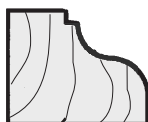

ACTUAL SIZE
3214 & 3216

Part Number	Radius	Large Diameter	Cutting Length	Overall Length
1/4" SHANK				
3214	3/16"	1 3/8"	5/8"	2 1/8"
1/2" SHANK				
3216	3/16"	1 3/8"	5/8"	2 1/2"
3218	1/4"	1 5/8"	3/4"	2 5/8"

Bearing Number: B3

OGEE

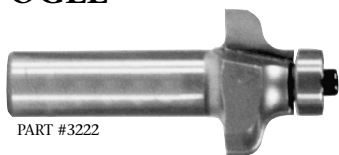

PART #3222

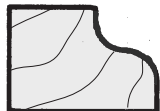

3220 & 3222

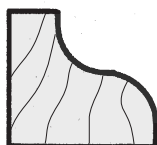

3224 & 3226

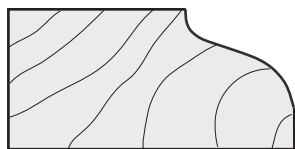

3228

Part Number	Radius	Large Diameter	Cutting Length	Overall Length
1/4" SHANK				
3220	5/32"	1 1/8"	1/2"	2"
3224	1/4"	1 1/2"	5/8"	2 1/8"
1/2" SHANK				
3222	5/32"	1 1/8"	1/2"	2 1/4"
3226	1/4"	1 1/2"	5/8"	2 3/8"
3228	9/64" & 5/16"	1 5/8"	5/8"	2 1/2"

Bearing Number: B3

CLASSICAL PATTERN

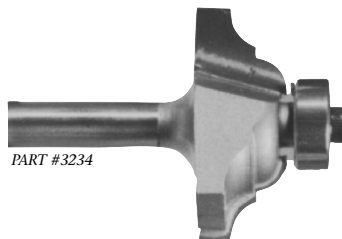

PART #3234

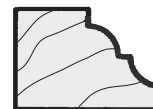

3230 & 3232

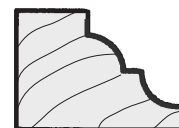

ACTUAL SIZES
3234 & 3236

Part Number	Radius	Large Diameter	Cutting Length	Overall Length
1/4" SHANK				
3230	5/32"	1 1/4"	1/2"	2 1/8"
3234	3/16"	1 1/2"	5/8"	2 1/4"
1/2" SHANK				
3232	5/32"	1 1/4"	1/2"	2 3/8"
3236	3/16"	1 1/2"	5/8"	2 1/2"

Bearing Number: B3

EDGE BEADING

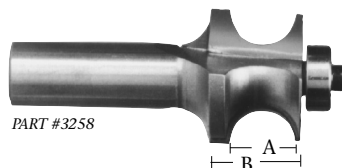

PART #3258



3244 & 3246
ACTUAL SIZES



3252 & 3254

Part Number	Large Diameter	"A" Bead Diameter	"B" Cutting Length	Overall Length
1/4" SHANK				
3240	7/8"	1/8"	9/16"	2"
3244	7/8"	1/4"	9/16"	2"
3248	1"	5/16"	5/8"	2 1/4"
3252	1 1/16"	3/8"	3/4"	2 1/4"
3256	1 1/16"	1/2"	3/4"	2 1/4"
1/2" SHANK				
3242	7/8"	1/8"	9/16"	2 1/4"
3246	7/8"	1/4"	9/16"	2 1/4"
3250	1"	5/16"	5/8"	2 1/4"
3254	1 1/16"	3/8"	3/4"	2 1/2"
3258	1 1/16"	1/2"	3/4"	2 1/2"
3260	1 3/8"	5/8"	1"	2 5/8"
3262	1 1/2"	3/4"	1 1/8"	3"

Bearing Number: B3

FRENCH TRADITIONAL

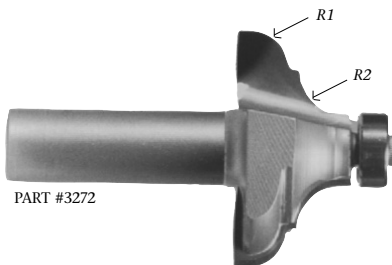

PART #3272

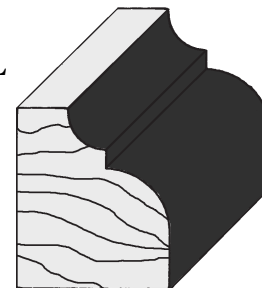

ACTUAL SIZE
3270 & 3272

Part Number	"R1" Radius	"R2" Radius	Large Diameter	Cutting Length	Overall Length
1/4" SHANK					
3270	3/16"	5/16"	1 1/2"	5/8"	2 1/8"
1/2" SHANK					
3272	3/16"	5/16"	1 1/2"	5/8"	2 1/2"

Bearing Number: B3



EDGE PROFILES

FRENCH PROVINCIAL MOLDING

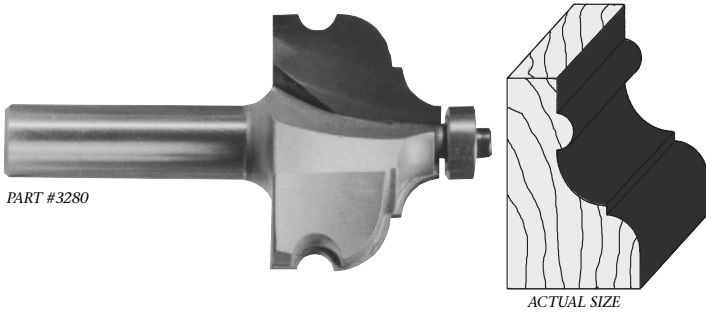

Part Number	Large Diameter	Cutting Length	Bead Diameter	Overall Length
1/2" SHANK				
3280	1 3/4"	1 1/8"	3/4"	3 1/8"

Bearing Number: B3

*3282 - See Cove & Bead Bits on Pg. 19.

CLASSICAL OGEE TABLE EDGE

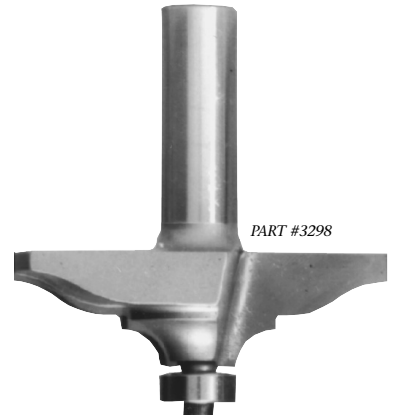
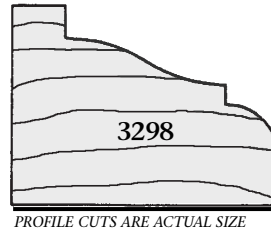

Part Number	Profile Width	Large Diameter	Cutting Length	Overall Length
1/2" SHANK				
3298	1"	2 1/2"	3/4"	2 1/2"

Bearing Number: B3

THUMBNAIL TABLE EDGE

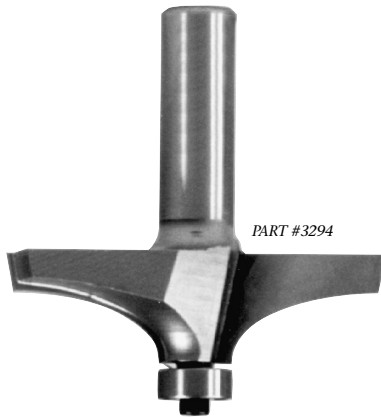
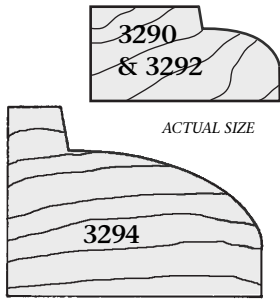

Part Number	Profile Width	Large Diameter	Cutting Length	Overall Length
1/4" SHANK				
3290	7/16"	1 3/8"	3/8"	1 7/8"
1/2" SHANK				
3292	7/16"	1 3/8"	3/8"	2"
3294	1"	2 1/2"	3/4"	2 1/2"

Bearing Number: B3

FRENCH BAROQUE TABLE EDGE

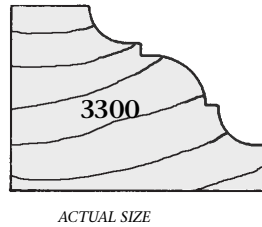

Part Number	Profile Width	Large Diameter	Cutting Length	Overall Length
1/2" SHANK				
3300	7/8"	2 1/4"	3/4"	2 1/2"

Bearing Number: B3

TRADITIONAL TABLE EDGE

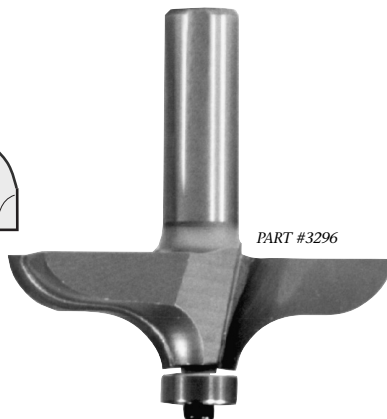
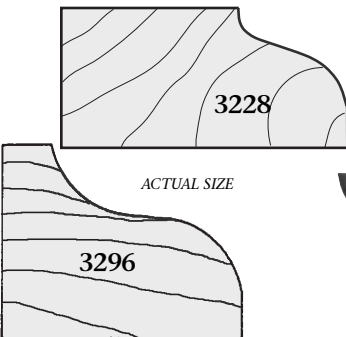

Part Number	Profile Width	Large Diameter	Cutting Length	Overall Length
1/2" SHANK				
3228	9/16"	1 5/8"	5/8"	2 1/2"
3296	1"	2 1/2"	3/4"	2 1/2"

Bearing Number: B3

THUMBNAIL & BEAD TABLE EDGE

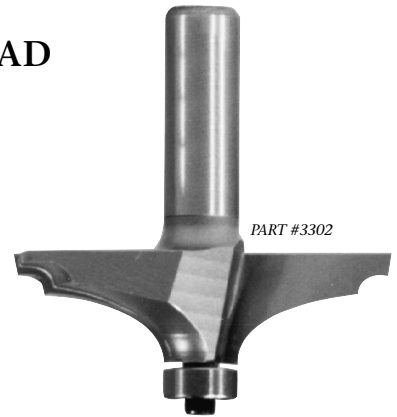
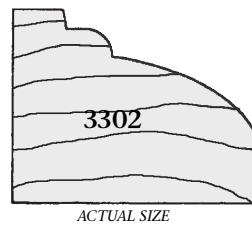

Part Number	Profile Width	Large Diameter	Cutting Length	Overall Length
1/2" SHANK				
3302	1"	2 1/2"	3/4"	2 1/2"

Bearing Number: B3



HANDRAIL & MOLDING

HANDRAIL BITS

Used to cut the lower portion of the handrail profile.

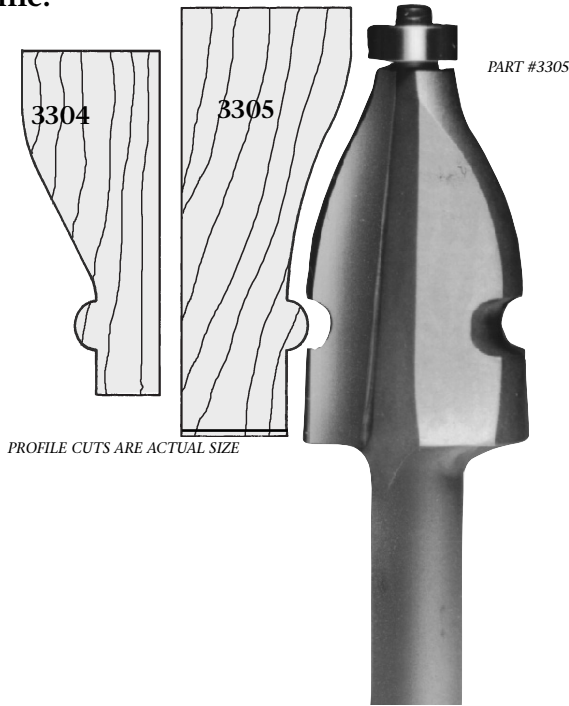

PROFILE CUTS ARE ACTUAL SIZE

Part Number	Large Diameter	Cutting Length	Bead Diameter	Overall Length
1/2" SHANK				
3304	1 3/8"	1 1/2"	1/4"	3 3/8"
3305	1 1/4"	2"	1/4"	3 7/8"

Bearing Number: B3

HANDRAIL PROFILES

Here are some examples of the handrail profiles which are possible using the handrail bits above in combination with your choice of the table edge bits from page 20.

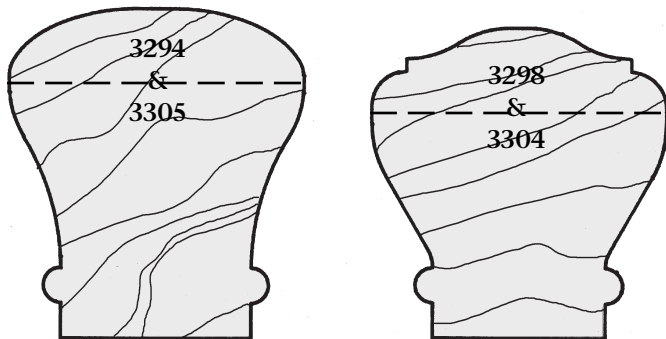

PROFILES ARE SHOWN SMALLER THAN ACTUAL SIZE

SPECIALTY MOLDING

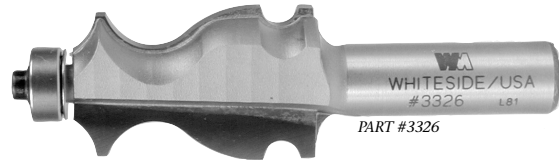

PART #3326

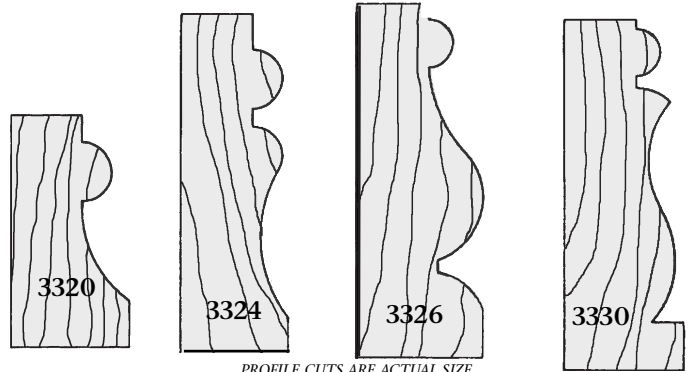

PROFILE CUTS ARE ACTUAL SIZE

Part Number	Large Diameter	Cutting Length	Bead Diameter	Overall Length
1/2" SHANK				
3320	1"	1"	5/16"	2 3/4"
3324	7/8"	1 5/8"	5/16"	3 1/2"
3326	1 1/16"	1 5/8"	1/4"	3 1/2"
3330	1"	1 5/8"	1/4"	3 1/2"

Bearing Number: B3

CLASSIC MULTI-FORMS

Many distinct profiles are possible by using different sections of this tool.

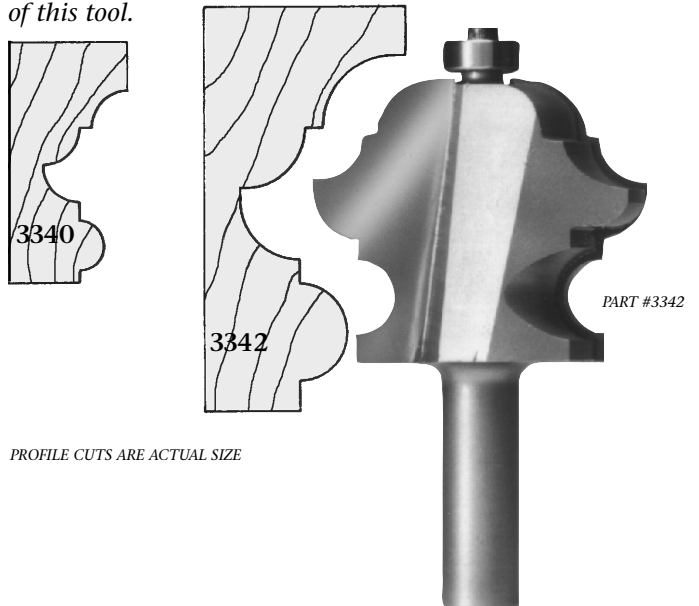

PROFILE CUTS ARE ACTUAL SIZE

Part Number	Large Diameter	Cutting Length	Bead Diameter	Radius	Overall Length
1/2" SHANK					
3340	1 3/8"	1"	1/4"	3/16"	2 3/4"
3342	2 1/4"	1 7/8"	1/2"	5/16"	3 3/4"

Bearing Number: B3



GLUE JOINTS

LOCKING DRAWER GLUE JOINTS

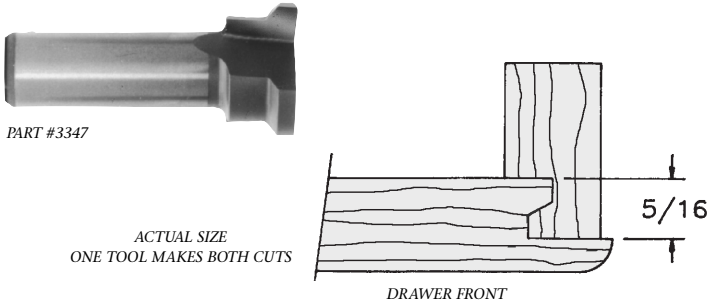

Part Number	Large Diameter	Cutting Length	Shank Diameter	Overall Length
3346	3/4"	1/2"	1/4"	1 7/8"
3347	1"	1/2"	1/2"	2 1/8"

45° LOCK MITER

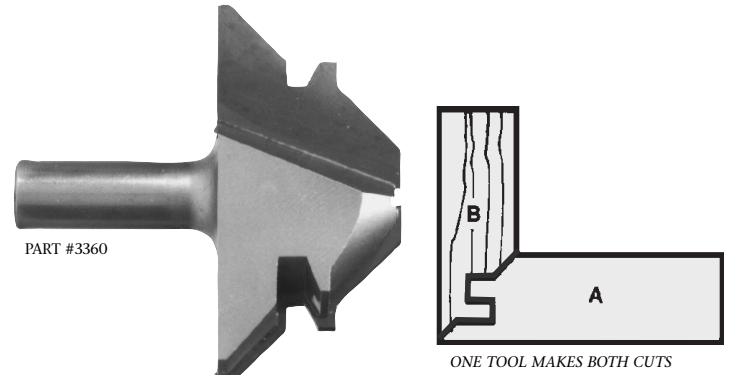

Part Number	Material Thickness	Large Diameter	Shank Diameter	Overall Length
3360	1/2-1 1/4"	3 1/8"	1/2"	2 7/8"
3362	1/2-3/4"	2"	1/2"	2 3/8"

Note: 3362 is recommended for stock thickness 1/2 - 3/4"

LOCKING DRAWER GLUE JOINTS

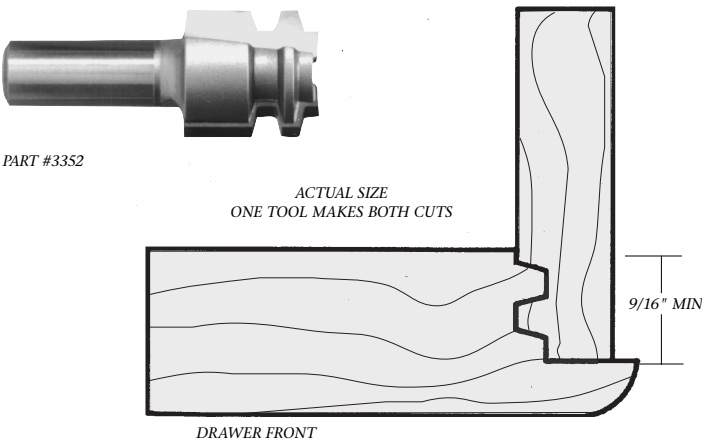

Part Number	Large Diameter	Cutting Length	Shank Diameter	Overall Length
3350	1"	1"	1/4"	2 3/8"
3352	1"	1"	1/2"	2 3/8"

WEDGE TONGUE & GROOVE

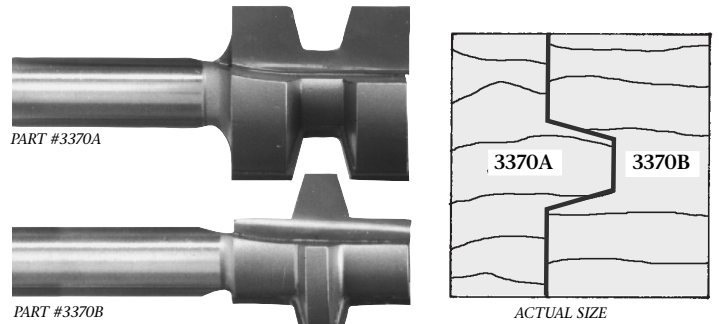

Part Number	Material Thickness	Large Diameter	Cutting Length	Overall Length
1/2" SHANK				
3370	5/8-1 1/4"	1 1/4"	1 1/4"	2 7/8"

*Order 3370 for Two Piece Set.

*Order 3370A or 3370B for individual cutters.

STRAIGHT TONGUE & GROOVE

Ball Bearing Guide

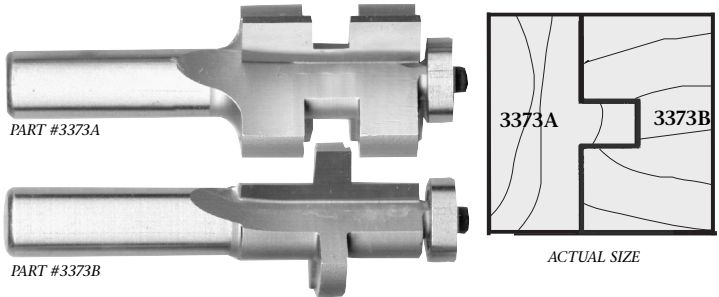

Part Number	Material Thickness	Large Diameter	Cutting Length	Overall Length
1/2" SHANK				
3373	1/2" - 1 1/4"	1 1/4"	1 1/4"	3 1/8"

* Order 3373 for two piece set

* Order 3373A or 3373B for individual cutters.

Bearing Number: B7

STANDARD GLUE JOINT

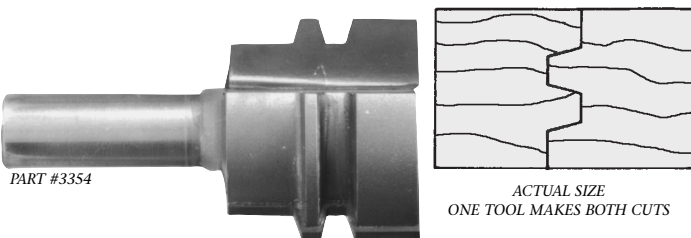

Part Number	Material Thickness	Large Diameter	Shank Diameter	Overall Length
3354	1/2-1 1/4"	1 1/2"	1/2"	2 3/4"



GLUE JOINTS

VEE PANEL TONGUE & GROOVE Ball Bearing Guide

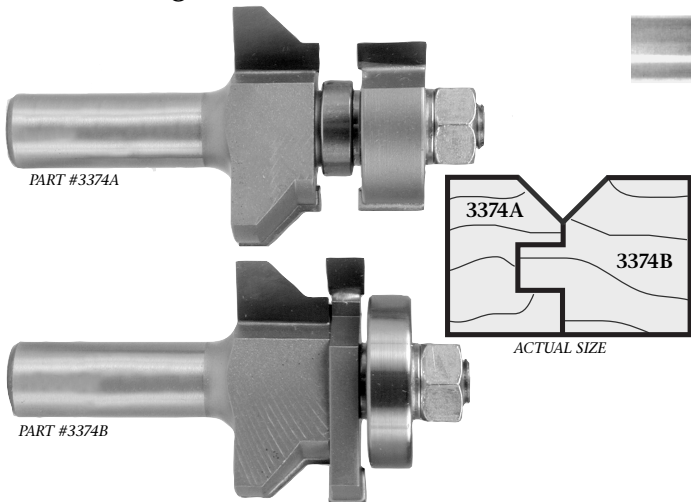

Part Number	Material Thickness	Large Diameter	Cutting Length	Overall Length
1/2" SHANK				
3374	5/8-1"*	1 5/8"	1"	2 3/4"

Order 3374 for two piece set.

Order 3374A or 3374B for individual cutters.

* Material over 1" thick requires a second cut on the tongue profile to waste away excess stock.

FINE FINGER JOINT

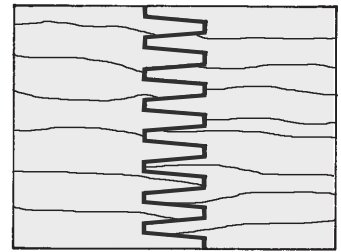
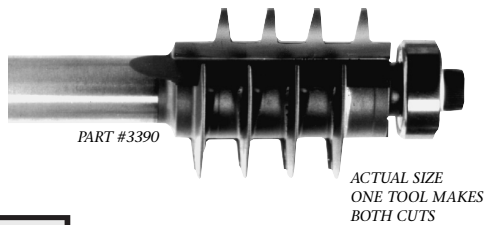

Part Number	Material Thickness	Large Diameter	Finger Depth	Overall Length
1/2" SHANK				
3390	5/16-1 1/4"	1 3/8"	5/16"	3 1/4"

Bearing Number: B4

MULTI SIDE BITS

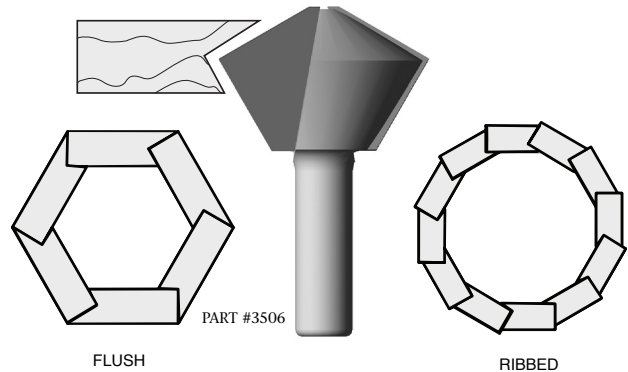

A great way to join up many multi-side projects (planters, columns, barrels, etc.). Very straightforward, this joint requires routing a notch in only one edge of each stave (side). Notching also improves ease of assembly and total glue area. All bits are 1/2" shank and are designed for use in a router table with a fence guide.

Part Number	Number of Sides	Stock (Maximum)	Large Diameter
1/2" SHANK			
3506	6 or 12	7/8"	1 7/8"
3508	8	7/8"	1 3/4"
3516	16	1"	1 5/8"

On six and eight sided objects, the exterior side is cut face up on a router table. Twelve and sixteen sided objects are cut face down. The same bit (#3506) is used for six sided and twelve sided objects.

Either Flush or Ribbed (outside corners protruding) construction is possible. Ribbed construction is recommended with 12 and 16 sides because the interior leg of the notch will be very small when made flush. Outside corners on ribbed construction can be cut or sanded down for flush appearance if desired.

Location of the inside corner of the notch (i.e.- vertical bit adjustment) is important for final finish appearance. The outside leg of the notch (closest to the exterior) should be the same length as the stock thickness for flush construction. This will put the inside corner of the notch in the center of the stave on six sided flush projects. The inside corner will be below center (furthest from exterior side) on all others. Allow extra stock to experiment and set corner height as desired. Move notch towards exterior side (raise the bit) to increase rib size (amount of outside corner protruding). Move notch away from exterior side (lower the bit) to decrease amount of rib. Note: Bit adjustment is reversed on twelve and sixteen sides since those staves are cut face down.

TONGUE & GROOVE ASSEMBLY

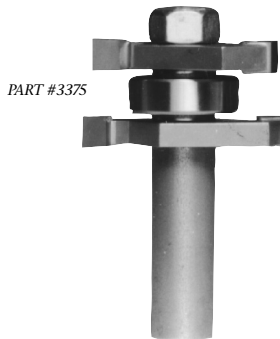
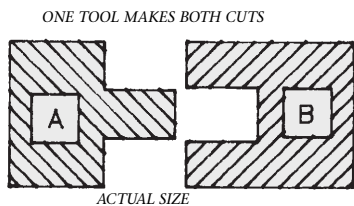

Part Number	Material Thickness	Large Diameter	Tongue Width	Bearing
1/2" SHANK				
3375	1/2"-13/16"	1 5/8"	9/32"	B5

Replacement Parts: Groover - 6628
Arbor - A260

USING THE TONGUE & GROOVE ASSEMBLY

Cutting the Tongue

Cutting the Groove

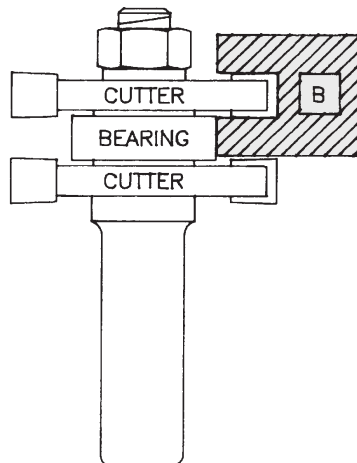
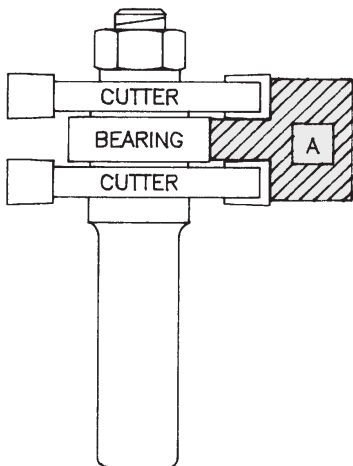



GROOVE PROFILES

Small Grooving Bits are commonly used for decorative designs in cabinet doors or for detail veining in furniture. Round Nose Bits (pg. 9) and V-Groove Bits (pg. 10) are often used in the same manner. The Larger Grooving Bits are great for a raised panel effect in doors and for adding a bold accent to furniture or large workpieces. These bits also make nice edge profiles with the aid of a router table and fence.

These bits are ideal for adding bearings to the shank for following templates. Select a bearing from page 35 with the same inside diameter as your shank size. Outside diameter should be the same size or larger than the large diameter of your router bit. Secure bearings with a lock collar. Use Lock Collar #LC-1/4 for 1/4" shanks or LC-1/2 for 1/2" shanks.

CLASSICAL FLAT BOTTOM

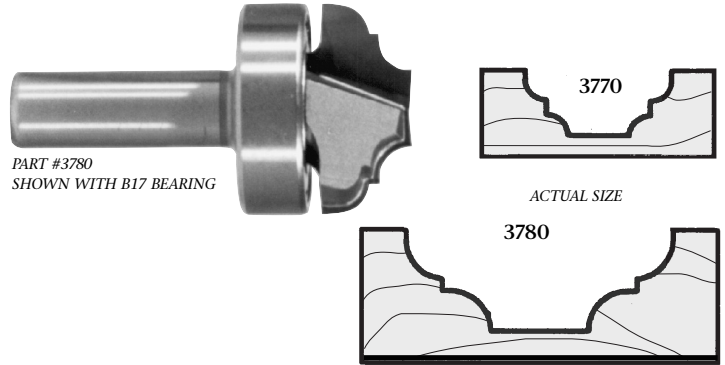

Part Number	Radius	Large Diameter	Cutting Length	Overall Length
1/4" SHANK				
3770	7/64"	3/4"	3/8"	2"
1/2" SHANK				
3780	13/64"	1 3/8"	9/16"	2 1/2"

PLUNGE OGEE

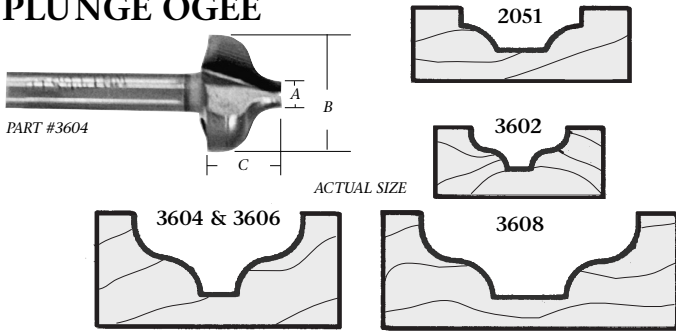

Part Number	Radius	Small Diameter	Large Diameter	Cutting Length	Overall Length
1/4" SHANK					
2051	3/16"	1/4"	5/8"	3/8"	1 3/4"
3602	3/32"	1/8"	1/2"	1/4"	1 3/4"
3604	3/16"	3/16"	7/8"	1/2"	2"
1/2" SHANK					
3606	3/16"	3/16"	7/8"	1/2"	2"
3608	3/16"	3/8"	1 1/8"	1/2"	2 1/4"

CLASSICAL ROUND BOTTOM

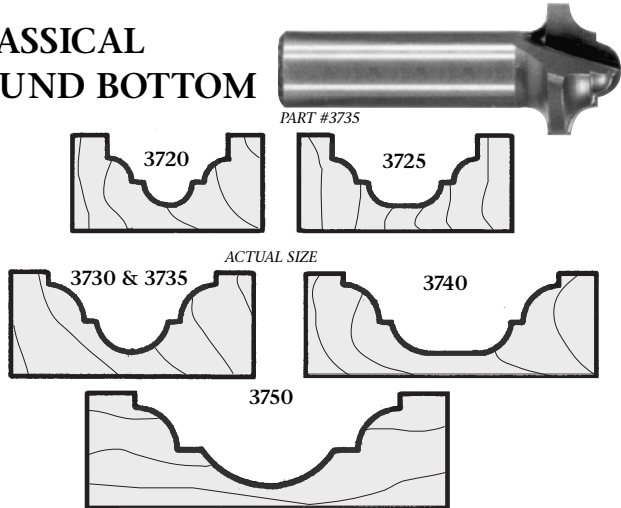

Part Number	Radius	Large Diameter	Cutting Length	Overall Length
1/4" SHANK				
3720	1/8"	5/8"	1/2"	2"
3725	1/8"	3/4"	1/2"	2"
3730	3/16"	7/8"	1/2"	2"
1/2" SHANK				
3735	3/16"	7/8"	1/2"	2 1/8"
3740	3/16"	1 1/8"	1/2"	2 1/8"
3750	7/32"	1 3/8"	9/16"	2 1/2"

MODEL TRAIN TRACK BITS

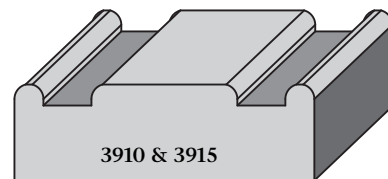
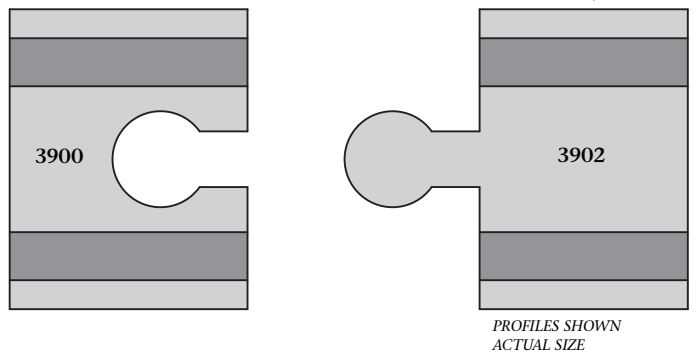
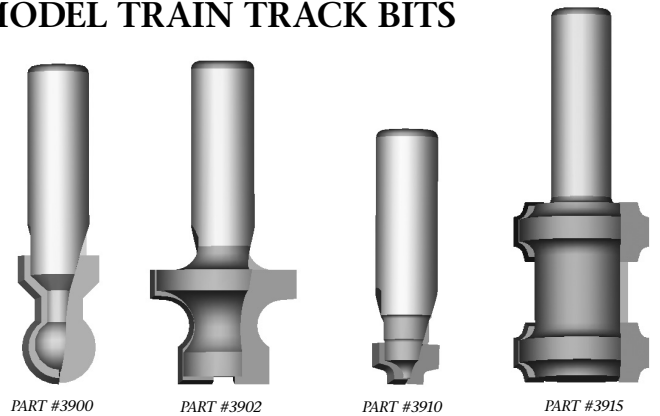

Part Number	Description	Large Diameter	Cutting Length
3900	Female Connector (Ball Cutter)	1/2"	3/4"
3902	Male Connector (Half Round Cutter)	1 3/16"	11/16"
3910	Track Single Groove Bit	1/2"	1/4"
3915	Track Double Groove Bit	1 1/8"	1 1/2"



MDF DOORS

The Tooling on this page is designed to give the illusion of raised panel door construction in MDF and solid panel doors. These bits, when used individually, produce a nice simple raised panel effect in one pass. Or use one of the "Panel" bits in conjunction with one of the "Stile" bits to create a more authentic raised panel reveal. Many different combinations are possible. See Bottom of Page.

Although designed for production routing on solid door machines and CNC routers, the addition of a bearing to the shank will allow the hobbyist to cut his pattern by following an edge guide. The guide can be four strips clamped around the perimeter of the door. The top strip may be curved for an arched pattern. Follow the guide and rout both profiles. There's no need to move the guide for the second cut. A larger bearing on the panel bit takes care of the offset. Use **Bearing #B16 for the Stile bits and Bearing #B24 for the Panel bits. Secure the bearings to the shank with a #LC-1/2 Lock Collar (see pg. 35).** When making the second cut, match the depth setting of the first cut to obtain a pattern with a flat bottom — Or vary the depth to add an extra distinctive "step" in the bottom of your reveal. Complete the door by adding a door edge pattern (see Pg. 29) around the outside edge.

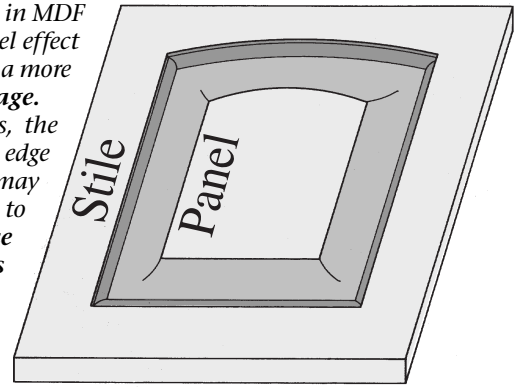

"STILE" PROFILE BITS

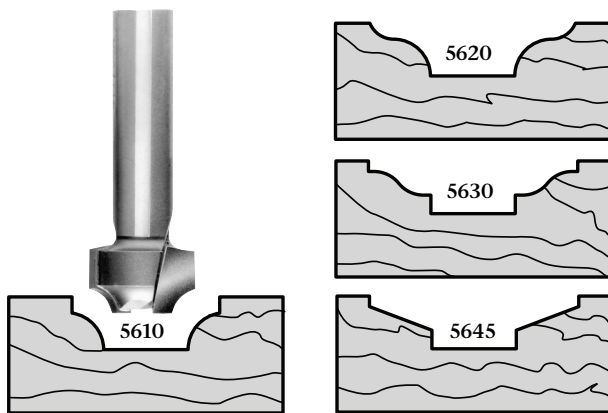

"PANEL" PROFILE BITS

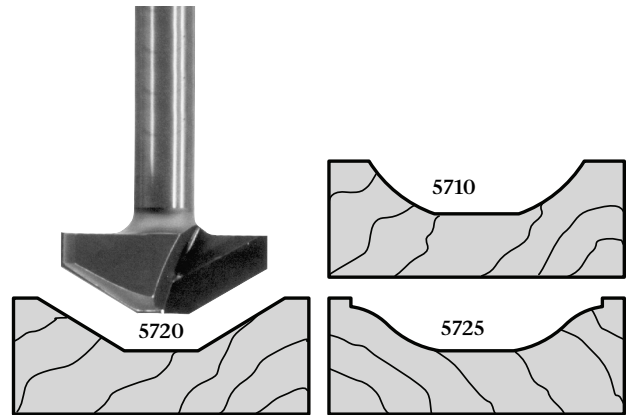

PROFILES SHOWN ACTUAL SIZE

Part Number	Style	Large Diameter	Overall Length
1/2" SHANK			
5610	Bead	7/8"	2 1/2"
5620	Traditional	1 1/4"	2 1/2"
5630	Ogee	1 1/4"	2 1/2"
5645	Straight	1 1/4"	2 1/2"

Part Number	Style	Large Diameter	Overall Length
1/2" SHANK			
5710	Cove	1 1/2"	2 1/2"
5720	Straight	1 1/2"	2 1/2"
5725	Ogee	1 1/2"	2 1/2"

STILE & PANEL COMBINATION PROFILES

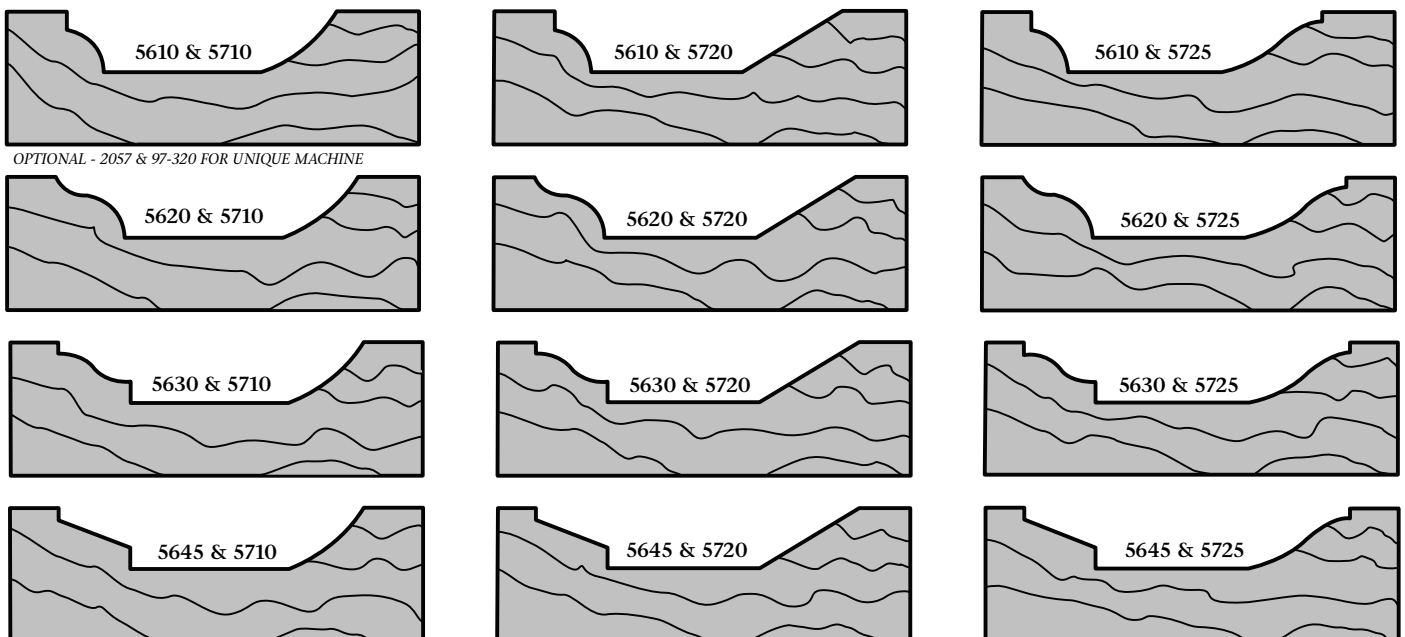

OPTIONAL - 2057 & 97-320 FOR UNIQUE MACHINE



STILE & RAIL

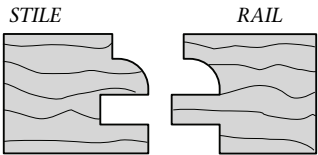

5740 - ROUND

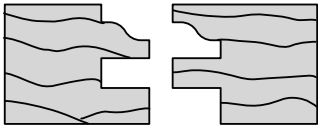

5742 - OGEE

MINIATURE STILE & RAIL

These miniature Stile and Rail sets work just like their full size counterparts (see below). They feature a reduced pattern and a reduced tongue and groove (5/32" x 1/4") suitable for smaller projects. Works with 7/16" to 3/4" thick stock.

Set Number	Pattern	Reveal Width	Large Diameter	Stock Size
1/2" SHANK				
5740	Round	3/16"	1 1/8"	7/16"-3/4"
5742	Ogee	1/4"	1 1/8"	7/16"-3/4"

For Individual Bits: Add A to Part Number for Stile Cutter.
Add B to Part Number for Rail Cutter.
Example: 5740A - Round Stile Cutter
Stile Groover - 5740AG
Rail Groover - 5740BG
Bearing - B27

Replacement Parts:

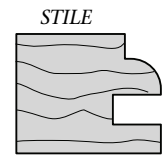

5740 - ROUND

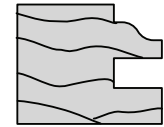

5742 - OGEE

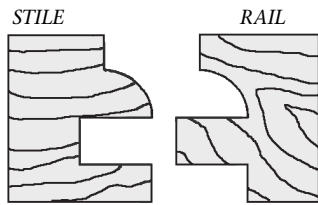

6001 - ROUND

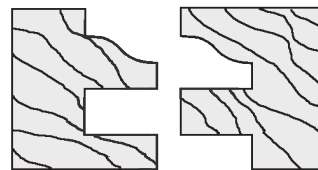

6002 - OGEE

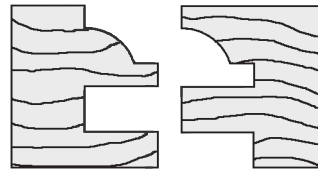

6003 - BEAD

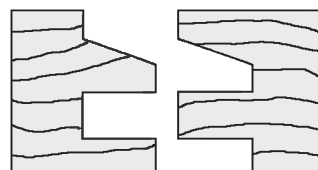

6004 - STRAIGHT

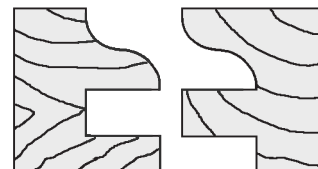

6005 - TRADITIONAL

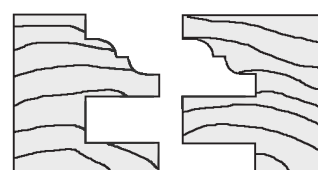

6006 - CLASSICAL

FULL SIZE STILE & RAIL

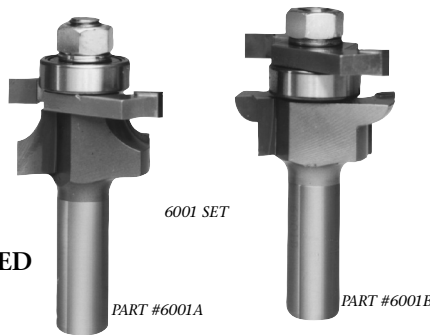

6001 SET

PART #6001A

PART #6001B

MATCHED SETS

Make full size Stile and Rail joints on your router table. The interlocking design plus the raised panel groove are both cut in one pass. Ball bearing guides control the cutting depth and also allow use on rounded, arched, or special shaped doors. With these two piece sets, simply switch router bits to change from cutting stiles to cutting rails. Ideal for stock from 5/8" to 7/8" thick.

Set Number	Pattern	Reveal Width	Cutting Length	Large Diameter
1/2" SHANK				
6001	Round	1/4"	1"	1 5/8"
6002	Ogee	3/8"	7/8"	1 5/8"
6003	Bead	3/8"	7/8"	1 5/8"
6004	Straight	3/8"	7/8"	1 5/8"
6005	Traditional	3/8"	7/8"	1 5/8"
6006	Classical	3/8"	7/8"	1 5/8"

For Individual Bits: Add A to Part Number for Stile Cutter.
Add B to Part Number for Rail Cutter.
Example: 6001A - Round Stile Cutter
Groover - 6625
Bearing - B5

Replacement Parts:

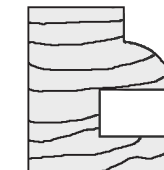

6001 - ROUND

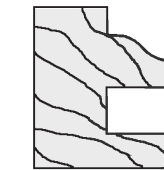

6002 - OGEE

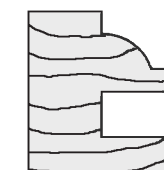

6003 - BEAD

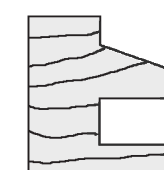

6004 - STRAIGHT

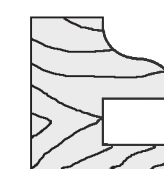

6005 - TRADITIONAL



6006 - CLASSICAL

PLYWOOD PANEL STILE & RAIL

This set-up is for cabinet door construction with undersized 1/4" plywood panels. (Actual panel thickness of 7/32" or 5.5 mm). Whiteside's **conversion kit #6000X** converts the regular full size Stile and Rail Bits to the narrower groove required for these plywood panels. This kit gives you the flexibility to do either plywood panels or raised panels. Plus, it can be used on any Whiteside full size Stile and Rail bits that you may already own.

Our two most popular Stile and Rail sets are also available ready to use just for plywood panel construction. Order Part Number **6001X** for round pattern or Part Number **6002X** for ogee pattern. 1/2" Shank only.



RAISED PANEL

MINIATURE RAISED PANEL BITS

1 3/4" Diameter - 1/2" Shank
Ball Bearing Guide

These raised panel bits offer a reduced pattern ideal for smaller projects. Available in your choice of cove or ogee profile shown below. To work with the miniature stile and rail bits, set bit depth to leave a 5/32" thick tongue. Leaves only a 3/8" panel reveal after assembly! Now you can use raised panel construction for small doors, chests, jewelry boxes, etc.

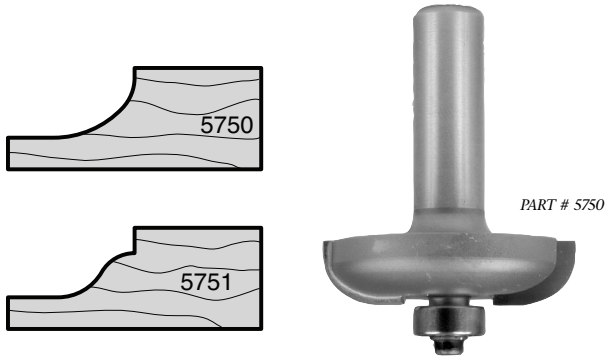

LARGE RAISED PANEL BITS

5900 Series - 2 wing - 3 1/4" Diameter
6000 Series - 3 wing - 3 3/8" Diameter
1/2" Shank - Ball Bearing Guide

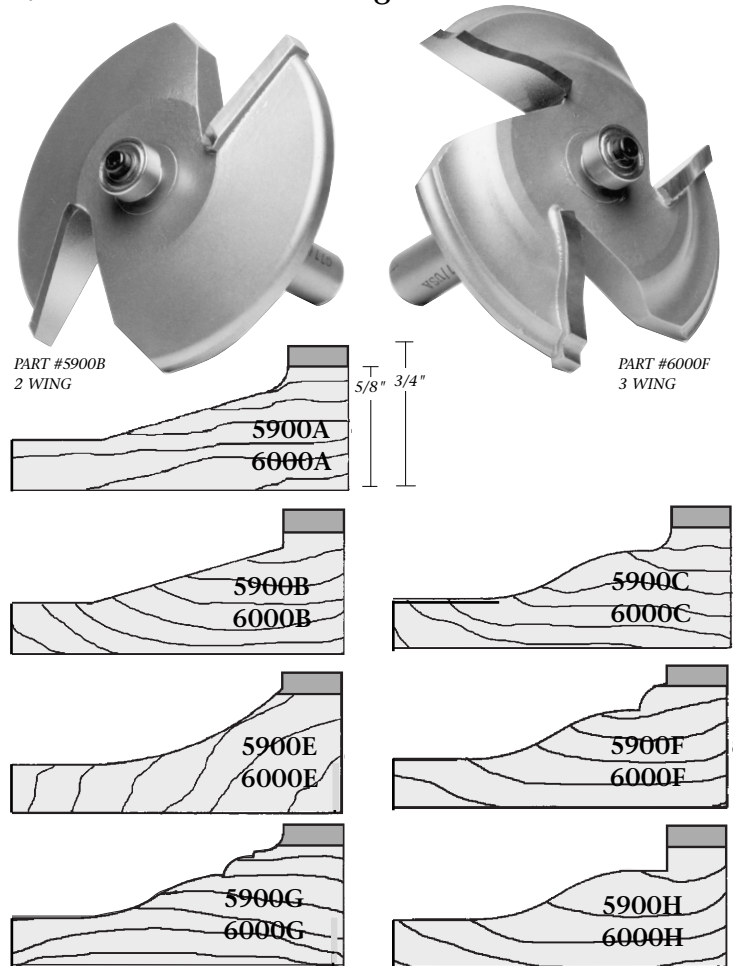

MEDIUM RAISED PANEL BITS

2 1/2" Diameter - 1/2" Shank
Ball Bearing Guide

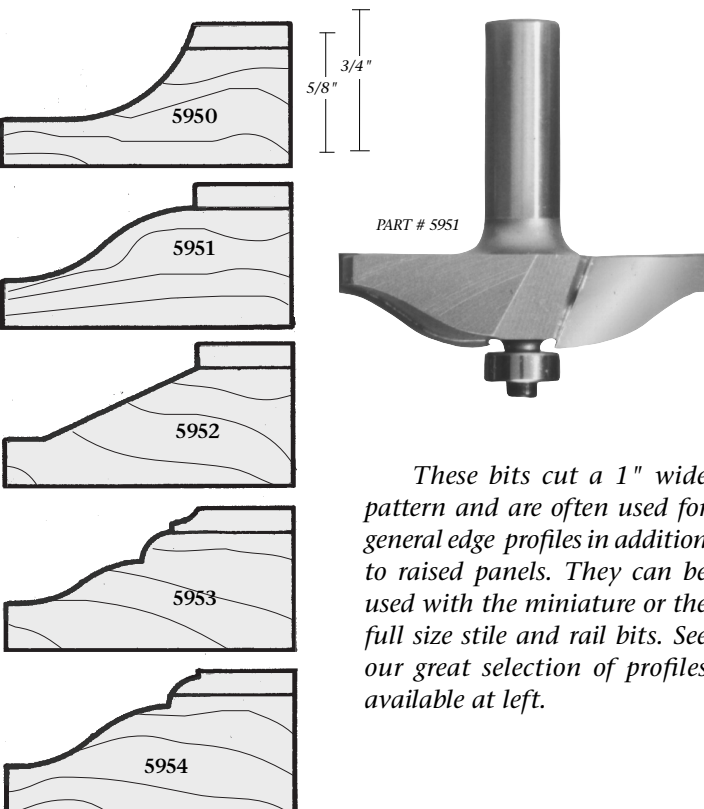

These bits cut a 1" wide pattern and are often used for general edge profiles in addition to raised panels. They can be used with the miniature or the full size stile and rail bits. See our great selection of profiles available at left.

LARGE RAISED PANEL BITS with BACK CUTTER

2 wing (2+2) - 3 1/4" Diameter
1/2" Shank - Ball Bearing Guide

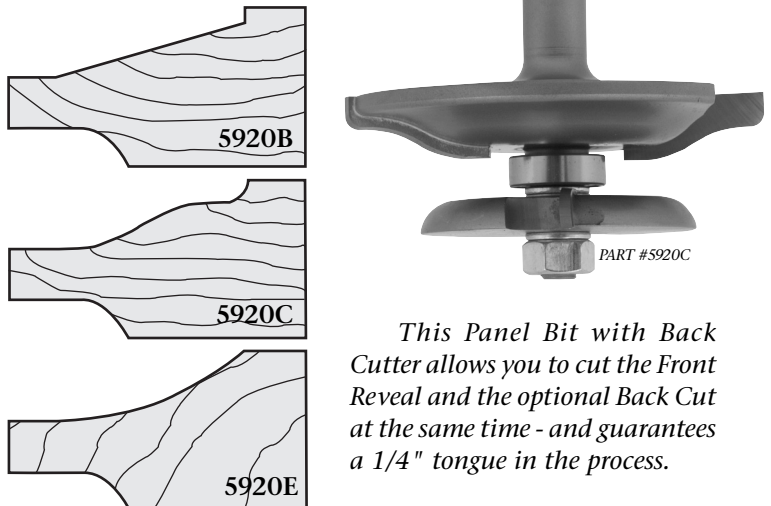

This Panel Bit with Back Cutter allows you to cut the Front Reveal and the optional Back Cut at the same time - and guarantees a 1/4" tongue in the process.



CABINET DOORS

RAISED PANEL DOOR CONSTRUCTION

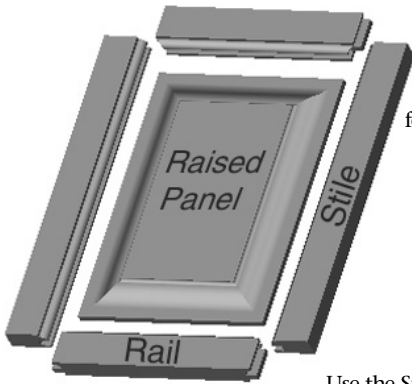

Choose stock size as appropriate for your project. For example, 3/4" x 2" stile & rails and 5/8" thick panels (without optional back cut) are common for cabinet doors. Use your stock size and door size to calculate the following:

- Stile length = Door height
- Rail length = Door width - width of both stiles + Interlock
- Panel height = Door height - width of both rails + Interlock - Expansion
- Panel width = Rail length - Expansion
- Interlock = 3/4" (3/8" per side) on Whiteside full size Stile & Rail bits or 1/2" (1/4" per side) for Whiteside miniature Stile & Rail.
- Expansion: Generally 1/8" on cabinet doors. Can vary with door size, green condition of wood, anticipated exposure to high humidity, and species of wood.

Use the Stile bit to cut the entire length of the inside edge on both the stiles and the rails.

Use the Rail bit to make the matching cross grain end cuts on the rails only.

Use the Raised Panel bit to cut all four sides of each raised panel face down on the router table. Set Raised Panel bit height for proper tongue thickness.

Tongue should be 1/4" for the full size Stile & Rail bits or 5/32" for the miniature ones. Allow extra stock if you plan to use the optional back cutter.

Use the Standard Glue Joint (page 22) or biscuits for added strength when gluing up larger panels.

Cut all components and test fit. Then glue up and reassemble. Glue only the stile and rail joints. The panel should be allowed to "float" to allow for expansion and contraction. You may choose to use anti-rattle snakes to prevent the panel from rattling. Make your own by running a 1/8" bead of 100% silicone caulk on wax paper. Allow to dry. Cut into pieces about 3/4" long. Insert in each groove at every corner while assembling. Check the door for squareness immediately after gluing up. It may also be helpful to pre-stain the raised panel because part of the concealed portion of the tongue may become visible later due to contraction. Complete the door by adding a door edge pattern (page 29) around the outside edge.

RAISED PANEL BACK CUTTER

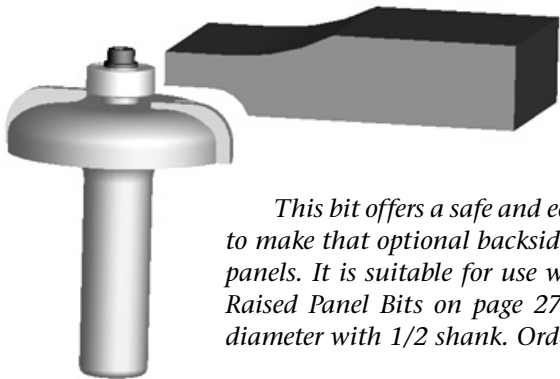

This bit offers a safe and economical way to make that optional backside cut on raised panels. It is suitable for use with any of our Raised Panel Bits on page 27. 1 3/4" large diameter with 1/2 shank. Order part #5850.

VERTICAL PANEL BITS

**1" Diameter - 1/2" Shank
1 1/2" Cut Length**

Vertical Panel Bits offer a method to cut full size raised panels with a smaller router bit requiring less horsepower. These bits are usually run in a router table with the panel standing on edge and the face of the panel against the fence. Fence must be tall enough to properly support the panel. Use on straight sided panels only since there is no bearing guide for arched or cathedral style doors.

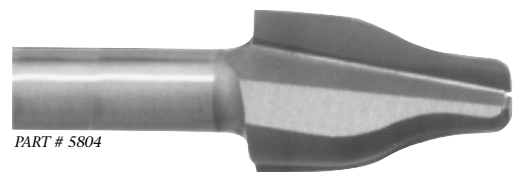

STILE & RAIL GLASS DOORS

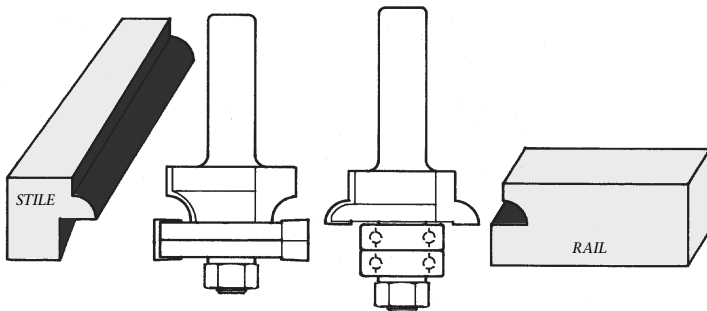

Make the Stile & Rail cuts for glass doors using Whiteside's full size Stile & Rail Sets on page 26. No extra components are required. All that's needed is to stagger the cutting edges and "stack" both groovers on the Stile bit. Use both bearings (no groover) on the Rail bit. See Drawing. Now make your cuts just like in normal door construction - Cut the inside edges of all four pieces with the Stile Bit. Trim the ends of the Rails with the Rail bit. Assemble door and insert glass pane. Use clips or corner trim mold on the back side to hold the pane in place.

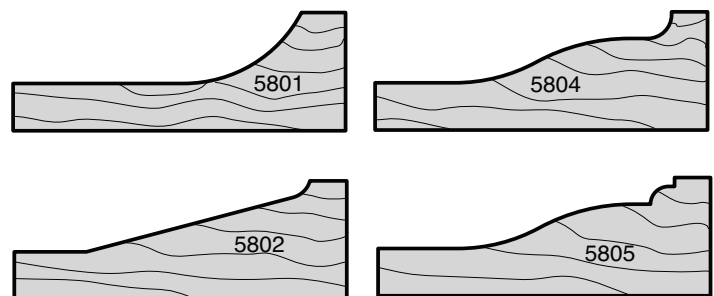



DOOR & DRAWER EDGE

DOOR EDGE BITS Complete Edge

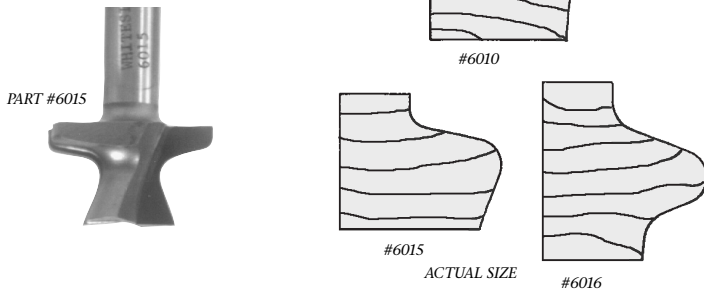

Part Number	Large Diameter	Cutting Length	Style
1/2" SHANK			
6010	1 3/8"	1 1/8"	Recessed Doors
6015	1 1/2"	7/8"	Finger Pull
6016	1 5/8"	15/16"	Reversible

DOOR EDGE BITS Front Face Edge Ball Bearing Guide

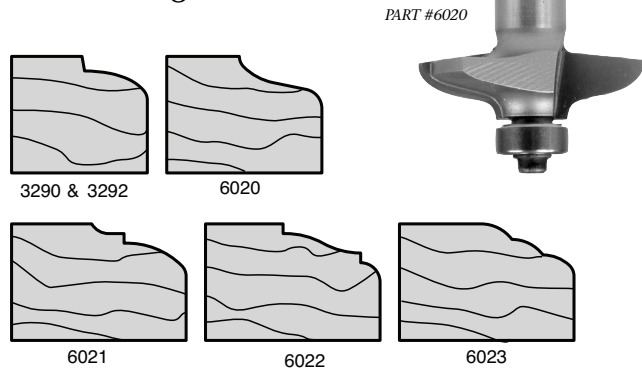

These bits cut a decorative profile along the front face of the door edge while leaving most of the edge straight. Their shallow design works well with concealed European style cup hinges. Many of our other edge profile bits (pg 18-19) also make great door edges. (Deeper profiles may not be compatible with European style cup hinges).

Part Number	Large Diameter	Cutting Length	Overall Length
1/4" SHANK			
3290	1 3/8"	3/8"	1 7/8"
1/2" SHANK			
3292	1 3/8"	3/8"	2"
6020	1 9/16"	3/8"	2 1/4"
6021	1 3/4"	3/8"	2 1/4"
6022	1 3/4"	3/8"	2 1/4"
6023	1 3/4"	3/8"	2 1/4"

DRAWER PULL - EUROPEAN STYLE

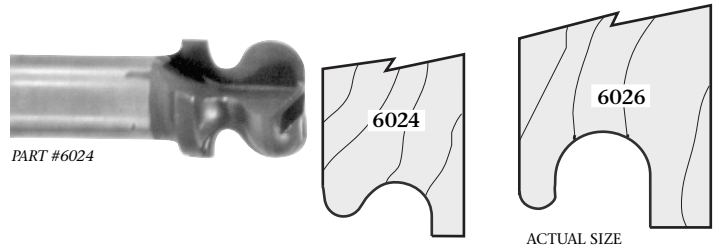

Part Number	Large Radius	Large Diameter	Cutting Length	Overall Length
1/2" SHANK				
6024	3/16"	3/4"	7/8"	2 3/8"
6026	1/4"	1 1/2"	13/16"	2 3/8"

DRAWER EDGE FINGER PULL

Produces a nice smooth finger grip primarily used on the bottom edge of drawer fronts. Also used as a finger pull on cabinet doors where no edge pattern is needed on the front face.



Part Number	Large Diameter	Cutting Length	Overall Length
1/2" SHANK			
6032	1 1/4"	3/4"	2 1/2"

Bearing Number: B3

WINDOW SILL EDGE/FINGER PULL

Originally designed to cut the front edge of window sills, this bit has also become popular for making a rounded finger edge on both drawers and door edges. Use with a router fence or add a shank mounted bearing for following a straight edge or template.

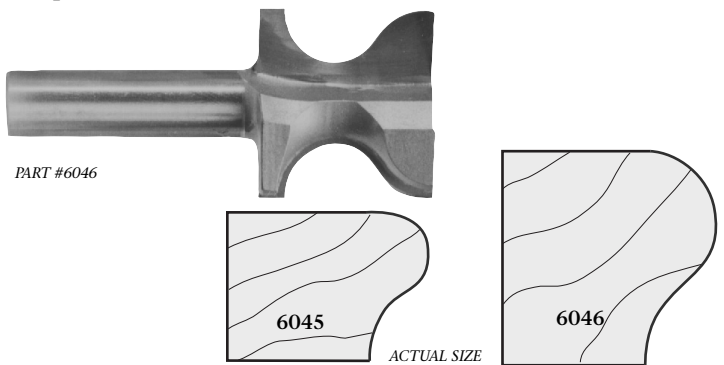

Part Number	Radius	Large Diameter	Profile Length	Overall Length
1/2" SHANK				
6045	7/32"	1 1/4"	13/16"	2 7/8"
6046	3/8"	1 7/16"	1 1/8"	3 3/8"

Use Bearing (B16 for #6045, B18 for #6046) and Lock Collar (LC-1/2) on Shank for Template Work.



WINDOW SASH · DOVETAIL SETS

WINDOW SASH

This is the only bit you need to make a complete window sash. The bearing guide controls the pattern depth and also allows you to make arched or curved windows and glass doors.

This assembly with the straight end cutter cuts the inside edges on both the stiles and rails. Convert the assembly to make the mating end cut by exchanging the straight cutter for the spacer (see drawing). The spacer can be installed between the profile cutter and the shank if additional reach across the workpiece is needed.) Now make the mating end cuts on the rails. This bit can also be used to cut both the decorative edges and the mating end cuts required to make your own window mullions (crosspieces).

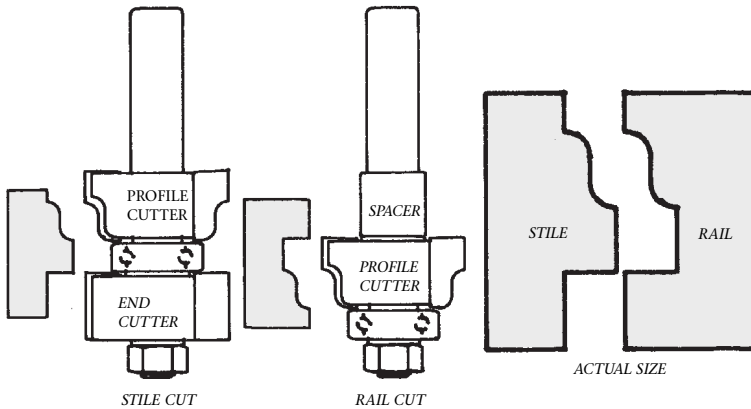
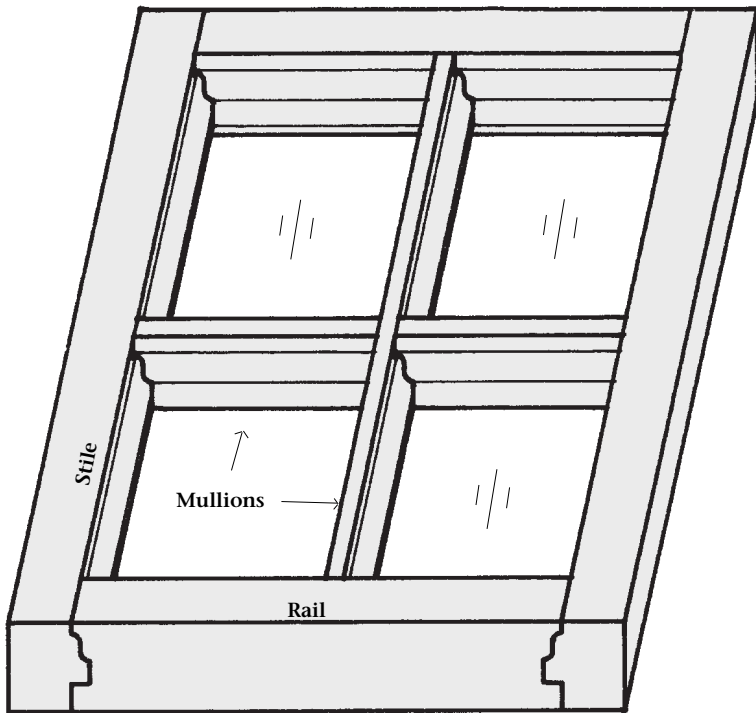

Part Number	Cutting Diameter	Cutting Length	Overall Length
6050	1 3/8"	7/8 - 1 5/8"	3 5/8"

Replacement Parts:
 Arbor: A380
 Bearing Number: B5
 Profile Cutter: 6050H
 Straight Cutter: 6050G
 Spacer: 6050SP

AKEDA DOVETAIL BITS



AKEDA
APPROVED

Whiteside offers USA quality bits made to Akeda's specifications for the Akeda Dovetail Jig. Available individually or in a complete set. All 1/4" Shank.

Part#	Description
Individual Bits	
DA7-438	Akeda 7° Dovetail Bit
DA9-438	Akeda 9° Dovetail Bit
DA11-438	Akeda 11° Dovetail Bit
DA14-438	Akeda 14° Dovetail Bit
DA20-438	Akeda 20° Dovetail Bit
1020 AKS	Akeda Standard Straight Bit
1020 AOS	Akeda Oversize Straight Bit
1020 AUS	Akeda Undersize Straight Bit
1020 ABJ	Akeda Box Joint Bit
Complete Set	
D102A	Akeda 9 pc. Set

INCRA DOVETAIL SETS

Top Quality Dovetailing Sets for use with the popular Incra System. Choose the #D101 Set (1/4" Shank) for the smaller Dovetails (1/4", 3/8", 1/2", 17/32"). Take the #605 Set (1/2" Shank) for the heavier 3/8", 1/2", 5/8", & 3/4" Dovetail bits. Both Sets also include the 1/4" and 3/8" Box Joint Bits.

Part#	Description
D101	6 Piece Incra Set - 1/4" Shank
605	6 Piece Incra Set - 1/2" Shank

All bits available individually. See next page.

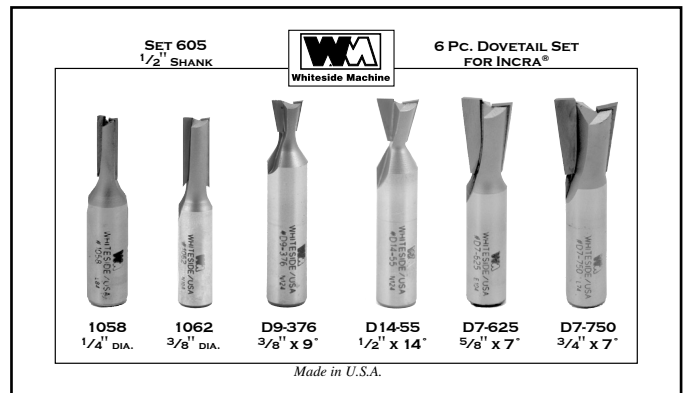

LEIGH DOVETAIL SETS

Upgrade to Whiteside Quality USA Bits for your Leigh jig. The smaller bits are supplied in the recommended 8mm Shanks (1/2" Adapter Collet is included). The largest sizes come in 1/2" shanks. Improved Performance Guaranteed.

Part#	Description
D108	7 Piece Leigh Set. Includes D8-437x8, D8-687, D14-51x8, D18-50x8, 1020x8, 1067, and 6400x8 Adapter.
D116	6 Piece Leigh Set for #D1600 16" Jig. All bits 8mm Shank. 6400x8 Adapter Collet to 1/2" is included. Complete with the following bits: 1020x8, D8-375x8, D8-500x8, D14-51x8, D18-50x8.

All bits available individually. See next page.



DOVETAIL BITS

DOVETAIL

BITS

Premium Quality
Dovetail Bits to meet
all your Dovetailing
Needs.

Part Number	Large Diameter	Depth Of Cut	Shank Diameter	Overall Length	Cross Reference
7° Angle					
D7-531	17/32"	3/4"	1/2"	2 1/2"	P·C #43776PC
D7-622	5/8"	7/8"	1/4"	2 3/8"	
D7-625	5/8"	7/8"	1/2"	2 5/8"	Incra™
D7-748	3/4"	7/8"	1/4"	2 3/8"	
D7-750	3/4"	7/8"	1/2"	2 5/8"	Incra™
*D7-875	7/8"	7/8"	1/2"	2 1/2"	Stair Tread
7 1/2° Angle					
^{sc} D75-25	1/4"	5/16"	1/4"	2 1/2"	Incra™/OmniJig® 43639
8° Angle					
^{sc} D8-250	1/4"	1/4"	1/4"	2 1/2"	Leigh #50
^{sc} D8-250x8	1/4"	1/4"	8mm	2 1/2"	Leigh #50-8mm shank
D8-312	5/16"	3/8"	1/4"	2 1/4"	Leigh #60
D8-312x8	5/16"	3/8"	8mm	2 1/4"	Leigh #60-8mm shank
D8-375	3/8"	1/2"	1/4"	2 3/8"	Leigh #70
D8-375x8	3/8"	1/2"	8mm	2 3/8"	Leigh #70-8mm shank
D8-437	7/16"	5/8"	1/4"	2 3/8"	Leigh #75
D8-437x8	7/16"	5/8"	8mm	2 3/8"	Leigh #75-8mm shank
D8-500	1/2"	13/16"	1/4"	2 3/4"	Leigh #80
D8-500x8	1/2"	13/16"	8mm	2 3/4"	Leigh #80-8mm shank
D8-687	11/16"	1"	1/2"	3"	Leigh #90
D8-812	13/16"	1 1/4"	1/2"	3 1/4"	Leigh # 100
9° Angle					
D9-312	5/16"	3/8"	1/4"	2 1/4"	Incra™
D9-372	3/8"	3/8"	1/4"	2"	Incra™
D9-373	3/8"	3/8"	3/8"	2"	
*D9-375	3/8"	3/8"	1/2"	2"	
*D9-376	3/8"	3/8"	1/2"	2 1/2"	Incra™
*D9-390	.390	3/8"	1/2"	2"	
10° Angle					
D10-50	1/2"	5/8"	1/4"	2 1/2"	Incra™/Leigh #101
D10-50x8	1/2"	5/8"	8mm	2 1/2"	Leigh #101-8mm shank
D10-55	1/2"	5/8"	1/2"	2 5/8"	Incra™
14° Angle					
D14-375	3/8"	3/8"	1/4"	2"	
D14-50	1/2"	1/2"	1/4"	2"	Incra™/OmniJig® #43705
D14-51	1/2"	1/2"	1/4"	2 3/8"	Leigh #120
D14-51x8	1/2"	1/2"	8mm	2 3/8"	Leigh #120-8mm shank
*D14-55	1/2"	1/2"	1/2"	2 1/2"	Incra™/OmniJig® #43750
D14-531	17/32"	1/2"	1/4"	2"	Incra™
D14-72	3/4"	3/4"	1/4"	2 3/8"	
D14-75	3/4"	3/4"	1/2"	3"	OmniJig® #43774
D14-100	1"	7/8"	1/2"	2 1/2"	
18° Angle					
D18-50	1/2"	3/8"	1/4"	2 1/4"	Leigh #128
D18-50x8	1/2"	3/8"	8mm	2 1/4"	Leigh #128-8mm shank
Straight Bits					
1020	5/16"	1"	1/4"	2 3/4"	Leigh #140
1020x8	5/16"	1"	8mm	2 3/4"	Leigh #140-8mm shank
1064A	13/32"	1"	1/2"	2 1/2"	P·C #43743PC
1065L	7/16"	1 1/4"	1/2"	3 1/4"	Leigh #150
1067	1/2"	1 1/4"	1/2"	2 7/8"	Leigh #160



*Also Stocked in Left Hand. Add LH to Part Number.

^{sc} - Solid Carbide

All bits designated Incra™ are also compatible with the JoinTech™ system

KELLER DOVETAIL BITS

Whiteside Machine Company offers precision router bits to match Keller's unique dovetailing system. All tools listed below are supplied with the required ball bearings.

Part Number	Keller Number	Large Diameter	Cutting Length	Shank Diameter	Overall Length
7° Angle Dovetail					
K31	1631	11/32"	3/8"	1/4"	2 1/4"
K33	1633	7/16"	3/4"	1/4"	2 5/8"
K35	2435	5/8"	1"	3/8"	2 5/8"
Straight Bits					
K41	1641	5/8"	1/2"	1/4"	2 1/4"
K43	1643/2443	5/8"	3/4"	1/4"	2 1/2"
3015	2445	7/8"	1"	3/8"	2 5/8"
*3032	1642	9/16"	3/4"	1/4"	2 1/4"

*Box Joint Bit

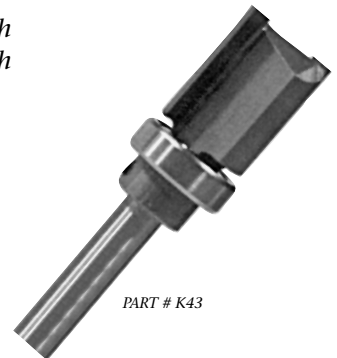
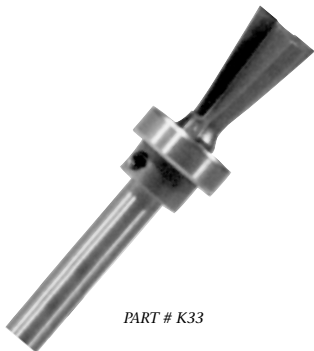



SPOILBOARD • SLOTTING

CNC SPOILBOARD SURFACING

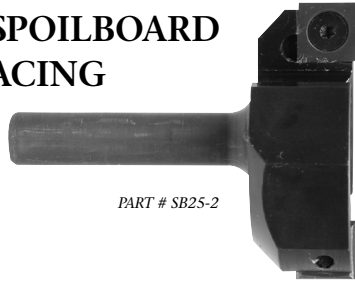

PART # SB25-2

Part Number	Large Diameter	Shank Size	# of Wings
STRAIGHT CUT			
SB25-2	2 1/2"	1/2"	2
SB40-2	4"	3/4"	2
SB40-3	4"	3/4"	3
UP SHEAR CUT			
SBU25-2	2 1/2"	1/2"	2
SBU40-3	4"	3/4"	3

CARBIDE INSERTS INDEXABLE - 4 CUTTING EDGES

Part Number	Description	Size
SB-Insert	10 Pc. Insert Pak	14 mm x 14mm x 2mm
SB Screw	Replacement Insert Screw	M5x7
SB Wrench	Insert Wrench	T-15 Torx

STEEL ROUTER COLLETS Reducer Bushings

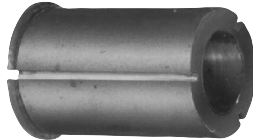

PART #6406

Part Number	I.D.	O.D.	Overall Length
6400	1/4"	1/2"	1 1/4"
6400x8	8mm	1/2"	1 1/4"
6401	5/16"	1/2"	1 1/4"
6402	3/8"	1/2"	1 1/4"
6403	1/4"	3/4"	1 1/4"
6404	5/16"	3/4"	1 1/4"
6405	3/8"	3/4"	1 1/4"
6406	1/2"	3/4"	1 1/4"

POLISHED SOLID CARBIDE KNIVES

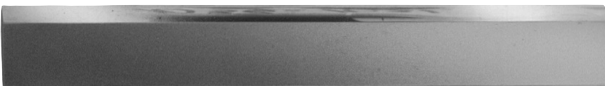

PART #6912

Part Number	Size
6902	1/8" x 5/8" x 4"
6904	1/8" x 5/8" x 6"
6906	1/8" x 5/8" x 8"
6910	1/8" x 3/4" x 4"
6912	1/8" x 3/4" x 6"
6914	1/8" x 3/4" x 8"

Sold Individually

SLOTTING CUTTERS 1 7/8" Cutting Diameter - 5/16" Bore



PART #6705A

Part Number		Kerf	
3 wing	4 wing	Decimal	Fractional
6700A	6700B	.062	1/16"
6701A		.070	---
6702A		.080	---
6703A	6703B	.094	3/32"
6704A		.100	---
6704C		.110	7/64"
6705A	6705B	.125	1/8"
6708A		.156	5/32"
6709A		.187	3/16"
6709C		.218	7/32"
6710A	6710B	.250	1/4"
6712A		.281	9/32"

Special Sizes Available Upon Request

SLOTTING CUTTER ARBORS

Includes B5 Bearing for 1/2" depth of cut.

Part Number	Shank Size	Overall Length
A200B	1/4"	2 3/8"
A205B	3/8"	2 3/8"
A210B	1/2"	2 3/8"
A220B	1/2"	4"

Note - A220B has an extra long shank for extended reach.

All include B5 Bearing for 1/2" depth of cut.

Use B20 Bearing for 9/16" depth of cut.

Use B25 Bearing for 3/8" depth of cut.

Use B26 Bearing for 1/4" depth of cut.

Use B27 Bearing for 5/8" depth of cut.

DRAWER SLOT CUTTERS (Jemco Machines)



PART #6800

Part Number	Cutting Diameter	Bore	Kerf	No. Flutes
6800	1 1/4"	3/8"-24thd	3/16"	4
6801	1 1/4"	3/8"-24thd	3/16"	6
6804	1 1/4"	3/8"-24thd	1/4"	4
6805	1 1/4"	3/8"-24thd	1/4"	6

DRAWER SLOT CUTTER ARBORS



PART #6891

Part Number	Shank Diameter	Overall Length	Thread
6890	1/4"	2"	3/8"-24
6891	3/8"	2"	3/8"-24
6892	1/2"	2"	3/8"-24
6896	3/8"	3 1/4"	3/8"-24

WM DOWEL DRILLS • BORING BITS

DOWEL DRILLS Carbide Tipped & Solid Carbide 10 mm Shank - Import

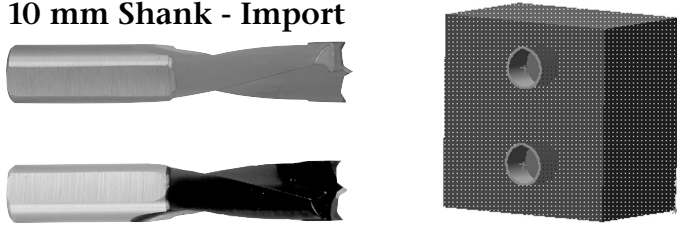

BRAD POINT (RH + LH)

Cutting Diameter	57mm OAL Part #	70mm OAL Part #
Inch	10 MM Shank - Inch Sizes	
3/16"	DB187-57 (LH)	DB187-70 (LH)
7/32"	DB218-57 (LH)	DB218-70 (LH)
1/4"	DB250-57 (LH)	DB250-70 (LH)
3/8"		DB375-70 (LH)
7/16"		DB437-70 (LH)
1/2"		DB500-70 (LH)

MM	10 MM Shank - Metric Sizes	
*3	DB3-57 (LH) SC	DB3-70 (LH) SC
4	DB4-57 (LH) (SC)	DB4-70 (LH) (SC)
5	DB5-57 (LH) (SC)	DB5-70 (LH) (SC)
6	DB6-57 (LH) (SC)	DB6-70 (LH) (SC)
7	DB7-57 (LH)	DB7-70 (LH)
8	DB8-57 (LH) (SC)	DB8-70 (LH) (SC)
9	DB9-57 (LH)	DB9-70 (LH)
10	DB10-57 (LH)	DB10-70 (LH)
11	DB11-57 (LH)	DB11-70 (LH)
12	DB12-57 (LH)	DB12-70 (LH)
13	DB13-57 (LH)	DB13-70 (LH)
14	DB14-57 (LH)	DB14-70 (LH)
15	DB15-57 (LH)	DB15-70 (LH)
16	DB16-57 (LH)	DB16-70 (LH)

RH and LH rotation. Include LH suffix for left hand rotation. Supplied with flat on shank.

Include SC suffix for optional Solid Carbide as available. *3 mm available in Solid Carbide only.



THRU HOLE V-POINT (RH + LH)

Cutting Diameter	57mm OAL Part #	70mm OAL Part #
Inch	10 MM Shank - Inch Sizes	
3/16"		DT187-70 (LH)
7/32"		DT218-70 (LH)
1/4"	DT250-57 (LH)	DT250-70 (LH)
3/8"		DT375-70 (LH)
7/16"		DT437-70 (LH)
1/2"		DT500-70 (LH)

MM	10 MM Shank - Metric Sizes	
*3	DT3-57 (LH) SC	DT3-70 (LH) SC
4	DT4-57 (LH) (SC)	DT4-70 (LH) (SC)
5	DT5-57 (LH) (SC)	DT5-70 (LH) (SC)
6	DT6-57 (LH) (SC)	DT6-70 (LH) (SC)
7	DT7-57 (LH)	DT7-70 (LH)
8	DT8-57 (LH) (SC)	DT8-70 (LH) (SC)
9	DT9-57 (LH)	DT9-70 (LH)
10	DT10-57 (LH)	DT10-70 (LH)
11	DT11-57 (LH)	DT11-70 (LH)
12	DT12-57 (LH)	DT12-70 (LH)
13	DT13-57 (LH)	DT13-70 (LH)
14	DT14-57 (LH)	DT14-70 (LH)
15	DT15-57 (LH)	DT15-70 (LH)

RH and LH rotation. Include LH suffix for left hand rotation. Supplied with flat on shank.

Include SC suffix for optional Solid Carbide as available. *3 mm available in Solid Carbide only.

HINGE BORING BITS Carbide Tipped 10 mm Shank - Import

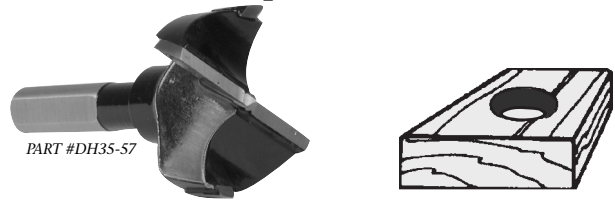

Cutting Diameter	57mm OAL Part #	70mm OAL Part #
MM	10 MM Shank	
15	DH 15-57 (LH)	DH 15-70 (LH)
20	DH 20-57 (LH)	DH 20-70 (LH)
25	DH 25-57 (LH)	DH 25-70 (LH)
30	DH 30-57 (LH)	DH 30-70 (LH)
35	DH 35-57 (LH)	DH 35-70 (LH)

RH and LH rotation. Include LH suffix for left hand rotation. Supplied with flat on shank.

WHITESIDE BORING BITS

Whiteside Machine Company's Carbide Tipped Boring Bits feature a centering point and two carbide spurs to eliminate tear out. The 2 1/8" diameter bit is used mostly for door knob holes. The 35mm diameter bit is widely used for European style cabinet door hinges. Made in USA.

*** Use in drill press or boring machine. NOT for use in routers.



Part Number	Cutting Diameter	Shank Diameter	Overall Length
6100	2 1/8"	1/2"	6 1/8"
6140	35mm	3/8"	2 3/8"

** Use only in drill press or boring machine.

FACE FRAME COUNTERBORES Carbide Tipped

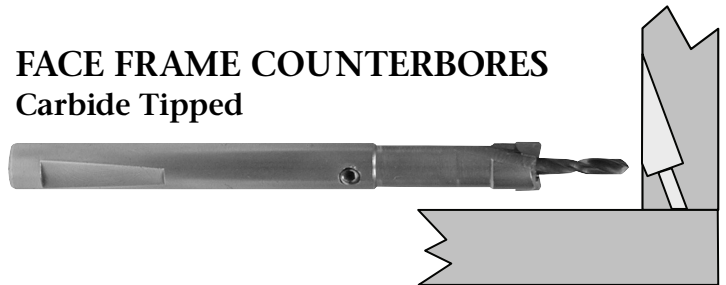

Part Number	Counterbore Diameter	Pilot Diameter	Length	Type
3/8" SHANK				
FF301	3/8"	.136	4"	Standard
FF301SP	3/8"	.136	4"	Spiral Flute
FF302	3/8"	.136	6"	Long
FF303	Replacement	.136 Pilot	Fishtail Drill Bit (HSS)	
FF304	Replacement	Set Screw	Uses 5/64 Hex Key	

Standard Type fits Unique, Norfield, Evans, Ritter, and Marcon face frame boring machines.

Long Version is for use on drill press.



ACCESSORIES

9500 - SOLID BRASS INLAY KIT

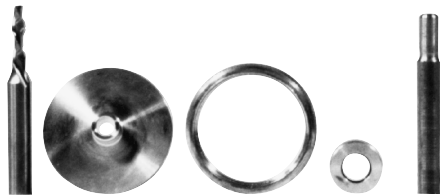

Whiteside's brass inlay kit allows you to make perfect fitting inlays for decoration or repairs. Simply cut your template from 1/4" thick material and trace it with your router to cut both the cavity in your workpiece and the matching inlay to be inserted. Instructions are included. Our kit includes a special centering pin to insure exact alignment with router spindle. Also includes a 1/8" Solid Carbide Spiral Router Bit (Part# RD1600).

9510 - BASE PLATE REDUCERS - SOLID BRASS

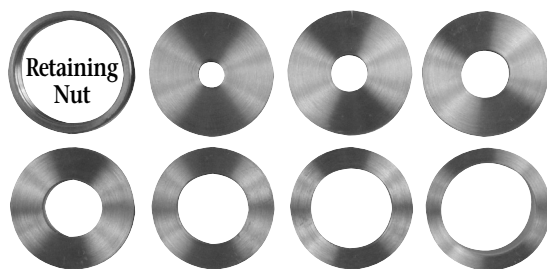

These solid brass inserts fit into your router base plate to reduce the gap around the router bit. Not only is this safer, but it also reduces tearout and helps support smaller workpieces. Supplied in a set with openings of 1/4", 3/8", 1/2", 5/8", 3/4", 7/8", and 1", plus retaining nut. Openings are slightly oversize for tool clearance. Fits any router with a standard 1 3/16" diameter recessed hole for template guides.

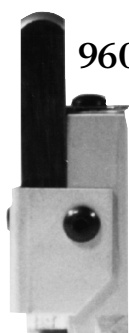

9600 - SQUARE CORNER CHISEL

Use this tool to square up the round corners left behind when routing hinge mortises. Hold unit in mortise corner and strike with hammer. Our chisel features a sharp 3/8" square hardened steel cutting blade. Made in USA by Whiteside Machine Company.



QUICK CHANGE CHUCKS

Swap router bits quickly and easily. Cam-lock design clamps and loosens with a partial turn using a hex key wrench. Much simpler than the original two wrench method. Holds 1/2" shank bits. Order #6400 Router Collet for 1/4" shanks. Replace the factory collet with a Quick Change.

Part Number	Description
9700	All 1/2" Porter-Cable (except #100)
9710	All 1/2" Bosch
9720	Dewalt 625/Elu 1/2" /Fein/Festool/Freud
9730	Dewalt 616, 618, 621

9750 - EXTENSION ADAPTER For CNC Carving Machines

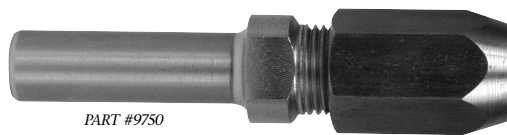

Used for light routing and veining on CNC carving machines. Allows deeper reach. Adapter is 1/2" shank. Accepts 1/4" shank bits only. Order Part #9750.

BRASS SET-UP GAUGE BLOCKS

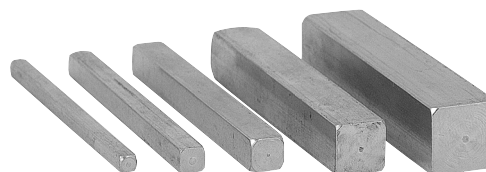

Our Square Gauge Blocks are a quick way to make many easy, accurate set-ups. A great way to make exact depth movements on plunge routers. On table routers, they're perfect for setting distances from the fence to the cutter, or for checking the bit height above the table. Supplied in 1/8", 3/16", 1/4", 3/8", and 1/2" squares. Blocks can be "stacked" to cover a wider range of sizes. A very helpful tool!

Part#	Description
9800	5 pc. Set - 2 1/2" Long
9810	5 pc. Set - 4" Long

ARBORS

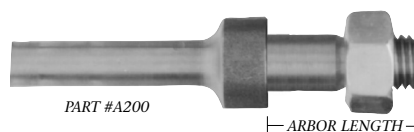

Part Number	Shank Diameter	Arbor Diameter	Arbor Length	Overall Length
A200	1/4"	5/16"	7/8"	2 3/8"
A205	3/8"	5/16"	7/8"	2 1/2"
A210	1/2"	5/16"	7/8"	2 5/8"
A220	1/2"	5/16"	7/8"	4"
A250	1/4"	5/16"	1 3/16"	2 3/4"
A260	1/2"	5/16"	1 3/16"	2 7/8"
A300	1/4"	5/16"	1 7/16"	3"
A310	1/2"	5/16"	1 7/16"	3 3/16"
A375	1/2"	5/16"	1 3/4"	3 3/8"
A550	1/2"	1/2"	1 7/8"	3 7/8"
A560	1/2"	1/2"	2 3/8"	4 3/8"

Arbors include nut and washer.

W300 - SHIM WASHER KIT

Use these shim washers to fine adjust the spacing on any arbor or assembly with a 5/16" diameter arbor (Slot Cutters, Stile & Rail, Window Sash, Tongue & Groove). Washers are 5/16" I.D. x 1/2" O.D. Includes three each of the following thicknesses: .004, .006, .008, .010, .012.



BEARINGS

BALL BEARINGS



PART #B5

Part Number	Outside Diameter	Inside Diameter	Application
B1A	1/4"	1/8"	
B1	3/8"	1/8"	
B2	3/8"	3/16"	
B3	1/2"	3/16"	Standard
B3BLK	1/2"	3/16"	100 pcs. bulk
B3S	1/2"	3/16"	Non-Mar Nylon Sleeve
B3SQ	1/2"	3/16"	Euro-Square (Pg. 15)
B3T	1/2"	3/16"	Teflon® Shields
B3U	.490"	3/16"	for resharps (undersize)
B4	3/4"	1/4"	
B5	7/8"	5/16"	
B6	5/8"	1/4"	
B7	5/8"	3/16"	
B8	3/4"	3/16"	
B8SQ	3/4"	3/16"	Euro-Square (Pg. 15)
B9	1/2"	1/4"	
B9U	.490"	1/4"	for resharps (undersize)
B11	1 1/8"	1/2"	
B12	7/8"	3/8"	
B13	7/8"	1/2"	
B14	11/16"	3/16"	
B15	13/16"	3/16"	
B16	1 1/4"	1/2"	
B17	1 3/8"	1/2"	
B18	1 1/2"	1/2"	
B19	3/4"	1/2"	
B20	3/4"	5/16"	
B21	7/8"	1/4"	
B24	1 7/8"	1/2"	
B25	1 1/8"	5/16"	
B26	1 3/8"	5/16"	
B27	5/8"	5/16"	
B28	7/8"	3/16"	
B29	1"	3/16"	
B33	9/16"	3/16"	
BB300	7/8" x 10°	3/16"	Non-Mar Nylon Sleeve

BB501 - 5 PIECE BEARING CONVERSION KIT

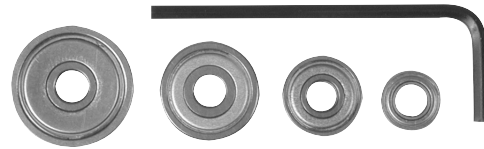

Use this kit to vary the horizontal cutting depth of router bits with bearing pilots.

Great for stepping in to finish depth by controlled increments.

Contains B2 (3/8"), B3 (1/2"), B7 (5/8"), B8 (3/4") Bearings and 3/32" Hex Key Wrench

BB600 - GENERAL BEARING REPAIR KIT

This handy kit includes spare bearings, screws, and wrench to replace bearings on most bits.

Includes five B3 (1/2 x 3/16) and two B2 (3/8 x 3/16) bearings, ten 54025S Screws, and a 3/32 Hex Key Wrench.

BB701 - ACCESSORY KIT

Great for replacement bearings and screws - Plus this generous bearing assortment allows you to vary your cutting depths and change your profiles. Also contains lock collars and bearings for adding bearing guides to the shanks of your standard bits for following templates.

Contains: 12 bearings — four B3 (1/2 x 3/16), one each of B2 (3/8 x 3/16), B7 (5/8 x 3/16), B8 (3/4 x 3/16), B9 (1/2 x 1/4), B6 (5/8 x 1/4), B4 (3/4 x 1/4), B5 (7/8 x 5/16) and B11 (1 1/8 x 1/2); two each 1/4" lock collars (LC-1/4) and 1/2" lock collars (LC-1/2); one each 1/16, 5/64, 3/32 and 5/32 Hex Key wrenches; plus ten 54025S bearing screws.

BEARING LOCK COLLARS

Retaining Collars used when bearings are added to the shanks of router bits for following templates.

Part Number	Shank Diameter	Outside Diameter
LC-1/4	1/4"	7/16"
LC-1/2	1/2"	11/16"

Uses part # HK-1/16 Hex Key Wrench
#LCS-Replacement Set Screw for Lock Collars



HEX KEY WRENCHES

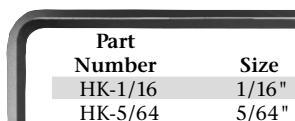

Part Number	Size	Application
HK-1/16	1/16"	Bearing Lock Collars
HK-5/64	5/64"	1/8" I.D. Bearings (3-48 Screw)
* HK-3/32	3/32"	3/16" I.D. Bearings (5-40 Screw)
HK-5/32	5/32"	1/4" I.D. Bearings (10-32 Screw)

* Standard Size for Most Bits

SPARE PARTS LISTING



Socket Head Cap Screws - 10 pc. pack

Part Number	Thread Size	Thread Length	Hex Key Size
34825S	3-48	1/4"	5/64"
54025S	5-40	1/4"	3/32"
103238S	10-32	3/8"	5/32"

Add BLK to part number for 100 pcs.

Flat Washers - 10 pc. pack

Part Number	Inside Diameter	Outside Diameter	Thickness
31250W	5/16"	1/2"	1/16"

Hex Nuts - 10 pc. pack

Part Number	Thread Size	Width	Hex Size
1032N	10-32	1/4"	3/8"
31224N	5/16-24	1/4"	1/2"

Replacement Parts By Tool Number

Replacement Bearing sizes are listed in the catalog with each tool. Most tools with bearing pilots on the end require only the 54025S Screw. Exceptions:

34825S Screw:	2400,2401,2404A
103238S Screw	2013-2016, 2410, 2415, 2560, 2570, 2575, 2580, 2715, 2900-2908, 3390
1032N Nut	RFT5125, RFTD5125, RFT5200 RFTD5200, UDFT5152



WHITESIDE
MACHINE CO.

Router Bit Sets

Durable Plastic Cases!
Keep Your Tools Safe
and Organized.

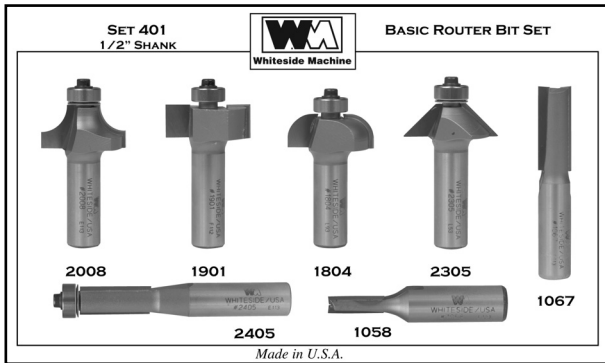

Set 401 - BASIC 7 Pc. Bit Set - 1/2" Shank

Set 402 - BASIC 7 Pc. Bit Set - 1/4" Shank

This is the set pictured on the back cover. It's made up of only the most popular woodworking bits. Includes our 1/4" Straight, 1/2" Straight, R3/8 Roundover, 3/8" x 1/2" Rabbet, R3/8 Cove, 45° Chamfer, and 1/2" Flush Trim. All USA Quality.

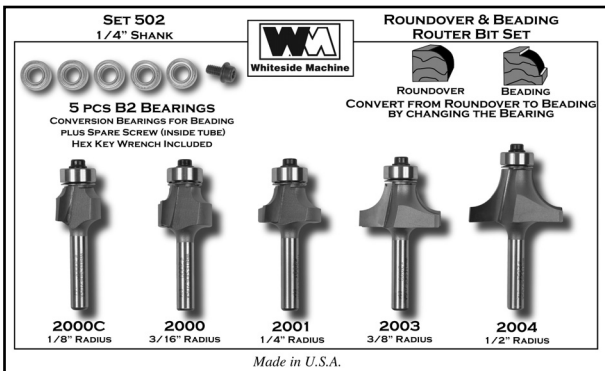

Set 502 - ROUNDROVER & BEADING - 1/4" Shank

Easily round off all your square edges with lightweight 1/4" capacity Hand Routers. Keep the whole range of sizes (R1/8, R3/16, R1/4, R3/8, R1/2) neatly organized and right at your fingertips. As with the 1/2" shank set, this kit comes fully equipped to extend its usage by converting to Beading - i.e., Roundover with a decorative step.

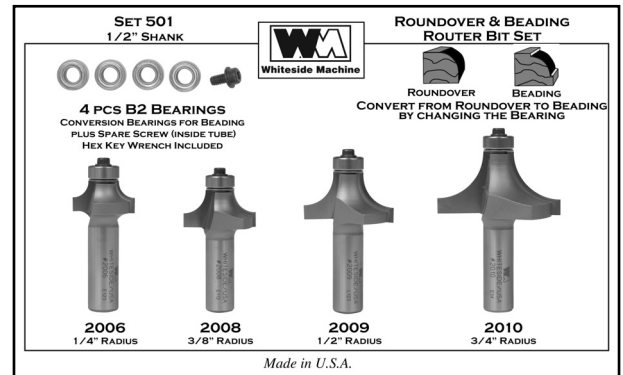

Set 501 - ROUNDROVER & BEADING - 1/2" Shank

Roundovers are by far the most used Edge forming bits in woodworking. This set offers the most common Radii (R1/4, R3/8, R1/2) in 1/2" shanks, plus a hefty 3/4" Radius workhorse. Extra bearings and wrench are included to convert each bit from Rounding over to Beading - i.e., Roundover with a decorative step.



Set 600 - STRAIGHT & HALF ROUND COMBO - 1/2" Shank

A nice collection of Straight Bits and Half Rounds grouped together in one protective case. This set includes:

- 3/8 Straight
- 1/2 Straight
- 5/8 Straight
- 3/4 Straight
- 3/8 Half Round
- 1/2 Half Round
- 5/8 Half Round
- 3/4 Half Round

This handy group covers the full assortment of bits needed for the INCRA® HingeCrafter. Whiteside Industrial Quality.

Also See Our Dovetail Sets on Page 30.