



**Valli&Valli**

**CATALOGO / CATALOGUE 2009**

**Legenda Codici  
di Identificazione Articoli**  
Articles Identification Codes  
**pag. 2**

---

**COLLEZIONE V&V**  
V&V COLLECTION

---

**Maniglie per Porta**  
Door Handles  
**pag. 6**

**Maniglie per Finestra**  
Window Handles  
**pag. 102**

**Pomoli per Porta**  
Door Knobs  
**pag. 124**

**Maniglioni**  
Pull Handles  
**pag. 129**

**Bocchette**  
Escutcheons  
**pag. 136**

**Placche**  
Plates  
**pag. 145**

**Maniglie per Incasso**  
Inset Handles  
**pag. 147**

**Chiusure Privacy BZG**  
Bathroom Privacy Sets  
**pag. 158**

**Copridadi**  
Nut Covers  
**pag. 160**

**Fermaporta**  
Door Stops  
**pag. 161**

**Battiporta**  
Door Knockers  
**pag. 162**

**Chiavi per Porta**  
Door Keys  
**pag. 163**

**Copriavvolgitori**  
Coiler Covers for Venetian Blinds  
**pag. 167**

**Reggimensola**  
Shelfbrackets  
**pag. 169**

**Ganci**  
Hooks  
**pag. 170**

**Portabiti**  
Coathooks  
**pag. 171**

**Coprinterruttori**  
Switch-covers  
**pag. 178**

**Appendiquadri**  
Picture Hooks  
**pag. 181**

**Ganci per Tende**  
Curtain Hooks  
**pag. 181**

**Programma Desipro**  
Desipro Programme  
**pag. 183**

**Complementari  
e Sistemi di Fissaggio**  
Complementary Accessories  
and Fixing Systems  
**pag. 291**

---

**COLLEZIONE V&V  
ACCIAIO INOX**  
V&V STAINLESS STEEL  
COLLECTION

---

**Maniglie per Porta**  
Door Handles  
**pag. 201**

**Maniglie per Finestra**  
Window Handles  
**pag. 216**

**Pomoli per Porta**  
Door Knobs  
**pag. 220**

**Maniglioni**  
Pull Handles  
**pag. 224**

**Fermaporta**  
Door Stops  
**pag. 226**

**Bocchette**  
Escutcheons  
**pag. 227**

**Chiusure Privacy BZG**  
Bathroom Privacy Sets  
**pag. 228**

**Complementari  
e Sistemi di Fissaggio**  
Complementary Accessories  
and Fixing Systems  
**pag. 311**

---

**COLLEZIONE V&V  
ACCESSORI DEL MOBILE**  
V&V CABINET HARDWARE  
COLLECTION

---

**Maniglie**  
Handles  
**pag. 232**

**Pomoli**  
Doorknobs  
**pag. 270**

**Bocchette**  
Escutcheons  
**pag. 285**

**Chiavi**  
Keys  
**pag. 286**

**Cerniere**  
Hinges  
**pag. 288**

**Complementari  
e Sistemi di Fissaggio**  
Complementary Accessories  
and Fixing Systems  
**pag. 325**

---

**AVVERTENZE  
E CERTIFICAZIONI**  
INSTRUCTIONS  
AND CERTIFICATION

---

**Avvertenze**  
Instructions  
**pag. 330**

**Qualità**  
Quality  
**pag. 332**

**Trattamento Protettivo**  
Protective Coating  
**pag. 334**

**CONTATTI / CONTACT**  
**pag. 336**

---





## Legenda Codici di Identificazione Articoli Articles Identification Codes

Identificazione tipologia prodotto  
Product type identification

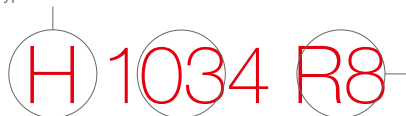

Numerazione articolo  
Article number

Parametri di identificazione articolo  
Article identification parameters

- A** **Maniglie da mobile** / Furniture handles
- B** **Pomoli da mobile** / Furniture knobs
- C** **Bocchette/chiavi da mobile** / Furniture escutcheons/keys
- H** **Maniglie per porta e per finestra** / Door handles and window handles
- K** **Pomoli per porta** / Door knobs  
**Maniglioni** / Pull handles  
**Bocchette** / Escutcheons  
**Placche** / Plates  
**Maniglie per incasso** / Inset handles  
**Chiusure privacy BZG** / Bathroom privacy sets  
**Copridadi** / Nut covers
- L** **Fermaporta** / Door stops  
**Battiporta** / Door knockers
- M** **Chiavi per porta** / Door keys
- N** **Copriavvolgitori** / Coiler covers for venetian blinds
- E** **Portabiti** / Coat hooks  
**Ganci** / Hooks  
**Reggimensola** / Shelf brackets
- F** **Coprinterruttori** / Switch-covers
- G** **Appendiquadri** / Picture hooks
- X** **Complementari e sistemi di fissaggio** / Complementary accessories and fixing systems



**R8** **Articolo con rosetta, quadro  $\square$  8mm, bocchetta con foro chiave normale**

Article on rosette,  $\square$  8mm spindle, with standard escutcheon



**R8 Y** **Articolo con rosetta, quadro  $\square$  8mm, bocchetta con foro chiave cilindro**

Article on rosette,  $\square$  8 mm spindle, with cylinder escutcheon



**P8 90\*** **Articolo con placca, quadro  $\square$  8mm, foro chiave normale, interasse tra foro maniglia e foro chiave in mm**

Article on plate,  $\square$  8 mm spindle, standard key hole, with distance between handle hole and key hole centre in mm



**P8 Y 85\*** **Articolo con placca, quadro  $\square$  8 mm, foro chiave cilindro e interasse tra foro maniglia e foro chiave in mm**

Article on plate,  $\square$  8 mm spindle, cylinder key hole with distance between handle hole and key hole centre in mm



**F** **Maniglia per finestra**

Window handle



**F RS-41** **Maniglia per finestra con movimento DRY-KEEP 4 scatti e lunghezza del quadro in mm**

Window handle with DRY-KEEP movement, 4 click positions with spindle length in mm



**SB** **Articolo con rosetta senza bocchetta**

Article on rosette, without escutcheon



**Y** **Articolo con rosetta e bocchetta con foro chiave cilindro**

Article on rosette with cylinder escutcheon



**PY D 85\*** **Articolo con placca, per foro chiave cilindro, versione destra e interasse tra foro maniglia e foro chiave in mm**

Article on plate, for cylinder key hole, right hand version with distance between handle hole and key hole centre in mm



**PY S 85\*** **Articolo con placca, per foro chiave cilindro, versione sinistra e interasse tra foro maniglia e foro chiave in mm**

Article on plate, for cylinder key hole, left hand version with distance between handle hole and key hole centre in mm



**PL 90\*** **Placca stretta con interasse tra foro maniglia e foro chiave in mm**

Narrow plate with distance between handle hole and key hole centre in mm



**PL Y 85\*** **Placca stretta con foro chiave cilindro, interasse tra foro maniglia e foro chiave in mm**

Narrow plate with cylinder key hole, with distance between handle hole and key hole centre in mm



**RS** **Rosetta stretta**

Narrow rosette



**SFC** **Articolo senza foro chiave**

Article without key hole

**R 6-7-8 BZG-85**

**Chiusura privacy, quadro  $\square$  mm 6-7-8 e lunghezza mm 85**

Bathroom privacy set,  $\square$  6-7-8 mm diameter spindle with length of 85 mm

**RS 6-7-8 BZG-85**

**Chiusura privacy con indicatore libero/occupato,  $\square$  quadro mm 6-7-8 e lunghezza mm 85**

Bathroom privacy set with free/occupied indicator,  $\square$  6-7-8 mm diameter spindle with length of 85 mm



V&V

Collezione V&V  
V&V Collection



## Maniglie per Porta Door Handles



**H 1048** Serie Orione  
design Ludovica +  
Roberto Palomba  
**pag. 8**



**H 1047** Serie Zaide  
design Emanuela Frattini  
**pag. 10**



**H 1046** Serie Nais  
design Valli Workshop  
**pag. 12**



**H 1045** Serie Bess  
design Yoshimi Kono  
**pag. 14**



**H 1044** Serie Oberon  
design Vincent Van Duysen  
**pag. 16**



**H 1043** Serie Alcina  
design Matteo Thun  
**pag. 18**



**H 1042** Serie Walkiria  
design Panacom Achitects/  
Arseniy Leonovich  
**pag. 20**



**H 1041** Serie Porgy  
design Yoshimi Kono  
**pag. 22**



**H 1040** Serie Siberia  
design Gabriele  
e Oscar Buratti  
**pag. 24**



**H 1039** Serie Fedra  
design Jean-Baptiste  
Sibertin Blanc  
**pag. 26**



**H 1038** Serie Armida  
design Decoma Design  
**pag. 28**



**H 1037** Serie Teseo  
design Valli Workshop  
**pag. 30**



**H 1036** Serie Amin  
design Valli Workshop  
**pag. 32**



**H 123** Serie Luigi XVI  
design Valli Workshop  
**pag. 34**



**H 120** Serie Luigi XV  
design Valli Workshop  
**pag. 36**



**H 1034** Serie Polis  
design Decoma Design  
**pag. 38**



**H 1032** Serie Capriccio  
design Gensler Associates  
International  
**pag. 40**



**H 1030** Serie Elisir  
design Sergio Asti  
**pag. 42**



**H 1027** Serie Dafne  
design Studio Carlesi Design  
**pag. 44**



**H 1026** Serie Dido  
design Antonio Bullo  
**pag. 46**



**H 1024** Serie Lolita  
design Valli Workshop  
**pag. 48**



**H 1022** Serie Ernani  
design Valli Workshop  
**pag. 50**



**H 1018** Serie Otello  
design Marius Schreyer Design  
**pag. 52**



**H 1017** Serie Camelia  
design Matteo Thun  
**pag. 54**



**H 1016** Serie Nabucco  
design Valli Workshop  
**pag. 56**



**H 1015** Serie West  
design Itamar Harari  
**pag. 58**



**H 1013** Serie Mosè  
design Valli Workshop  
**pag. 60**



**H 1012** Serie Poliuto  
design Valli Workshop  
**pag. 62**



**H 1010** Serie Medea  
design Valli Workshop  
**pag. 64**



**H 1004** Serie Antares  
design Valli Workshop  
**pag. 66**



**H 1003** Serie Croco  
design Matteo Thun  
**pag. 68**



**H 1000** Serie Angelica  
design Valli Workshop  
**pag. 70**



**H 914/8** Serie Medicea  
design Pasquale Valli  
**pag. 72**



**H 227** Serie Rigel  
design Valli Workshop  
**pag. 74**



**H 198** Serie Mizar  
design Eero Aarnio  
**pag. 76**



**H 196** Serie Ulisse L  
design Cozza e Mascheroni  
**pag. 78**



**H 195** Serie Orchidea  
design Valli Workshop  
**pag. 80**



**H 192** Serie Prunus  
design Valli Workshop  
**pag. 82**



**H 179** Serie Aida  
design Matteo Thun  
**pag. 84**



**H 176** Serie Spiga  
design Valli Workshop  
**pag. 86**



**H 174** Serie Altair  
design Valli Workshop  
**pag. 88**



**H 165** Serie Germana  
design Valli Workshop  
**pag. 90**



**H 163** Serie Sarissa  
design Valli Workshop  
**pag. 92**





# H 1048

Serie ORIONE / design Ludovica + Roberto Palomba



▲  
**Cromo** / Chrome



**Cromsatin**  
Satin Chrome

## Coordinato Matching Elements

**H 1048 F**  
**H 1048 F RS**  
Pg. 102

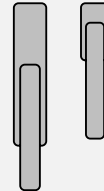

**K 1141**  
**K 1141 Y**  
Pg. 136



**K 1229 R6-7-8 BZG**  
Pg. 158



**Ottone** / Brass

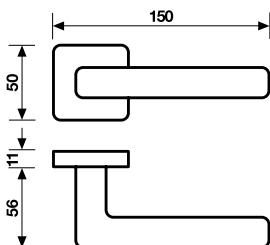

**H 1048 R8**  
**H 1048 R8 Y**



# H 1047

Serie ZAIDE / design Emanuela Frattini



▲  
**Oro Lucido** / Polished Brass



**Cromo**  
Chrome



**Cromsatin**  
Satin Chrome



**Anticato**  
Antique

**Ottone** / Brass

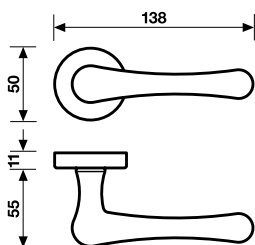

**H 1047 R8**  
**H 1047 R8 Y**

## Coordinato Matching Elements

**H 1047 F**  
**H 1047 F RS**  
Pg. 102

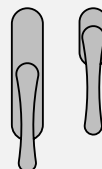

**K 1121**  
**K 1121 Y**  
Pg. 140





# H 1046

Serie NAIS / design Valli Workshop



▲  
**Cromsatin** / Satin Chrome



**Cromo**  
Chrome

## Coordinato Matching Elements

**H 1046 F**  
**H 1046 F RS**  
Pg. 103

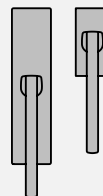

**K 1139**  
**K 1139 Y**  
Pg. 136



**Ottone** / Brass

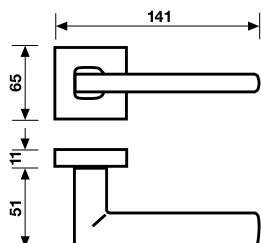

**H 1046 R8**  
**H 1046 R8 Y**



# H 1045

Serie BESS / design Yoshimi Kono



▲  
**Cromsatin/Cromo** / Satin Chrome/Chrome



**Cromo**  
Chrome



**Orolux**  
Brass Plated

**Nikrall Lega Zama UNI 3717** / Nikrall Zamak alloy UNI 3717

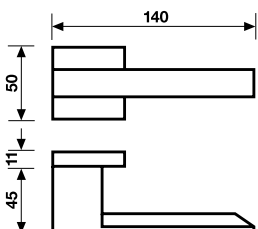

**H 1045 R8**  
**H 1045 R8 Y**

## Coordinato Matching Elements

**H 1045 F**  
**H 1045 F RS**  
Pg. 103

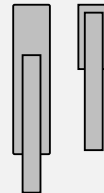

**K 1165**  
Pg. 124



**K 1138**  
**K 1138 Y**  
Pg. 136



**K 1228**  
Pg. 129  
**K 169**  
Pg. 134



**E 1025**  
**E 1024**  
Pg. 170-171

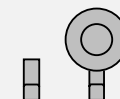

**K 1232**  
**K 1230**  
Pg. 147-148







# H 1044

Serie OBERON / design Vincent Van Duysen



▲  
**Cromsatin** / Satin Chrome



**Cromo**  
Chrome



**Orolux**  
Brass Plated

## Coordinato Matching Elements

**H 1044 F**  
**H 1044 F RS**  
Pg.104

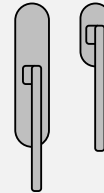

**K 1121**  
**K 1121 Y**  
Pg. 140



**Nikrall Lega Zama UNI 3717** / Nikrall Zamak alloy UNI 3717

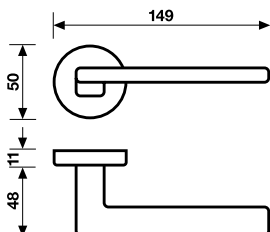

**H 1044 R8**  
**H 1044 R8 Y**



# H 1043

Serie ALCINA / design Matteo Thun



▲  
**Cromo/Cromsatin** / Chrome/Satin Chrome



**Orolux/Orsatin**  
Brass Plated/Satin Brass

## Coordinato Matching Elements

**H 1043 F**  
**H 1043 F RS**  
Pg. 104

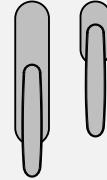

**K 1112**  
**K 1112 Y**  
Pg. 140



**Nikrall Lega Zama UNI 3717** / Nikrall Zamak alloy UNI 3717

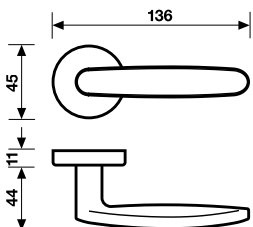

**H 1043 R8**  
**H 1043 R8 Y**



# H 1042

Serie WALKIRIA / design Panacom Architects Arseniy Leonovich



▲  
**Cromsatin** / Satin Chrome



**Cromo**  
Chrome



**Oro Lucido**  
Polished Brass

**Ottone** / Brass

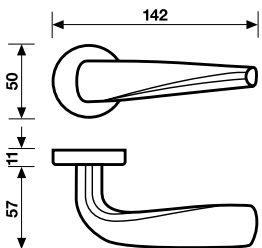

**H 1042 R8**  
**H 1042 R8 Y**

## Coordinato Matching Elements

**H 1042 F**  
**H 1042 F RS**  
Pg. 105

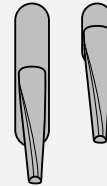

**K 1121**  
**K 1121 Y**  
Pg. 140



**M 1101**  
Pg. 165





# H 1041

Serie PORGY / design Yoshimi Kono



▲  
**Cromsatin** / Satin Chrome



**Orolux**  
Brass Plated

### Coordinato Matching Elements

**H 1041 F**  
**H 1041 F RS**  
Pg. 105

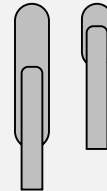

**K 1121**  
**K 1121 Y**  
Pg. 140



**Nikrall Lega Zama UNI 3717** / Nikrall Zamak alloy UNI 3717

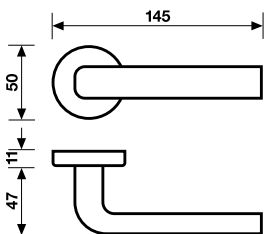

**H 1041 R8**  
**H 1041 R8 Y**





# H 1040

Serie SIBERIA / design Gabriele e Oscar Buratti



▲  
**Cromo** / Chrome



**Cromsatin**  
Satin Chrome



**Zirtanio Oro Lucido**  
Zirtanio-coated Polished Brass



**Bronzsat**  
Satin Bronze

**Ottone** / Brass

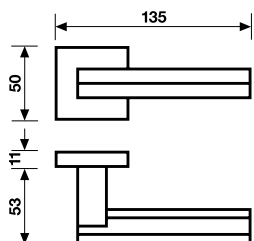

**H 1040 R8**  
**H 1040 R8 Y**

## Coordinato Matching Elements

**H 1040 F**  
**H 1040 F RS**  
Pg. 106

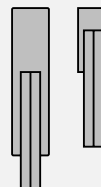

**K 1138**  
**K 1138 Y**  
Pg. 136



**K 1227**  
Pg. 129

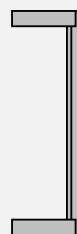

**M 1107**  
Pg. 165





# H 1039

Serie FEDRA / design Jean-Baptiste Sibertin Blanc



▲ **Cromsatin/Cromo** / Satin Chrome/Chrome



**Oro Lucido**  
Polished Brass

**Ottone** / Brass

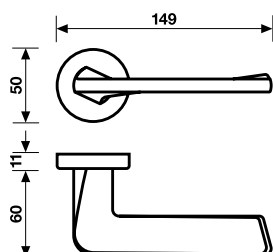

**H 1039 R8**  
**H 1039 R8 Y**

## Coordinato Matching Elements

**H 1039 F**  
**H 1039 F RS**  
Pg. 106

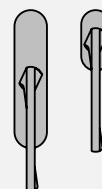

**K 1121**  
**K 1121 Y**  
Pg. 140



**K 1226**  
Pg. 130



**M 191**  
Pg. 166





# H 1038

Serie ARMIDA / design Decoma Design



▲  
**Cromsatin** / Satin Chrome



**Cromo/Cromsatin**  
Chrome/Satin Chrome

**Orolux/Orsatin**  
Brass Plated/Satin Brass

## Coordinato Matching Elements

**H 1038 F**  
**H 1038 F RS**  
Pg. 107

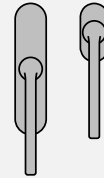

**K 1121**  
**K 1121 Y**  
Pg. 140



**M 1112**  
Pg. 164



**Nikrall Lega Zama UNI 3717** / Nikrall Zamak alloy UNI 3717

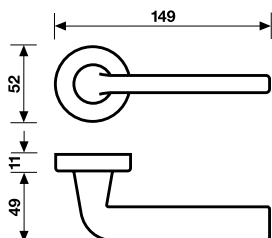

**H 1038 R8**  
**H 1038 R8 Y**



# H 1037

Serie TESEO / design Valli Workshop



▲  
**Oro Lucido** / Polished Brass



**Ottone Naturale Antico**  
Antique Natural Brass



**Brunito**  
Burnished

## Coordinato Matching Elements

**H 1037 F**  
**H 1037 F RS**  
Pg. 107

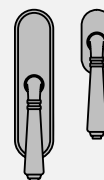

**K 1115**  
**K 1115 Y**  
Pg. 141



**M 1101**  
Pg. 165



Ottone / Brass

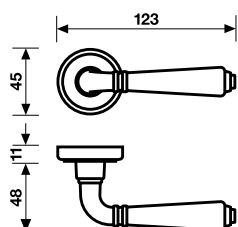

**H 1037 R8**  
**H 1037 R8 Y**





# H 1036

Serie AMIN / design Valli Workshop

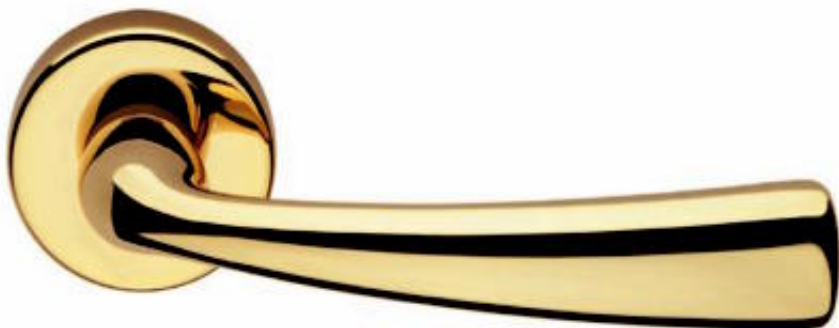

▲  
**Orolux** / Brass Plated



H 1036

Maniglie per Porta\Door Handles



**Cromsatin**  
Satin Chrome

## Coordinato Matching Elements

**H 1036 F**  
**H 1036 F RS**  
Pg. 108

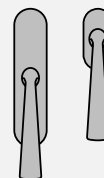

**K 1112**  
**K 1112 Y**  
Pg. 142



**M 1112**  
Pg. 164



**Nikrall Lega Zama UNI 3717** / Nikrall Zamak alloy UNI 3717

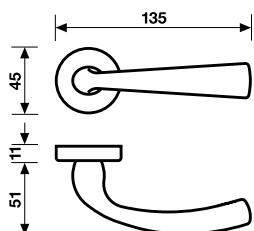

**H 1036 R8**  
**H 1036 R8 Y**



# H 123

Serie LUIGI XVI / design Valli Workshop



▲  
**Oro Lucido** / Polished Brass



**Ottone Naturale Antico**  
Antique Natural Brass

Ottone / Brass

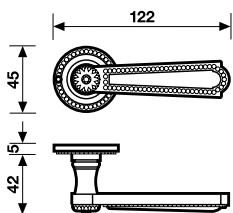

**H 123 R8**  
**H 123 R8 Y**

## Coordinato Matching Elements

**H 123 P8**  
Pg. 94

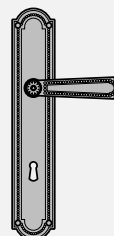

**H 123 F**  
**H 123 F RS**  
Pg. 108

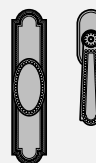

**K 121**  
Pg. 127



**K 195**  
**K 195 Y**  
Pg. 144



**M 1117**  
Pg. 163





# H 120

Serie LUIGI XV / design Valli Workshop



▲  
**Oro Lucido** / Polished Brass



**Ottone Naturale Antico**  
Antique Natural Brass

Ottone / Brass

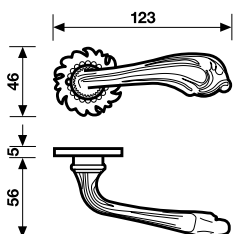

**H 120 R8**  
**H 120 R8 Y**

## Coordinato Matching Elements

**H 120 P8**  
Pg. 95

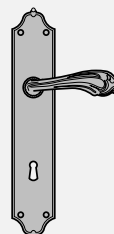

**H 120 F**  
**H 120 F RS**  
Pg. 109

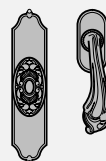

**K 120**  
Pg. 128



**K 194**  
**K 194 Y**  
Pg. 144



**M 1116**  
Pg. 163





# H 1034

Serie POLIS / design Decoma Design



▲  
**Cromo** / Chrome



**Cromsatin**  
Satin Chrome



**Zirtanio Oro Lucido**  
Zirtanio-coated Polished Brass

**ZIRTANIO**

## Coordinato Matching Elements

**H 1034 F**  
**H 1034 F RS**  
Pg. 109

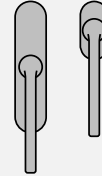

**K 1131**  
**K 1131 Y**  
Pg. 138



**M 1112**  
Pg. 164



**Nikrall Lega Zama UNI 3717** / Nikrall Zamak alloy UNI 3717

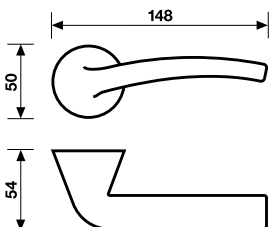

**H 1034 R8**  
**H 1034 R8 Y**





# H 1032

Serie CAPRICCIO / design Gensler Associates International



H 1032

Maniglie per Porta\Door Handles

▲  
**Cromo/Cromsatin** / Chrome/Satin Chrome



**Oro Lucido/Orsatin**  
Polished Brass / Satin Brass

**Ottone** / Brass

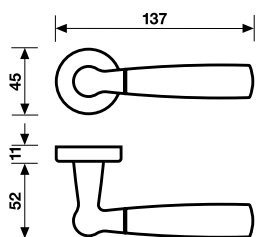

**H 1032 R8**  
**H 1032 R8 Y**

**Coordinato**  
Matching Elements

**H 1032 F**  
**H 1032 F RS**  
Pg. 110

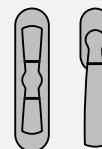

**K 1112**  
**K 1112 Y**  
Pg. 142



**M 1101**  
Pg. 165



**E 1021**  
Pg. 171



**K 1218**  
Pg. 130

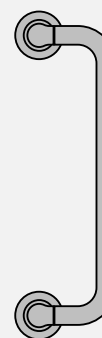



# H 1030

Serie ELISIR / design Sergio Asti



▲  
Oro / Brass



H 1030

Maniglie per Porta / Door Handles



**Brunito**  
Burnished

## Coordinato Matching Elements

**H 1030 F**  
**H 1030 F RS**  
Pg. 110

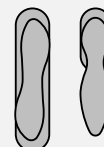

**K 1112**  
**K 1112 Y**  
Pg. 142



**M 1112**  
Pg. 164



Ottone / Brass

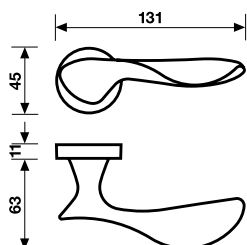

**H 1030 R8**  
**H 1030 R8 Y**



# H 1027

Serie DAFNE / design Studio Carlesi Design



▲  
**Oro Lucido** / Polished Brass



H 1027

Maniglie per Porta / Door Handles



**Cromsatin**  
Satin Chrome

**Ottone** / Brass

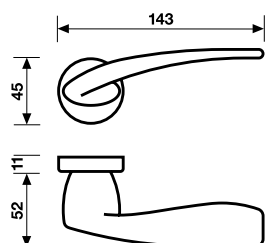

**H 1027 R8**  
**H 1027 R8 Y**

## Coordinato Matching Elements

**H 1027 F**  
**H 1027 F RS**  
Pg. 111

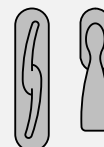

**K 1112**  
**K 1112 Y**  
Pg. 142



**M 1101**  
Pg. 165



**K 1216**  
Pg. 131





# H 1026

Serie DIDO / design Antonio Bullo



H 1026

Maniglie per Porta\Door Handles

▲  
**Cromsatin/Cromo** / Satin Chrome/Chrome



**Orsatin/Oro Lucido**  
Satin Brass/Polished Brass

## Coordinato Matching Elements

**H 1026 F**  
**H 1026 F RS**  
Pg. 111

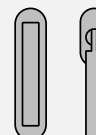

**K 1112**  
**K 1112 Y**  
Pg. 142



**M 1112**  
Pg. 164



**Ottone** / Brass

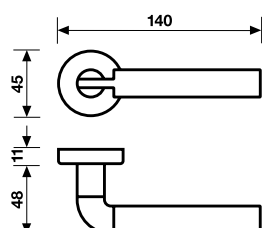

**H 1026 R8**  
**H 1026 R8 Y**





# H 1024

Serie LOLITA / design Valli Workshop



H 1024

Maniglie per Porta \ Door Handles

▲  
**Oro Lucido** / Polished Brass



**Orsatin**  
Satin Brass



**Cromo**  
Chrome



**Cromsatin**  
Satin Chrome

**Ottone** / Brass

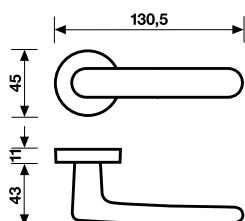

**H 1024 R8**  
**H 1024 R8 Y**

## Coordinato Matching Elements

**H 1024 F**  
**H 1024 F RS**  
Pg. 112

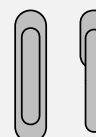

**K 1112**  
**K 1112 Y**  
Pg. 142



**M 191**  
Pg. 166





# H 1022

Serie ERNANI / design Valli Workshop



▲  
**Oro Lucido/Orsatin** / Polished Brass/Satin Brass



**Cromsatin/Cromo**  
Satin Chrome/Chrome

## Coordinato Matching Elements

**H 1022 F**  
**H 1022 F RS**  
Pg. 112

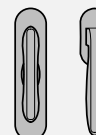

**K 1112**  
**K 1112 Y**  
Pg. 142



**Ottone** / Brass

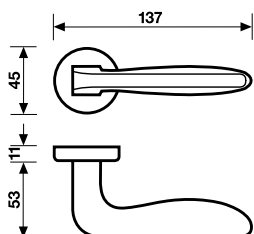

**H 1022 R8**  
**H 1022 R8 Y**



# H 1018

Serie OTELLO / design Marius Schreyer Design



▲  
**Oro Lucido** / Polished Brass



**Oro Lucido/Orsatin**  
Polished Brass/Satin Brass



**Cromo/Cromsatin**  
Chrome/Satin Chrome



**Cromsatin**  
Satin Chrome

**Ottone** / Brass

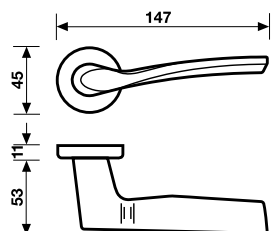

**H 1018 R8**  
**H 1018 R8 Y**

## Coordinato Matching Elements

**H 1018 F**  
**H 1018 F RS**  
Pg. 113

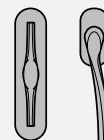

**K 1112**  
**K 1112 Y**  
Pg. 142





# H 1017

Serie CAMELIA / design Matteo Thun



H 1017

Maniglie per Porta \ Door Handles



▲  
**Oro Lucido** / Polished Brass



**Cromsatin**  
Satin Chrome

## Coordinato Matching Elements

**H 1017 F**  
**H 1017 F RS**  
Pg. 113

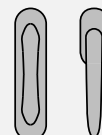

**K 1112**  
**K 1112 Y**  
Pg. 142

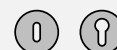

**M 191**  
Pg. 166



**Ottone** / Brass

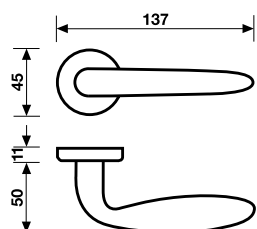

**H 1017 R8**  
**H 1017 R8 Y**





# H 1016

Serie NABUCCO / design Valli Workshop



▲  
**Oro Lucido** / Polished Brass



**Orsatin**  
Satin Brass



**Cromsatin**  
Satin Chrome



**Anticato**  
Antique

**Ottone** / Brass

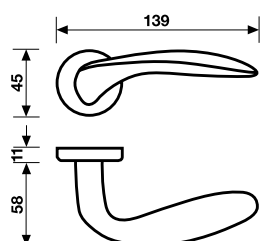

**H 1016 R8**  
**H 1016 R8 Y**

## Coordinato Matching Elements

**H 1016 F**  
**H 1016 F RS**  
Pg. 114

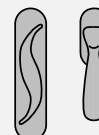

**K 1112**  
**K 1112 Y**  
Pg. 142





# H 1015

Serie WEST / design Itamar Harari



▲  
**Oro Lucido/Orsatin** / Polished Brass/Satin Brass



**Cromo/Cromsatin**  
Chrome/Satin Chrome

## Coordinato Matching Elements

**H 1015 F**  
**H 1015 F RS**  
Pg. 114

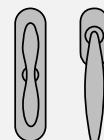

**K 1112**  
**K 1112 Y**  
Pg. 142



**M 1101**  
Pg. 165



**Ottone** / Brass

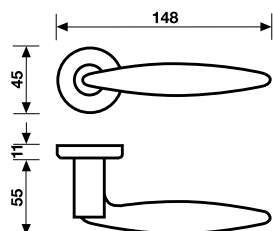

**H 1015 R8**  
**H 1015 R8 Y**



# H 1013

Serie MOSE' / design Valli Workshop



H 1013

Maniglie per Porta \ Door Handles

▲  
**Oro Lucido** / Polished Brass



**Ottone Naturale**  
Natural Brass



**Brunito**  
Burnished

## Coordinato Matching Elements

**H 1013 F**  
**H 1013 F RS**  
Pg. 115

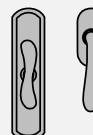

**K 1134**  
**K 1134 Y**  
Pg. 137



**M 191**  
Pg. 166



Ottone / Brass

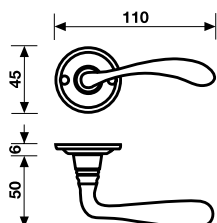

**H 1013 R8**  
**H 1013 R8 Y**



# H 1012

Serie POLIUTO / design Valli Workshop



▲  
**Oro Lucido** / Polished Brass



**Orsatin**  
Satin Brass



**Cromsatin**  
Satin Chrome

**Ottone** / Brass

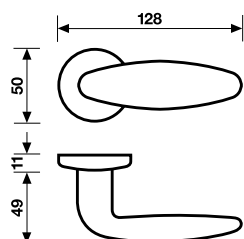

**H 1012 R8**  
**H 1012 R8 Y**

## Coordinato Matching Elements

**H 1012 F**  
**H 1012 F RS**  
Pg. 115

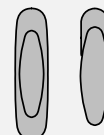

**K 1120**  
**K 1120 Y**  
Pg. 140



**M 1101**  
Pg. 165







# H 1010

Serie MEDEA / design Valli Workshop



▲  
**Oro Lucido** / Polished Brass



**Cromsatin**  
Satin Chrome

## Coordinato Matching Elements

**H 1010 F**  
**H 1010 F RS**  
Pg. 116

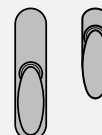

**K 1112**  
**K 1112 Y**  
Pg. 142



**M 1115**  
Pg. 164



**Ottone** / Brass

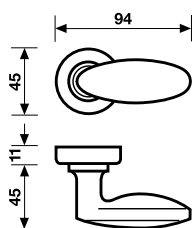

**H 1010 R8**  
**H 1010 R8 Y**



# H 1004

Serie ANTARES / design Valli Workshop



▲  
**Oro Lucido** / Polished Brass



**Oro Lucido/Orsatin**  
Polished Brass/Satin Brass



**Oro Lucido/Bianco**  
Polished Brass/White



**Ottone Naturale**  
Natural Brass



**Brunito**  
Burnished



**Brunito/Avorio**  
Burnished/Ivory



**Fumé**  
Fumé

**Ottone** / Brass

**Ottone e Porcellana** / Brass and Porcelain

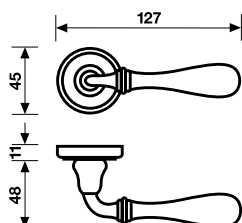

**H 1004 R8**  
**H 1004 R8 Y**

## Coordinato Matching Elements

**H 1004 P8**  
Pg. 96

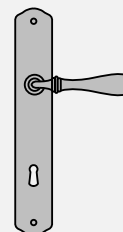

**H 1004 F**  
**H 1004 F RS**  
Pg. 116

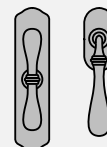

**K 1110**  
**K 1110 Y**  
Pg. 142



**M 1101**  
Pg. 165





# H 1003

Serie CROCO / design Matteo Thun



▲  
**Oro Lucido** / Polished Brass



**Oro Lucido/Orsatin**  
Polished Brass/Satin Brass



**Orsatin**  
Satin Brass



**Cromo/Cromsatin**  
Chrome/Satin Chrome



**Cromsatin**  
Satin Chrome



**Anticato**  
Antique

**Ottone** / Brass

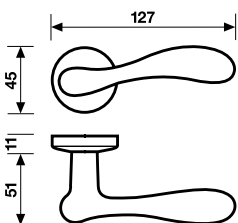

**H 1003 R8**  
**H 1003 R8 Y**

## Coordinato Matching Elements

**H 1003 P8**  
Pg. 97

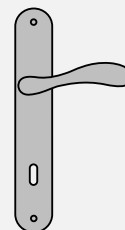

**H 1003 F**  
**H 1003 F RS**  
Pg. 117

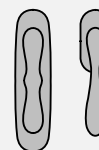

**K 1119**  
**K 1119 Y**  
Pg. 141



**M 191**  
Pg. 166





# H 1000

Serie ANGELICA / design Valli Workshop



H 1000

Maniglie per Porta / Door Handles

▲  
**Oro Lucido/Trasparente** / Polished Brass/Transparent



**Oro Lucido/Trasparente Opaco**  
Polished Brass/Matt Transparent

**Cromsatin/Trasparente Opaco**  
Matt Chrome/Matt Transparent

## Coordinato Matching Elements

**H 1000 F**  
**H 1000 F RS**  
Pg. 117



**K 1128**  
**K 1128 Y**  
Pg. 139



**Ottone e Vetro di Murano** / Brass and Murano glass

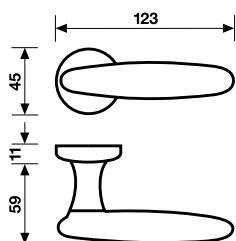

**H 1000 R8**  
**H 1000 R8 Y**





# H 914/8

Serie MEDICEA / design Pasquale Valli



▲  
**Patiné** / Patiné



## Coordinato Matching Elements

**H 914/8**  
Pg. 98

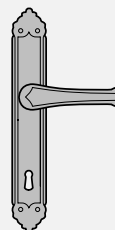

**H 916 F**  
**H 914 F RS**  
Pg. 118

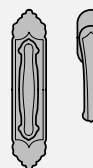

**K 915**  
**K 915 Y**  
Pg. 143

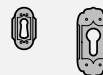

**Ottone** / Brass

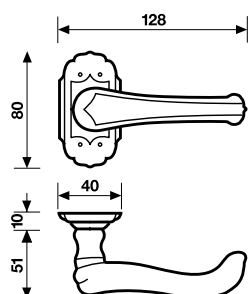

**H 915/8 R8**  
**H 915/8 R8 Y**



# H 227

Serie RIGEL / design Valli Workshop



▲  
**Orolux** / Brass Plated



H 227

Maniglie per Porta \ Door Handles



**Anticato**  
Antique

## Coordinato Matching Elements

**H 227 F**  
**H 227 F RS**  
Pg. 118

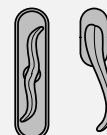

**K 292**  
**K 292 Y**  
Pg. 143



**Nikrall Lega Zama UNI 3717** / Nikrall Zamak alloy UNI 3717

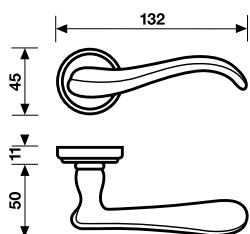

**H 227 R8**  
**H 227 R8 Y**



# H 198

Serie MIZAR / design Eero Aarnio



H 198

Maniglie per Porta \ Door Handles

▲  
**Oro Lucido** / Polished Brass



**Orsatin**  
Satin Brass



**Cromo**  
Chrome



**Cromsatin**  
Satin Chrome



**Anticato**  
Antique

**Ottone** / Brass

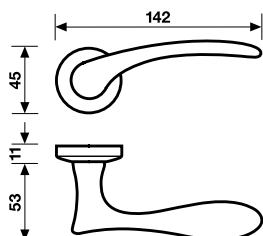

**H 198 R8**  
**H 198 R8 Y**

## Coordinato Matching Elements

**H 198 P8**  
Pg. 99

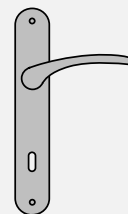

**H 198 F**  
**H 198 F RS**  
Pg. 119

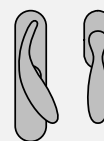

**K 1119**  
**K 1119 Y**  
Pg. 141



**K 1210**  
Pg. 131





# H 196

Serie ULISSE L / design Cozza e Mascheroni



H 196

Maniglie per Porta / Door Handles

▲  
**Oro Lucido/Ormatt** / Polished Brass/Matt Brass



**Cromo/Cromsatin**  
Chrome/Satin Chrome

## Coordinato Matching Elements

**H 196 F**  
**H 196 F RS**  
Pg. 119

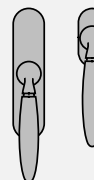

**K 1131**  
**K 1131 Y**  
Pg. 138



**Ottone** / Brass

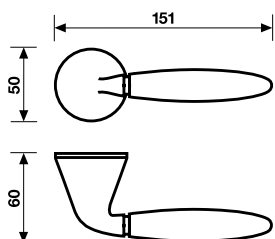

**H 196 R8**  
**H 196 R8 Y**





# H 195

Serie ORCHIDEA / design Valli Workshop



▲  
**Oro Lucido** / Polished Brass



**Cromsatin**  
Satin Chrome



**Zirtanio Oro Lucido**  
Zirtanio-coated Polished Brass



## Coordinato Matching Elements

**H 195 F**  
**H 195 F RS**  
Pg. 120

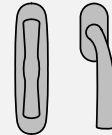

**K 1119**  
**K 1119 Y**  
Pg. 141



**M 1112**  
Pg. 164



**Ottone** / Brass

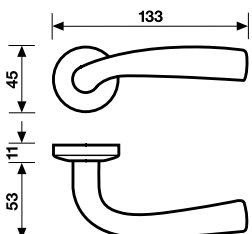

**H 195 R8**  
**H 195 R8 Y**



# H 192

Serie PRUNUS / design Valli Workshop



▲  
**Oro Lucido** / Polished Brass



**Nikmatt**  
Nikmatt

## Coordinato Matching Elements

**H 192 F**  
**H 192 F RS**  
Pg. 120

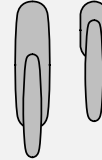

**K 1128**  
**K 1128 Y**  
Pg. 139



**Ottone** / Brass

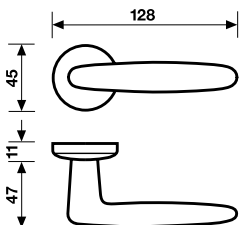

**H 192 R8**  
**H 192 R8 Y**



# H 179

Serie AIDA / design Matteo Thun



▲  
**Oro Lucido** / Polished Brass



## Coordinato Matching Elements

**H 179 F**  
**H 179 F RS**  
Pg. 121

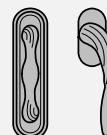

**K 1110**  
**K 1110 Y**  
Pg. 142



**K 1181**  
Pg. 133



**Ottone** / Brass

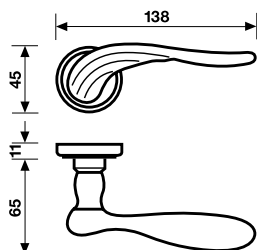

**H 179 R8**  
**H 179 R8 Y**



# H 176

Serie SPIGA / design Valli Workshop



H 176

Maniglie per Porta\Door Handles



▲  
**Bianco/Oro Lucido** / White/Polished Brass



**Fiorato/Oro Lucido**  
Floral/Polished Brass



**Brunito/Avorio**  
Burnished/Ivory



**Brunito/Fiorato**  
Burnished/Floral

**Ottone e Porcellana** / Brass and Porcelain

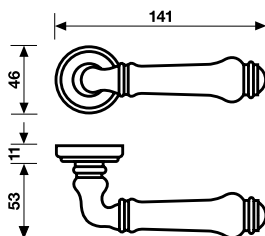

**H 176 R8**  
**H 176 R8 Y**

## Coordinato Matching Elements

**H 176 F**  
**H 176 F RS**  
Pg. 121

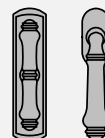

**K 1115**  
**K 1115 Y**  
Pg. 141



**M 1101**  
Pg. 165



**F 141**  
Pg. 179



**N 120**  
Pg. 167







# H 174

Serie ALTAIR / design Valli Workshop



H 174

Maniglie per Porta \ Door Handles



▲  
**Oro Lucido** / Polished Brass

## Coordinato Matching Elements

**H 174 F**  
**H 174 F RS**  
Pg. 122

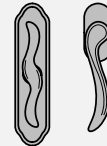

**K 1115**  
**K 1115 Y**  
Pg. 141



**M 1101**  
Pg. 165



**Ottone** / Brass

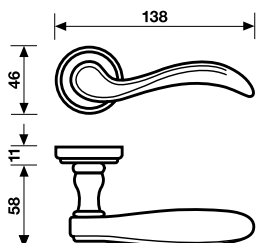

**H 174 R8**  
**H 174 R8 Y**



# H 165

Serie GERMANA / design Valli Workshop



▲  
**Oro Lucido** / Polished Brass



**Orsatin**  
Satin Brass



**Anticato**  
Antique

**Ottone** / Brass

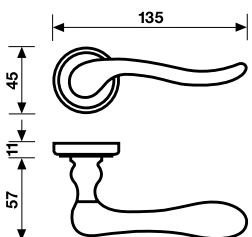

**H 165 R8**  
**H 165 R8 Y**

## Coordinato Matching Elements

**H 165 P8**  
Pg. 100

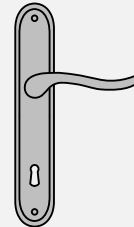

**H 165 F**  
**H 165 F RS**  
Pg. 122

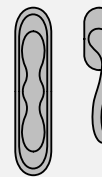

**K 140**  
Pg. 127



**K 1110**  
**K 1110 Y**  
Pg. 142



**M 194**  
Pg. 166





# H 163

Serie SARISSA / design Valli Workshop



▲  
**Oro Lucido** / Polished Brass



H 163

Maniglie per Porta \ Door Handles



**Cromo**  
Chrome



**Cromsatin**  
Satin Chrome

**Ottone** / Brass

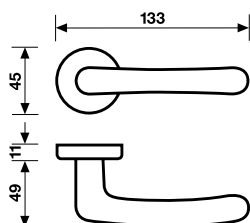

**H 163 R8**  
**H 163 R8 Y**

## Coordinato Matching Elements

**H 163 P8**  
Pg. 101

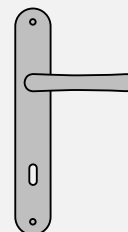

**H 163 F**  
**H 163 F RS**  
Pg. 123

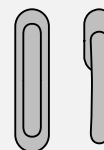

**K 1112**  
**K 1112 Y**  
Pg. 142





# H 123

Serie LUIGI XVI / design Valli Workshop



◀ **Oro Lucido** / Polished Brass  
**Ottone Naturale Antico** / Antique Natural Brass

Ottone / Brass

**Coordinato**  
 Matching Elements

**H 123 R8**  
 Pg. 34



**H 123 F**  
**H 123 F RS**  
 Pg. 98

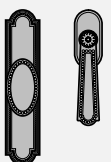

**K 121**  
 Pg. 127



**K 195**  
**K 195 Y**  
 Pg. 144



**M 1117**  
 Pg. 163

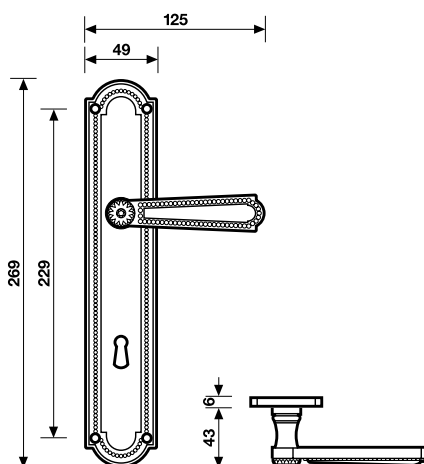

**H 123 P8 70**  
**H 123 P8 90**  
**H 123 P8 Y 85**

# H 120

Serie LUIGI XV / design Valli Workshop



◀ **Oro Lucido** / Polished Brass  
**Ottone Naturale Antico** / Antique Natural Brass

Ottone / Brass

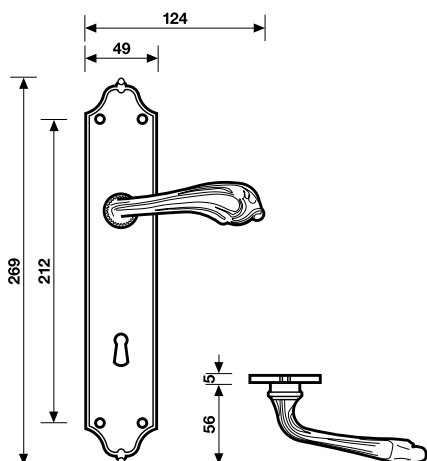

**H 120 P8 70**  
**H 120 P8 90**  
**H 120 P8 Y 85**



H 120

Maniglie per Porta \ Door Handles

95

## Coordinato Matching Elements

**H 120 R8**  
Pg. 36



**H 120 F**  
**H 120 F RS**  
Pg. 109

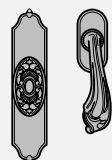

**K 120**  
Pg. 128



**K 194**  
**K 194 Y**  
Pg. 144



**M 1116**  
Pg. 163







# H 1004

Serie ANTARES / design Valli Workshop



◀ **Oro Lucido** / Polished Brass  
**Brunito** / Burnished

**Ottone** / Brass

**Coordinato**  
Matching Elements

**H 1004 R8**  
Pg. 66



**H 1004 F**  
**H 1004 F RS**  
Pg. 116

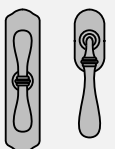

**K 1110**  
**K 1110 Y**  
Pg. 142



**M 1101**  
Pg. 165

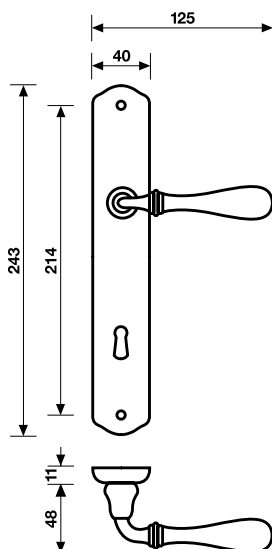

**H 1004 P8 70**  
**H 1004 P8 90**  
**H 1004 P8 Y 85**

# H 1003

Serie CROCO / design Matteo Thun



◀ **Oro Lucido** / Polished Brass

**Ottone** / Brass

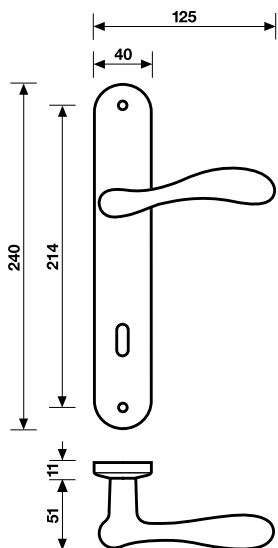

**H 1003 P8 70**  
**H 1003 P8 90**  
**H 1003 P8 Y 85**



## Coordinato Matching Elements

**H 1003 R8**  
Pg. 69



**H 1003 F**  
**H 1003 F RS**  
Pg. 117

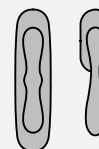

**K 1119**  
**K 1119 Y**  
Pg. 141



**M 191**  
Pg. 166





# H 914/8

Serie MEDICEA / design Pasquale Valli



◀ Patiné / Patiné

Ottone / Brass

### Coordinato Matching Elements

**H 915/8**  
Pg. 72

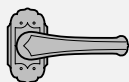

**H 916 F**  
**H 914 F RS**  
Pg. 118

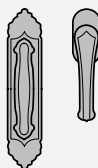

**K 915**  
**K 915 Y**  
Pg. 143

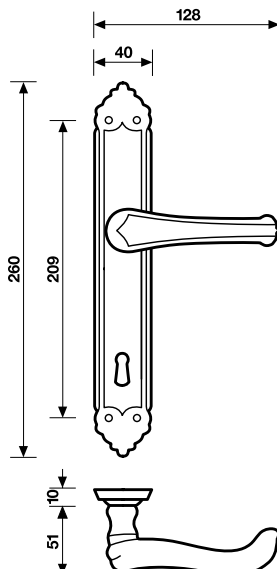

**H 914/8 P8 70**  
**H 914/8 P8 90**  
**H 914/8 P8 Y 85**

# H 198

Serie MIZAR / design Eero Aarnio



◀ **Oro Lucido** / Polished Brass  
**Anticato** / Antique

Ottone / Brass

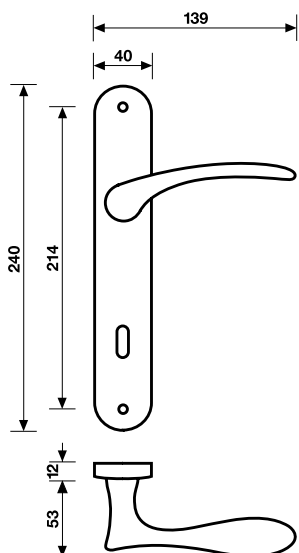

**H 198 P8 70**  
**H 198 P8 90**  
**H 198 P8 Y 85**



## Coordinato Matching Elements

**H 198 R8**  
Pg. 76



**H 198 F**  
**H 198 F RS**  
Pg. 119



**K 1119**  
**K 1119 Y**  
Pg. 141



**K 1210**  
Pg. 131





# H 165

Serie GERMANA / design Valli Workshop



◀ **Oro Lucido** / Polished Brass  
**Anticato** / Antique

**Ottone** / Brass

**Coordinato**  
Matching Elements

**H 165 R8**  
Pg. 90



**H 165 F**  
**H 165 F RS**  
Pg. 122

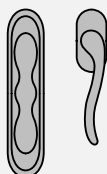

**K 140**  
Pg. 127



**K 1110**  
**K 1110 Y**  
Pg. 142



**M 194**  
Pg. 166

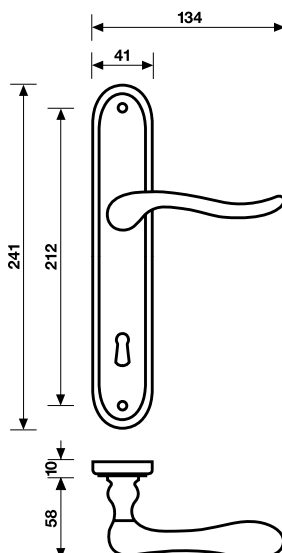

**H 165 P8 70**  
**H 165 P8 90**  
**H 165 P8 Y 85**

# H 163

Serie GERMANA / design Valli Workshop



H 163

Maniglie per Porta \ Door Handles



◀ **Oro Lucido** / Polished Brass

**Ottone** / Brass

## Coordinato Matching Elements

**H 163 R8**  
Pg. 92



**H 163 F**  
**H 163 F RS**  
Pg. 123

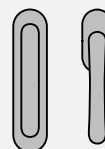

**K 1112**  
**K 1112 Y**  
Pg. 142

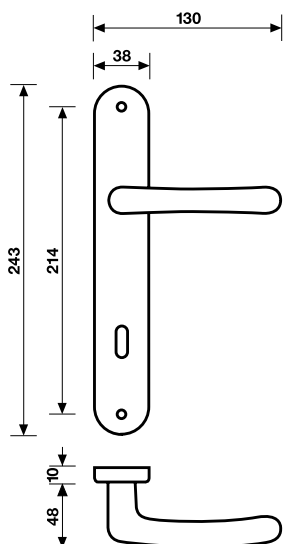

**H 163 P8 70**  
**H 163 P8 90**  
**H 163 P8 Y 85**



# H 1048

Serie ORIONE / design Ludovica + Roberto Palomba

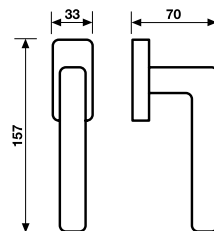
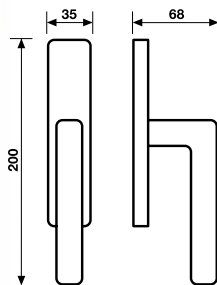

**H 1048 F**  
**Movimenti**  
 Movements  
 Gratz  
 Gratz CP  
 Gratz/7  
 Martellina

**Ottone** / Brass

**Cromo** / Chrome  
**Cromsatin** / Satin Chrome

**H 1048 F RS**  
**Movimento F RS**  
**4 scatti**  
 Movement  
 4 click positions

Maniglia per Porta / Door Handle Pg. 8

# H 1047

Serie ZAIDE / design Emanuela Frattini

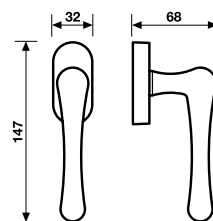
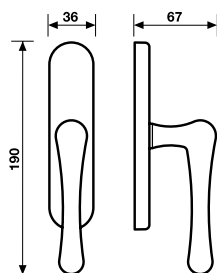

**H 1047 F**  
**Movimenti**  
 Movements  
 Gratz  
 Gratz CP  
 Gratz/7  
 Martellina

**Ottone** / Brass

**Oro Lucido** / Polished Brass  
**Cromo** / Chrome  
**Cromsatin** / Satin Chrome  
**Anticato** / Antique

**H 1047 F RS**  
**Movimento F RS**  
**4 scatti**  
 Movement  
 4 click positions

Maniglia per Porta / Door Handle Pg. 10

# H 1046

Serie NAIS / design Valli Workshop

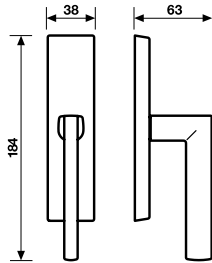

## H 1046 F

### Movimenti

Movements  
Gratz  
Gratz CP  
Gratz/7  
Martellina

Ottone / Brass

Cromo / Chrome

Cromsatin / Satin Chrome

Maniglia per Porta / Door Handle Pg. 12

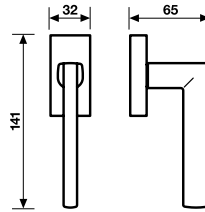

## H 1046 F RS

### Movimento F RS

4 scatti  
Movement  
4 click positions



# H 1045

Serie BESS / design Yoshimi Kono

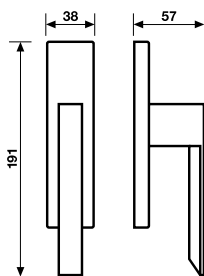

## H 1045 F

### Movimenti

Movements  
Gratz  
Gratz CP  
Gratz/7  
Martellina

Nikrall Lega Zama UNI 3717 / Nikrall Zamak Alloy UNI 3717

Cromo / Chrome

Cromsatin/Cromo / Satin Chrome/Chrome

Orolux / Brass Plated

Maniglia per Porta / Door Handle Pg. 14

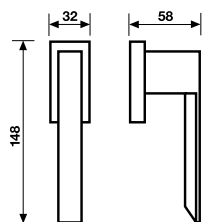

## H 1045 F RS

### Movimento F RS

4 scatti  
Movement  
4 click positions





# H 1044

Serie OBERON / design Vincent Van Duysen

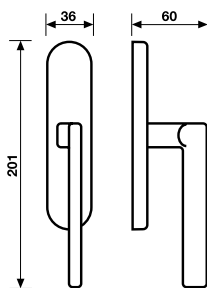

**H 1044 F**  
**Movimenti**  
 Movements  
 Gratz  
 Gratz CP  
 Gratz/7  
 Martellina

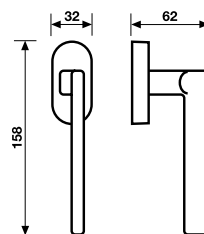

**H 1044 F RS**  
**Movimento F RS**  
**4 scatti**  
 Movement  
 4 click positions

**Nikrall Lega Zama UNI 3717 / Nikrall Zamak Alloy UNI 3717**

**Cromo / Chrome**  
**Cromsatin / Satin Chrome**  
**Orolux / Brass Plated**

Maniglia per Porta / Door Handle Pg. 16

# H 1043

Serie ALCINA / design Matteo Thun

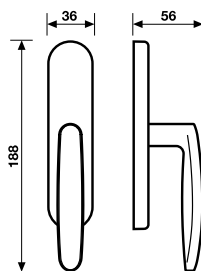

**H 1043 F**  
**Movimenti**  
 Movements  
 Gratz  
 Gratz CP  
 Gratz/7  
 Martellina

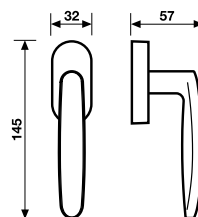

**H 1043 F RS**  
**Movimento F RS**  
**4 scatti**  
 Movement  
 4 click positions

**Nikrall Lega Zama UNI 3717 / Nikrall Zamak alloy UNI 3717**

**Cromo/Cromsatin / Chrome/Satin Chrome**  
**Orolux/Orsatin / Brass Plated/Satin Brass**

Maniglia per Porta / Door Handle Pg. 18

# H 1042

Serie WALKIRIA / design Panacom Architects Arseniy Leonovich

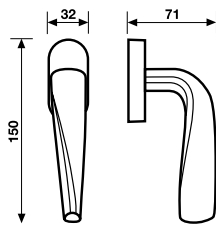
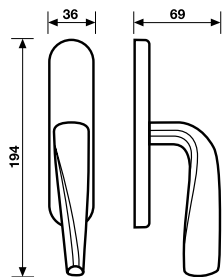

**H 1042 F**  
**Movimenti**  
Movements  
Gratz  
Gratz CP  
Gratz/7  
Martellina

**H 1042 F RS**  
**Movimento F RS**  
**4 scatti**  
Movement  
4 click positions

**Ottone** / Brass

**Cromo** / Chrome

**Cromsatin** / Satin Chrome

**Oro Lucido** / Polished Brass

Maniglia per Porta / Door Handle Pg. 20



# H 1041

Serie PORGY / design Yoshimi Kono

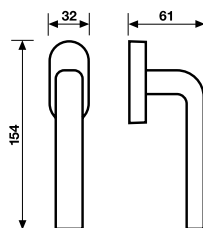
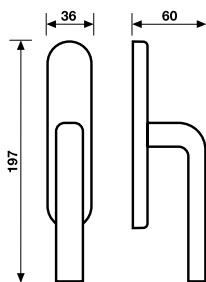

**H 1041 F**  
**Movimenti**  
Movements  
Gratz  
Gratz CP  
Gratz/7  
Martellina

**H 1041 F RS**  
**Movimento F RS**  
**4 scatti**  
Movement  
4 click positions

**Nikrall Lega Zama UNI 3717** / Nikrall Zamak Alloy UNI 3717

**Cromsatin** / Satin Chrome

**Orolux** / Brass Plated

Maniglia per Porta / Door Handle Pg. 22



# H 1040

Serie SIBERIA / design Gabriele e Oscar Buratti

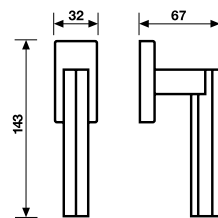
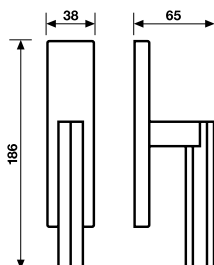

**H 1040 F**  
**Movimenti**  
 Movements  
 Gratz  
 Gratz CP  
 Gratz/7  
 Martellina

**H 1040 F RS**  
**Movimento F RS**  
**4 scatti**  
 Movement  
 4 click positions

**Ottone** / Brass

**Cromo** / Chrome  
**Cromsatin** / Satin Chrome  
**Zirtanio Oro Lucido** / Zirtanio-coated Polished Brass  
**Bronzsat** / Satin Bronze

Maniglia per Porta / Door Handle Pg. 24

# H 1039

Serie FEDRA / design Jean-Baptiste Sibertin Blanc

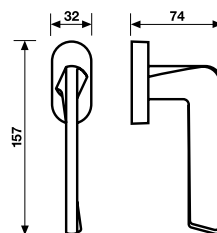
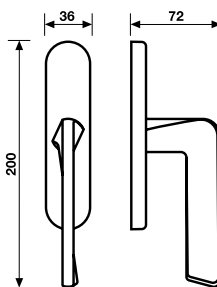

**H 1039 F**  
**Movimenti**  
 Movements  
 Gratz  
 Gratz CP  
 Gratz/7  
 Martellina

**H 1039 F RS**  
**Movimento F RS**  
**4 scatti**  
 Movement  
 4 click positions

**Ottone** / Brass

**Cromsatin/Cromo** / Satin Chrome/Chrome  
**Oro Lucido** / Polished Brass

Maniglia per Porta / Door Handle Pg. 26

# H 1038

Serie ARMIDA / design Decoma Design

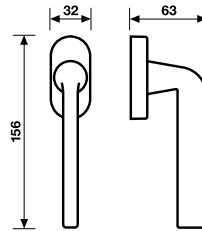
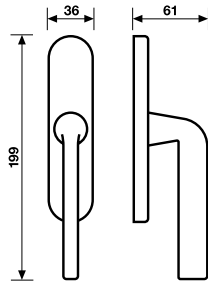

**H 1038 F**  
**Movimenti**  
Movements  
Gratz  
Gratz CP  
Gratz/7  
Martellina

**H 1038 F RS**  
**Movimento F RS**  
**4 scatti**  
Movement  
4 click positions

**Nikrall Lega Zama UNI 3717** / Nikrall Zamak alloy UNI 3717

**Cromsatin** / Satin Chrome  
**Cromo/Cromsatin** / Chrome/Satin Chrome  
**Orolux/Orsatin** / Brass Plated/Satin Brass

Maniglia per Porta / Door Handle Pg. 28



# H 1037

Serie TESEO / design Valli Workshop

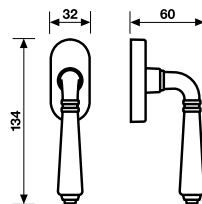
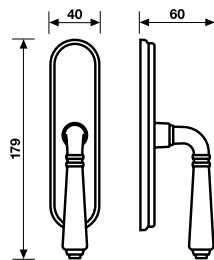

**H 1037 F**  
**Movimenti**  
Movements  
Gratz  
Gratz CP  
Gratz/7  
Martellina

**H 1037 F RS**  
**Movimento F RS**  
**4 scatti**  
Movement  
4 click positions

**Ottone** / Brass

**Oro Lucido** / Polished Brass  
**Ottone Naturale Antico** / Antique Natural Brass  
**Brunito** / Burnished

Maniglia per Porta / Door Handle Pg. 30



# H 1036

Serie AMIN / design Valli Workshop

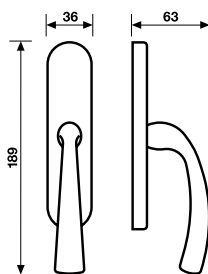

**H 1036 F**  
**Movimenti**  
 Movements  
 Gratz  
 Gratz CP  
 Gratz/7  
 Martellina

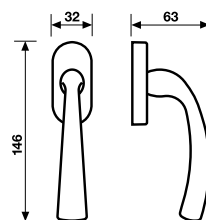

**H 1036 F RS**  
**Movimento F RS**  
**4 scatti**  
 Movement  
 4 click positions

**Nikrall Lega Zama UNI 3717 / Nikrall Zamak Alloy UNI 3717**

**Orolux / Brass Plated**  
**Cromsatin / Satin Chrome**

Maniglia per Porta / Door Handle Pg. 32

# H 123

Serie LUIGI XVI / design Valli Workshop

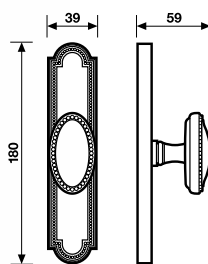

**H 123 F**  
**Movimenti**  
 Movements  
 Gratz  
 Gratz CP  
 Gratz/7  
 Martellina

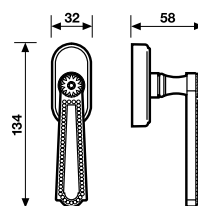

**H 123 F RS**  
**Movimento F RS**  
**4 scatti**  
 Movement  
 4 click positions

**Ottone / Brass**

**Oro Lucido / Polished Brass**  
**Ottone Naturale Antico / Antique Natural Brass**

Maniglia per Porta / Door Handle Pg. 34

# H 120

Serie LUIGI XV / design Valli Workshop

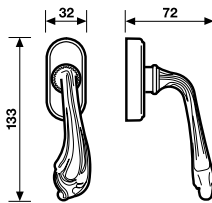
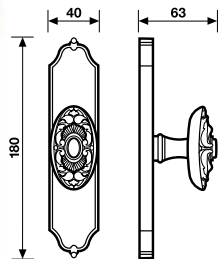

## H 120 F

### Movimenti

Movements  
Gratz  
Gratz CP  
Gratz/7  
Martellina

Ottone / Brass

Oro Lucido / Polished Brass

Ottone Naturale Antico / Antique Natural Brass

Maniglia per Porta / Door Handle Pg. 36

## H 120 F RS

### Movimento F RS

4 scatti  
Movement  
4 click positions



# H 1034

Serie POLIS / design Decoma Design

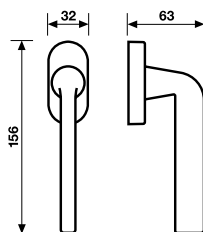
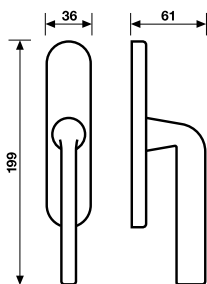

## H 1034 F

### Movimenti

Movements  
Gratz  
Gratz CP  
Gratz/7  
Martellina

Nikrall Lega Zama UNI 3717 / Nikrall Zamak Alloy UNI 3717

Cromo / Chrome

Cromsatin / Satin Chrome

Zirtanio Oro Lucido / Zirtanio-coated Polished Brass



Maniglia per Porta / Door Handle Pg. 38

## H 1034 F RS

### Movimento F RS

4 scatti  
Movement  
4 click positions



# H 1032

Serie CAPRICCIO / design Gensler Associates International

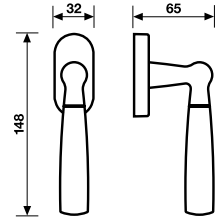
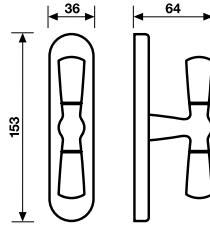

## H 1032 F

### Movimenti

Movements  
Gratz  
Gratz CP  
Gratz/7  
Martellina

Ottone / Brass

Cromo/Cromsatin / Chrome/Satin Chrome

Oro Lucido/Orsatin / Polished Brass/Satin Brassv

## H 1032 F RS

### Movimento F RS

4 scatti  
Movement  
4 click positions

Maniglia per Porta / Door Handle Pg. 40

# H 1030

Serie ELISIR / design Sergio Asti

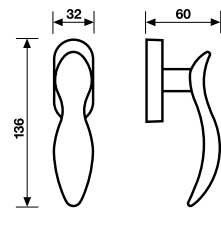
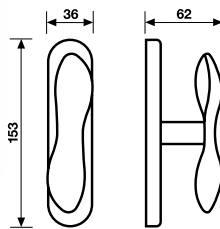

## H 1030 F

### Movimenti

Movements  
Gratz  
Gratz CP  
Gratz/7  
Martellina

Ottone / Brass

Oro / Brass

Brunito/ Burnished

## H 1030 F RS

### Movimento F RS

4 scatti  
Movement  
4 click positions

Maniglia per Porta / Door Handle Pg. 42

# H 1027

Serie DAFNE / design Studio Carlesi Design

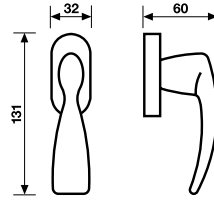
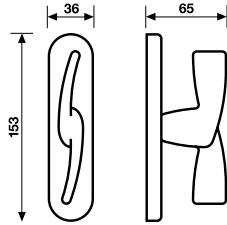

## H 1027 F

### Movimenti

Movements  
Gratz  
Gratz CP  
Gratz/7  
Martellina

Ottone / Brass

Oro Lucido / Polished Brass  
Cromsatin / Satin Chrome

Maniglia per Porta / Door Handle Pg. 44

## H 1027 F RS

### Movimento F RS

4 scatti  
Movement  
4 click positions



# H 1026

Serie DIDO / design Antonio Bullo

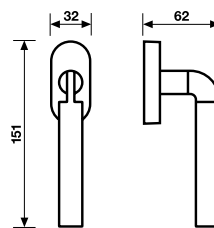
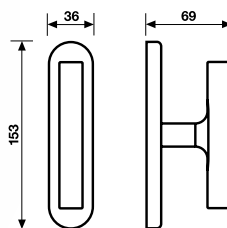

## H 1026 F

### Movimenti

Movements  
Gratz  
Gratz CP  
Gratz/7  
Martellina

Ottone / Brass

Cromsatin/Cromo / Satin Chrome/Chrome  
Orsatin/Oro Lucido / Satin Brass/Polished Brass

Maniglia per Porta / Door Handle Pg. 46

## H 1026 F RS

### Movimento F RS

4 scatti  
Movement  
4 click positions





# H 1024

Serie LOLITA / design Valli Workshop

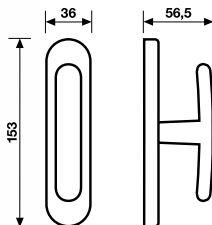

**H 1024 F**  
**Movimenti**  
 Movements  
 Gratz  
 Gratz CP  
 Gratz/7  
 Martellina

**Ottone** / Brass

**Oro Lucido** / Polished Brass  
**Orsatin** / Satin Brass  
**Cromo** / Chrome  
**Cromsatin** / Satin Chrome

Maniglia per Porta / Door Handle Pg. 48

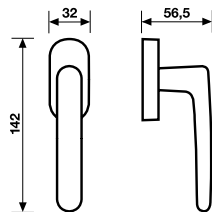

**H 1024 F RS**  
**Movimento F RS**  
**4 scatti**  
 Movement  
 4 click positions

# H 1022

Serie ERNANI / design Valli Workshop

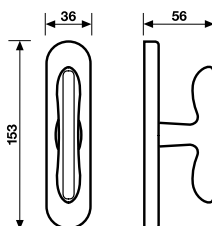

**H 1022 F**  
**Movimenti**  
 Movements  
 Gratz  
 Gratz CP  
 Gratz/7  
 Martellina

**Ottone** / Brass

**Oro Lucido/Orsatin** / Polished Brass/Satin Brass  
**Cromsatin/Cromo** / Satin Chrome/Chrome

Maniglia per Porta / Door Handle Pg. 50

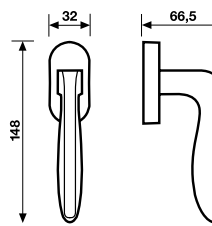

**H 1022 F RS**  
**Movimento F RS**  
**4 scatti**  
 Movement  
 4 click positions

# H 1018

Serie OTELLO / design Marius Schreyer Design

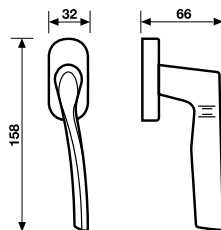
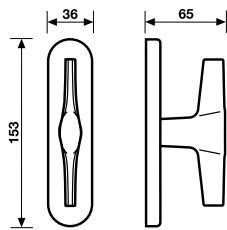

**H 1018 F**  
**Movimenti**  
Movements  
Gratz  
Gratz CP  
Gratz/7  
Martellina

**H 1018 F RS**  
**Movimento F RS**  
**4 scatti**  
Movement  
4 click positions

**Ottone** / Brass

**Oro Lucido** / Polished Brass

**Cromsatin** / Satin Chrome

**Solo** / Only **H 1018 F RS**

**Oro Lucido/Orsatin** / Polished Brass/Satin Brass

**Cromo/Cromsatin** / Chrome/Satin Chrome

Maniglia per Porta / Door Handle Pg. 52



# H 1017

Serie CAMELIA / design Matteo Thun

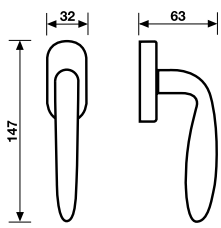
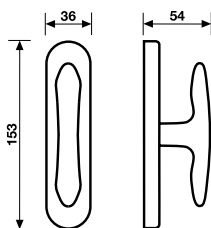

**H 1017 F**  
**Movimenti**  
Movements  
Gratz  
Gratz CP  
Gratz/7  
Martellina

**H 1017 F RS**  
**Movimento F RS**  
**4 scatti**  
Movement  
4 click positions

**Ottone** / Brass

**Oro Lucido** / Polished Brass

**Cromsatin** / Satin Chrome

Maniglia per Porta / Door Handle Pg. 54



# H 1016

Serie NABUCCO / design Valli Workshop

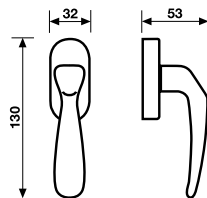
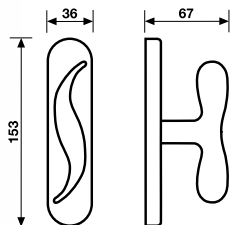

**H 1016 F**  
**Movimenti**  
 Movements  
 Gratz  
 Gratz CP  
 Gratz/7  
 Martellina

**Ottone** / Brass

**Oro Lucido** / Polished Brass  
**Orsatin** / Satin Brass  
**Cromsatin** / Satin Chrome  
**Anticato** / Antique

**H 1016 F RS**  
**Movimento F RS**  
**4 scatti**  
 Movement  
 4 click positions

Maniglia per Porta / Door Handle Pg. 56

# H 1015

Serie WEST / design Itamar Harari

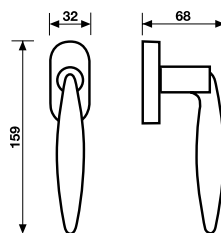
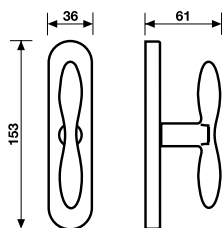

**H 1015 F**  
**Movimenti**  
 Movements  
 Gratz  
 Gratz CP  
 Gratz/7  
 Martellina

**Ottone** / Brass

**Oro Lucido/Orsatin** / Polished Brass/Satin Brass  
**Cromo/Cromsatin** / Chrome/Satin Chrome

**H 1015 F RS**  
**Movimento F RS**  
**4 scatti**  
 Movement  
 4 click positions

Maniglia per Porta / Door Handle Pg. 58

# H 1013

Serie MOSE' / design Valli Workshop

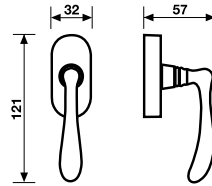
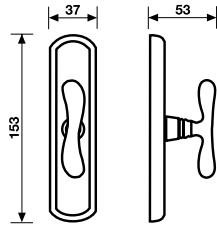

**H 1013 F**  
**Movimenti**  
Movements  
Gratz  
Gratz CP  
Gratz/7  
Martellina

**Ottone** / Brass

**Oro Lucido** / Polished Brass  
**Ottone Naturale** / Natural Brass  
**Brunito** / Burnished

Maniglia per Porta / Door Handle Pg. 60

**H 1013 F RS**  
**Movimento F RS**  
**4 scatti**  
Movement  
4 click positions



# H 1012

Serie POLIUTO / design Valli Workshop

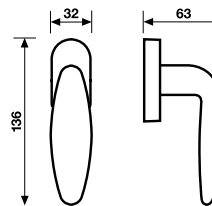
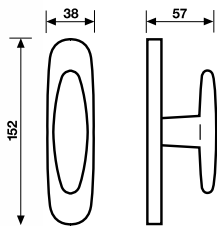

**H 1012 F**  
**Movimenti**  
Movements  
Gratz  
Gratz CP  
Gratz/7  
Martellina

**Ottone** / Brass

**Oro Lucido** / Polished Brass  
**Orsatin** / Satin Brass  
**Cromsatin** / Satin Chrome

Maniglia per Porta / Door Handle Pg. 62

**H 1012 F RS**  
**Movimento F RS**  
**4 scatti**  
Movement  
4 click positions



# H 1010

Serie MEDEA / design Valli Workshop

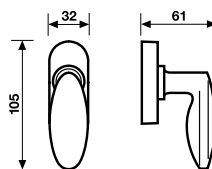
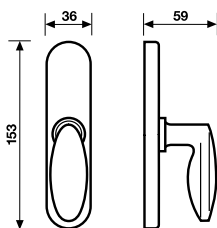

**H 1010 F**  
**Movimenti**  
 Movements  
 Gratz  
 Gratz CP  
 Gratz/7  
 Martellina

**Ottone** / Brass

**Oro Lucido** / Polished Brass  
**Cromsatin** / Satin Chrome

**H 1010 F RS**  
**Movimento F RS**  
**4 scatti**  
 Movement  
 4 click positions

Maniglia per Porta / Door Handle Pg. 64

# H 1004

Serie ANTARES / design Valli Workshop

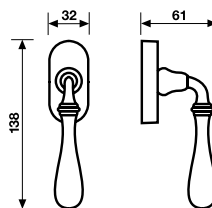
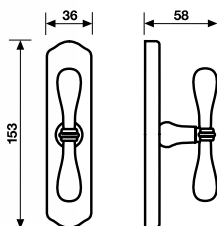

**H 1004 F**  
**Movimenti**  
 Movements  
 Gratz  
 Gratz CP  
 Gratz/7  
 Martellina

**Ottone** / Brass

**Oro Lucido** / Polished Brass  
**Ottone Naturale** / Natural Brass  
**Brunito** / Burnished  
**Fumé** / Fumé

**Solo / Only H 1004 F RS**  
**Oro Lucido/Orsatin** / Polished Brass/Satin Brass

**H 1004 F RS**  
**Movimento F RS**  
**4 scatti**  
 Movement  
 4 click positions

Maniglia per Porta / Door Handle Pg. 66

# H 1003

Serie CROCO / design Matteo Thun

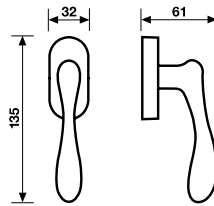
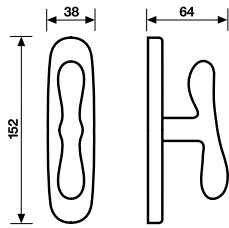

**H 1003 F**  
**Movimenti**  
Movements  
Gratz  
Gratz CP  
Gratz/7  
Martellina

**H 1003 F RS**  
**Movimento F RS**  
**4 scatti**  
Movement  
4 click positions

**Ottone** / Brass

**Oro Lucido** / Polished Brass  
**Orsatin** / Satin Brass  
**Cromsatin** / Satin Chrome  
**Anticato** / Antique

**Solo** / Only **H 1003 F RS**

**Oro Lucido/Orsatin** / Polished Brass/Satin Brass  
**Cromo/Cromsatin** / Chrome/Satin Chrome

Maniglia per Porta / Door Handle Pg. 68



# H 1000

Serie ANGELICA / design Valli Workshop

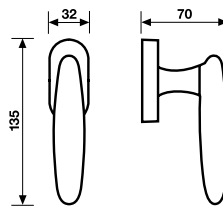
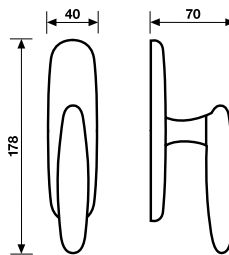

**H 1000 F**  
**Movimenti**  
Movements  
Gratz  
Gratz CP  
Gratz/7  
Martellina

**H 1000 F RS**  
**Movimento F RS**  
**4 scatti**  
Movement  
4 click positions

**Ottone e Vetro di Murano** / Brass and Murano glass

**Oro Lucido/Trasparente** / Polished Brass/Transparent  
**Oro Lucido/Trasparente Opaco** / Polished Brass/Matt Transparent  
**Cromatt/Trasparente Opaco** / Matt Chrome/Matt Transparent

Maniglia per Porta / Door Handle Pg. 70



# H 914/8

Serie MEDICEA / design Pasquale Valli

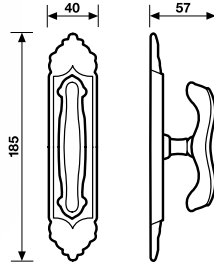

**H 914 F**  
**Movimenti**  
 Movements  
 Gratz  
 Gratz CP  
 Gratz/7  
 Martellina

**Ottone** / Brass

**Patiné** / Patiné

Maniglia per Porta / Door Handle Pg. 72

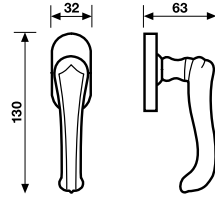

**H 914 F RS**  
**Movimento F RS**  
**4 scatti**  
 Movement  
 4 click positions

# H 227

Serie RIGEL / design Valli Workshop

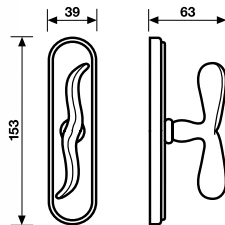

**H 227 F**  
**Movimenti**  
 Movements  
 Gratz  
 Gratz CP  
 Gratz/7  
 Martellina

**Nikrall Lega Zama UNI 3717** / Nikrall Zamak Alloy UNI 3717

**Orolux** / Brass Plated  
**Anticato** / Antique

Maniglia per Porta / Door Handle Pg. 74

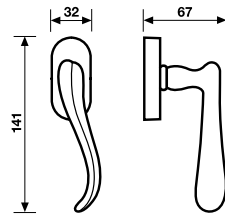

**H 227 F RS**  
**Movimento F RS**  
**4 scatti**  
 Movement  
 4 click positions

# H 198

Serie MIZAR / design Eero Aarnio

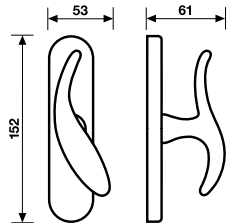

## H 198 F

### Movimenti

Movements  
Gratz  
Gratz CP  
Gratz/7  
Martellina

Ottone / Brass

Oro Lucido / Polished Brass

Orsatin / Satin Brass

Cromo / Chrome

Cromsatin / Satin Chrome

Anticato / Antique

Maniglia per Porta / Door Handle Pg. 76

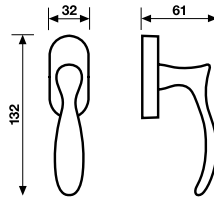

## H 198 F RS

### Movimento F RS

#### 4 scatti

Movement  
4 click positions



# H 196

Serie ULISSE L / design Cozza e Mascheroni

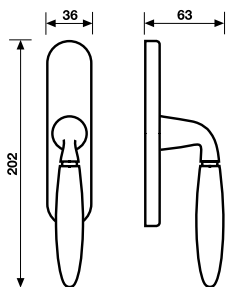

## H 196 F

### Movimenti

Movements  
Gratz  
Gratz CP  
Gratz/7  
Martellina

Ottone / Brass

Oro Lucido/Ormatt / Polished Brass/Matt Brass

Cromo/Cromsatin / Chrome/Satin Chrome

Maniglia per Porta / Door Handle Pg. 78

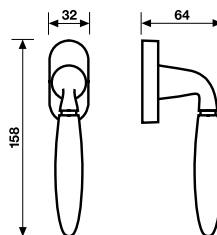

## H 196 F RS

### Movimento F RS

#### 4 scatti

Movement  
4 click positions





# H 195

Serie ORCHIDEA / design Valli Workshop

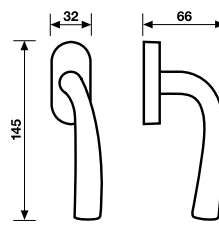
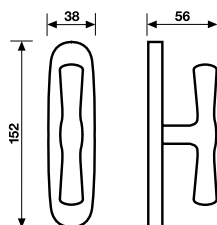

**H 195 F**  
**Movimenti**  
 Movements  
 Gratz  
 Gratz CP  
 Gratz/7  
 Martellina

**H 195 F RS**  
**Movimento F RS**  
**4 scatti**  
 Movement  
 4 click positions

**Ottone** / Brass

**Oro Lucido** / Polished Brass

**Cromsatin** / Satin Chrome

**Zirtanio Oro Lucido** / Zirtanio-coated Polished Brass



Maniglia per Porta / Door Handle Pg. 80

# H 192

Serie PRUNUS / design Valli Workshop

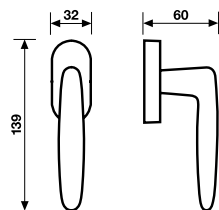
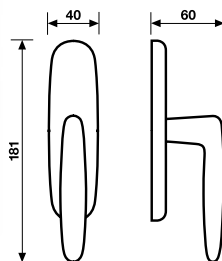

**H 192 F**  
**Movimenti**  
 Movements  
 Gratz  
 Gratz CP  
 Gratz/7  
 Martellina

**H 192 F RS**  
**Movimento F RS**  
**4 scatti**  
 Movement  
 4 click positions

**Ottone** / Brass

**Oro Lucido** / Polished Brass

**Nikmatt** / Nikmatt

Maniglia per Porta / Door Handle Pg. 82

# H 179

Serie AIDA / design Matteo Thun

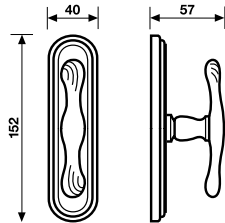

## H 179 F

### Movimenti

Movements  
Gratz  
Gratz CP  
Gratz/7  
Martellina

Ottone / Brass

Oro Lucido / Polished Brass

Maniglia per Porta / Door Handle Pg. 84

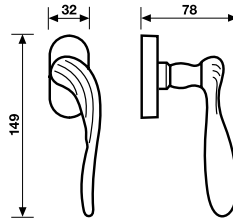

## H 179 F RS

### Movimento F RS

4 scatti  
Movement  
4 click positions



# H 176

Serie SPIGA / design Valli Workshop

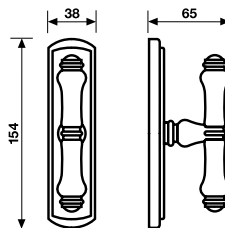

## H 176 F

### Movimenti

Movements  
Gratz  
Gratz CP  
Gratz/7  
Martellina

Ottone / Brass

Bianco/Oro Lucido / White/Polished Brass

Fiorato/Oro Lucido / Floral/Polished Brass

Brunito/Avorio / Burnished/Ivory

Brunito/Fiorato / Burnished/Floral

Maniglia per Porta / Door Handle Pg. 86

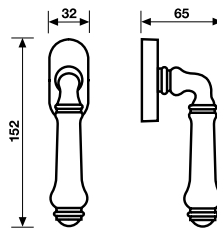

## H 176 F RS

### Movimento F RS

4 scatti  
Movement  
4 click positions



# H 174

Serie ALTAIR / design Valli Workshop

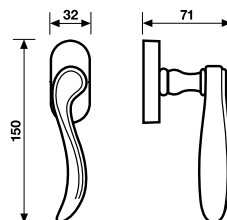
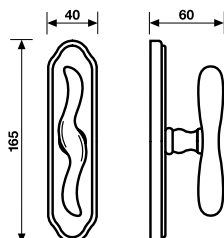

**H 174 F**  
**Movimenti**  
 Movements  
 Gratz  
 Gratz CP  
 Gratz/7  
 Martellina

**Ottone** / Brass

**Oro Lucido** / Polished Brass

**H 174 F RS**  
**Movimento F RS**  
**4 scatti**  
 Movement  
 4 click positions

Maniglia per Porta / Door Handle Pg. 88

# H 165

Serie GERMANA / design Valli Workshop

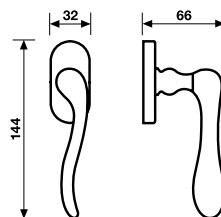
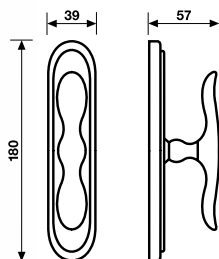

**H 165 F**  
**Movimenti**  
 Movements  
 Gratz  
 Gratz CP  
 Gratz/7  
 Martellina

**Ottone** / Brass

**Oro Lucido** / Polished Brass

**Orsatin** / Satin Brass

**Anticato** / Antique

**H 165 F RS**  
**Movimento F RS**  
**4 scatti**  
 Movement  
 4 click positions

Maniglia per Porta / Door Handle Pg. 90

# H 163

Serie SARISSA / design Valli Workshop

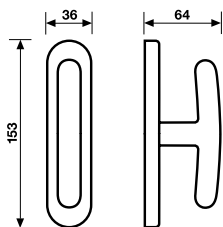

**H 163 F**  
**Movimenti**  
Movements  
Gratz  
Gratz CP  
Gratz/7  
Martellina

**Ottone** / Brass

**Oro Lucido** / Polished Brass

**Cromo** / Chrome

**Cromsatin** / Satin Chrome

Maniglia per Porta / Door Handle Pg. 92

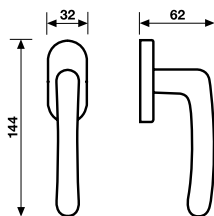

**H 163 F RS**  
**Movimento F RS**  
**4 scatti**  
Movement  
4 click positions





# K 1165

design Valli Workshop

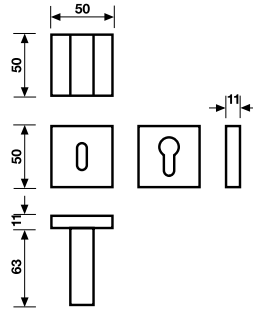

**K 1165 R8, K 1165 R8 Y**

**Nikrall Lega Zama UNI 3717** / Nikrall Zamak Alloy UNI 3717

**Orolux** / Polished Brass

**Cromo** / Chrome

**Cromsatin/Cromo** / Satin Chrome/Chrome

**Bocchette** / Escutcheons K 1138 - K 1138 Y Pg. 136

# K 1162

design Valli Workshop

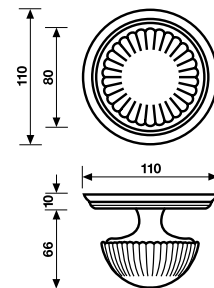
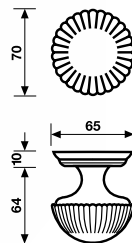

**K 1162 mis.A**

**K 1162 mis.80**

**Ottone** / Brass

**Oro Lucido** / Polished Brass

**Anticato** / Antique

**Brunito** / Burnished

**Zirtanio Oro Lucido** / Zirtanio-coated Polished Brass



Dispositivi di fissaggio da ordinare a parte /  
Fixings to be ordered separately Pg. 298

# K 1160

design Valli Workshop

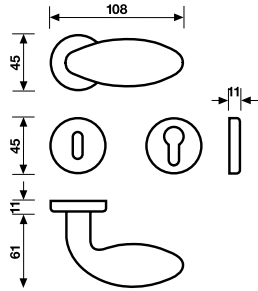

**K 1160 R8, K 1160 R8 Y**

**Ottone** / Brass

**Oro Lucido** / Polished Brass

**Ottone Naturale** / Natural Brass

**Cromsatin** / Satin Chrome

**Zirtanio Oro Lucido** / Zirtanio-coated Polished Brass

ZIRTANIO

Bocchette / Escutcheons K 1112 - K 1112 Y Pg. 142



# K 1155

design Valli Workshop

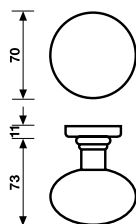

**K 1155 mis.A**

**Ottone** / Brass

**Oro Lucido** / Polished Brass

**Orsatin** / Satin Brass

**Cromo** / Chrome

**Cromsatin** / Satin Chrome

**Anticato** / Antique

**Brunito** / Burnished

**Solo** / Only K 1155 mis.A

**Zirtanio Oro Lucido** / Zirtanio-coated Polished Brass

ZIRTANIO

**Solo** / Only K 1155 R8, K 1155 R8 Y

**Ottone Naturale** / Natural Brass

Dispositivi di fissaggio da ordinare a parte /  
Fixings to be ordered separately Pg. 298

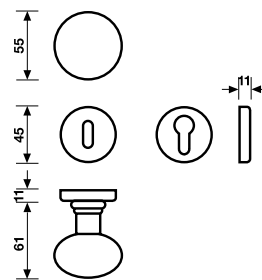

**K 1155 R8, K 1155 R8 Y**



# K 1153

design Valli Workshop

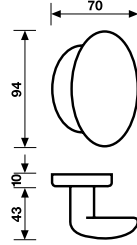
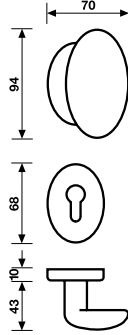

## K 1153 R Y

## K 1153 R SB

Ottone / Brass

Oro Lucido / Polished Brass

Cromsatin / Satin Chrome

Solo / Only K 1153 R Y

Zirtanio Oro Lucido / Zirtanio-coated Polished Brass



Bocchette / Escutcheons K 1132 Y Pg. 138. Dispositivi di fissaggio da ordinare a parte / Fixings to be ordered separately Pg. 299

# K 1153 PY

design Valli Workshop

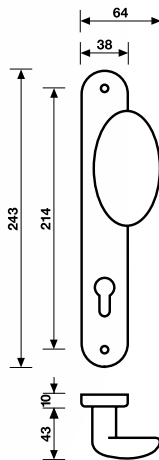

## K 1153 PY D 85, K 1153 PY S 85

Ottone / Brass

Oro Lucido / Polished Brass

# K 140

design Valli Workshop

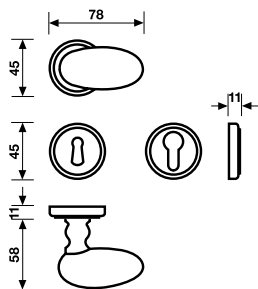

**K 140 R8, K 140 R8 Y**

**Ottone** / Brass

**Oro Lucido** / Polished Brass

Bocchette / Escutcheons K 1110 - K 1110 Y Pg. 142

# K 121

design Valli Workshop

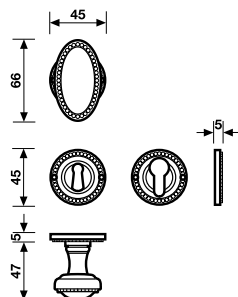

**K 121 R8, K 121 R8 Y**

**Ottone** / Brass

**Oro Lucido** / Polished Brass

**Ottone Naturale Antico** / Antique Natural Brass

Bocchette / Escutcheons K 195 - K 195 Y Pg. 144





# K 120

design Valli Workshop

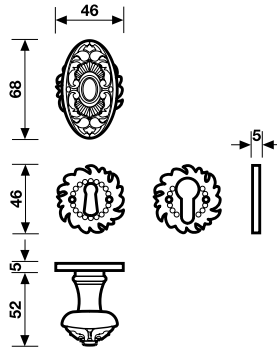

**K 120 R8, K 120 R8 Y**

**Ottone** / Brass

**Oro Lucido** / Polished Brass

**Ottone Naturale Antico** / Antique Natural Brass

**Bocchette** / Escutcheons K 194 - K 194 Y Pg. 144



# K 1228

design Yoshimi Kono

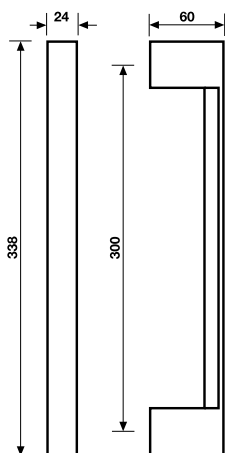

**K 1228**  
Interasse 300 mm  
Centre Distance

**Ottone** / Brass

**Cromo** / Chrome

**Cromsatin/Cromo** / Satin Chrome/Chrome

**Orolux** / Brass Plated

Dispositivi di fissaggio da ordinare a parte /  
Fixings to be ordered separately Pg. 294



# K 1227

design Gabriele e Oscar Buratti

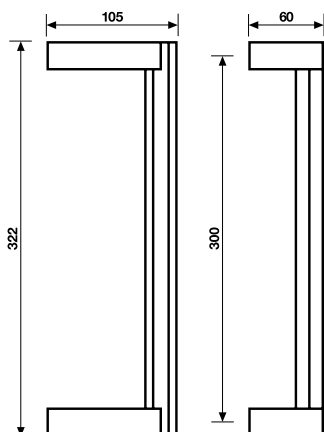

**K 1227**  
Interasse 300 mm  
Centre Distance

**Ottone** / Brass

**Cromo** / Chrome

**Cromsatin** / Satin Chrome

**Bronzsat** / Satin Bronze

**Zirtanio Oro Lucido** / Zirtanio-coated Polished Brass

ZIRTANIO

Dispositivi di fissaggio da ordinare a parte /  
Fixings to be ordered separately Pg. 294



# K 1226

design Jean-Baptiste Sibertin Blanc

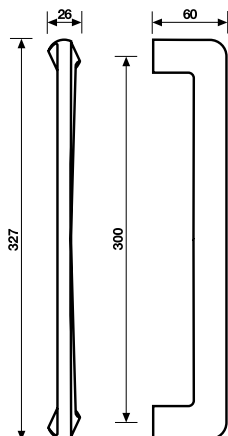

**K 1226**  
**Interasse 300 mm**  
 Centre Distance

**Ottone / Brass**

**Oro Lucido / Polished Brass**  
**Cromsatin/Cromo / Satin Chrome/Chrome**

Dispositivi di fissaggio da ordinare a parte /  
 Fixings to be ordered separately Pg. 294

# K 1218

design Gensler Associates International

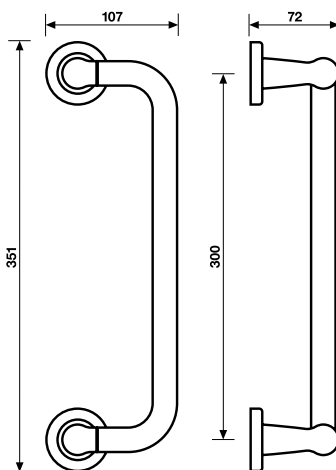

**K 1218**  
**Interasse 300 mm**  
 Centre Distance

**Ottone / Brass**

**Orsatin / Cromsatin**  
**Cromsatin / Satin Chrome**

Possibilità di montaggio senza rosette coprivite. Dispositivi di fissaggio da ordinare a parte / Possibility of mounting without cover-nut rosettes. Fixings to be ordered separately Pg. 294

# K 1216

design Studio Carlesi Design

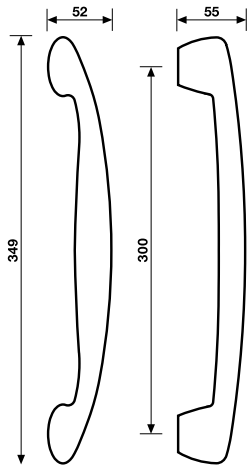

**K 1216**  
**Interasse 300 mm**  
Centre Distance

**Ottone** / Brass

**Oro Lucido** / Polished Brass

**Cromsatin** / Satin Chrome

**Zirtanio Oro Lucido** / Zirtanio-coated Polished Brass

**ZIRTANIO**

Dispositivi di fissaggio da ordinare a parte /  
Fixings to be ordered separately Pg. 294



# K 1210

design Eero Aarnio

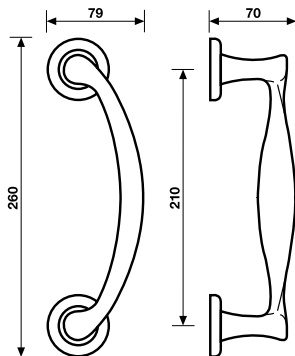

**K 1210**  
**Interasse 210 mm**  
Centre Distance

**Ottone** / Brass

**Oro Lucido** / Polished Brass

**Orsatin** / Satin Brass

**Cromsatin** / Satin Chrome

**Anticato** / Anticato

**Zirtanio Oro Lucido** / Zirtanio-coated Polished Brass

**ZIRTANIO**

Possibilità di montaggio senza rosette coprivite. Dispositivi di fissaggio  
da ordinare a parte / Possibility of mounting without cover-nut rosettes.  
Fixings to be ordered separately Pg. 294



# K 1209

design Valli Workshop

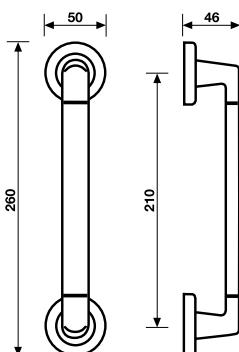

**K 1209**  
**Interasse 210 mm**  
 Centre Distance

**Ottone e Nikrall Lega Zama UNI 3717**  
 Brass and Nikrall Zamak Alloy UNI 3717

**Orolux/Orsatin** / Brass Plated/Satin Brass  
**Cromo/Cromsatin** / Chrome/Satin Chrome  
**Cromsatin** / Satin Chrome

Possibilità di montaggio senza rosette coprivite. Dispositivi di fissaggio da ordinare a parte / Possibility of mounting without cover-nut rosettes. Fixings to be ordered separately Pg. 294

# K 1207

design Valli Workshop

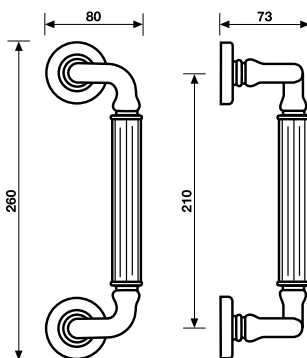

**K 1207**  
**Interasse 210 mm**  
 Centre Distance

**Ottone** / Brass

**Oro Lucido** / Polished Brass  
**Anticato** / Antique  
**Zirtanio Oro Lucido** / Zirtanio-coated Polished Brass



Dispositivi di fissaggio da ordinare a parte / Fixings to be ordered separately Pg. 296

# K 1188

design Valli Workshop

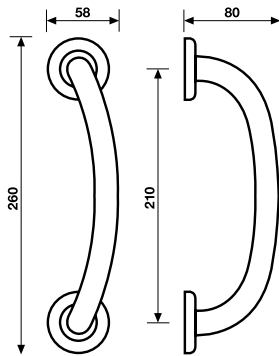

**K 1188**  
**Interasse 210 mm**  
Centre Distance

**Ottone** / Brass

**Oro Lucido** / Polished Brass

**Orsatin** / Satin Brass

**Cromsatin** / Satin Chrome

**Brunito** / Burnished

**Zirtanio Oro Lucido** / Zirtanio-coated Polished Brass

**ZIRTANIO**

Dispositivi di fissaggio da ordinare a parte /  
Fixings to be ordered separately Pg. 296



# K 1181

design Matteo Thun

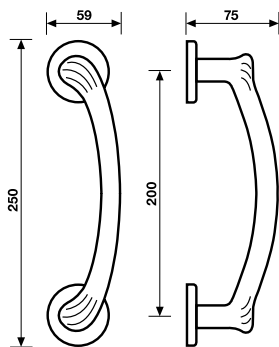

**K 1181**  
**Interasse 210 mm**  
Centre Distance

**Ottone** / Brass

**Oro Lucido** / Polished Brass

Dispositivi di fissaggio da ordinare a parte /  
Fixings to be ordered separately Pg. 296



# K 169

design Yoshimi Kono

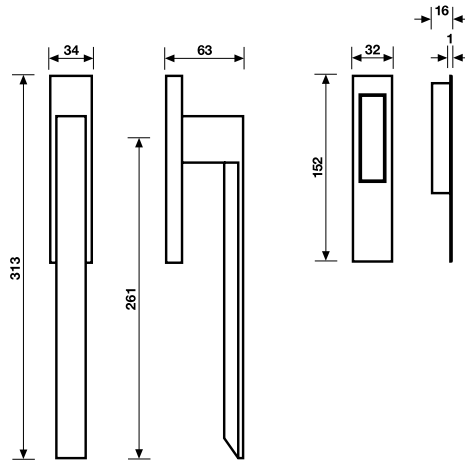

**K 169**  
Interasse 261 mm  
Centre Distance

Ottone / Brass

Orolux / Brass Plated

Cromo / Chrome

Cromsatin/Cromo / Satin Chrome/Chrome

**K 169 Y**  
Interasse 261 mm  
Centre Distance

L'articolo K 169 Y viene venduto senza la maniglia di trascinamento /  
The article K 169 Y is sold without the recessed finger pull

# K 168

design Valli Workshop

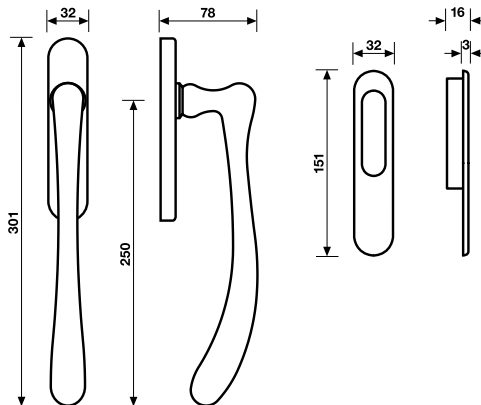

**K 168**  
Interasse 250 mm  
Centre Distance

Ottone / Brass

Oro Lucido / Polished Brass

Brunito / Burnished

**K 168 Y**  
Interasse 250 mm  
Centre Distance

L'articolo K 168 Y viene venduto senza la maniglia di trascinamento /  
The article K 168 Y is sold without the recessed finger pull

# K 163

design Valli Workshop

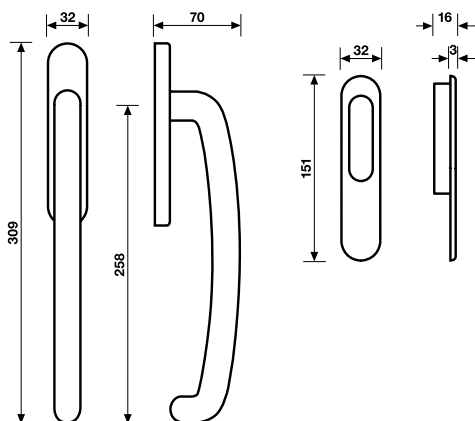

**K 163**  
**Interasse 258 mm**  
Centre Distance

**K 163 Y**  
**Interasse 258 mm**  
Centre Distance

**Ottone** / Brass

**Oro Lucido** / Polished Brass

**Ottone Naturale** / Natural Brass

**Cromsatin** / Satin Chrome

**Brunito** / Burnished

L'articolo K 163 Y viene venduto senza la maniglia di trascimento /  
The article K 163 Y is sold without the recessed finger pull







## K 1139

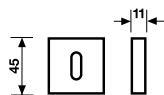

**K 1139**  
**Bocchetta foro normale**  
 Standard hole escutcheon

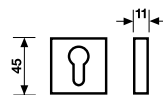

**K 1139 Y**  
**Bocchetta foro cilindro**  
 Euro-profile hole escutcheon

**Nikrall Lega Zama UNI 3717** / Nikrall Zamak Alloy UNI 3717

**Cromo** / Chrome  
**Cromsatin** / Satin Chrome

## K 1138



**K 1138**  
**Bocchetta foro normale**  
 Standard hole escutcheon

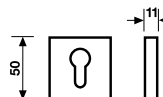

**K 1138 Y**  
**Bocchetta foro cilindro**  
 Euro-profile hole escutcheon

**Ottone** / Brass

**Orolux** / Brass Plated  
**Cromo** / Chrome  
**Cromsatin** / Satin Chrome  
**Bronzsat** / Satin Bronze  
**Zirtanio Oro Lucido** / Zirtanio-coated Polished Brass

**ZIRTANIO**

## K 1141

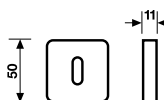

**K 1141**  
**Bocchetta foro normale**  
 Standard hole escutcheon



**K 1141 Y**  
**Bocchetta foro cilindro**  
 Euro-profile hole escutcheon

**Ottone** / Brass

Assegnata alla serie **Orione H 1048** / Assigned to series H 1048

# K 1135

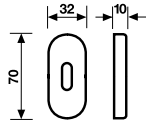

**K 1135**  
**Bocchetta stretta**  
**foro normale**  
 Narrow standard  
 hole escutcheon

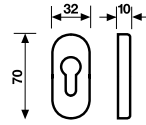

**K 1135 Y**  
**Bocchetta stretta**  
**foro cilindro**  
 Narrow Euro-profile  
 hole escutcheon

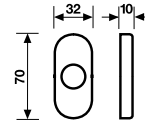

**K 1135 RS**  
**Rosetta stretta**  
 Narrow rosette

**Ottone** / Brass

**Oro Lucido** / Polished Brass

**Orsatin** / Satin Brass

**Ottone Naturale** / Natural Brass

**Cromo** / Chrome

**Cromsatin** / Satin Chrome

**Anticato** / Antique

**Brunito** / Burnished

**Fumé** / Fumé

**Zirtanio Oro Lucido** / Zirtanio-coated Polished Brass



# K 1134



**K 1134**  
**Bocchetta foro normale**  
 Standard hole escutcheon

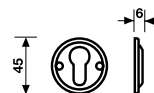

**K 1134 Y**  
**Bocchetta foro cilindro**  
 Euro-profile hole escutcheon

**Ottone** / Brass

**Oro Lucido** / Polished Brass

**Ottone Naturale** / Natural Brass

**Brunito** / Burnished



# K 1132

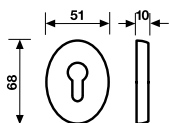

**K 1132 Y**  
**Bocchetta foro cilindro**  
 Euro-profile hole escutcheon

**Ottone** / Brass

**Ormatt** / Matt Brass

**Cromsatin** / Satin Chrome

**Oro Lucido** / Polished Brass

# K 1131

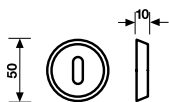

**K 1131**  
**Bocchetta foro normale**  
 Standard hole escutcheon

**Ottone** / Brass

**Oro Lucido** / Polished Brass

**Cromo** / Chrome

**Cromsatin** / Satin Chrome

**Zirtanio Oro Lucido** / Zirtanio-coated Polished Brass

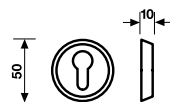

**K 1131 Y**  
**Bocchetta foro cilindro**  
 Euro-profile hole escutcheon

# K 1128

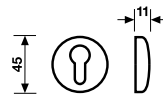
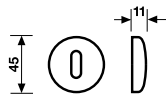

**K 1128**  
**Bocchetta foro normale**  
Standard hole escutcheon

**K 1128 Y**  
**Bocchetta foro cilindro**  
Euro-profile hole escutcheon

**Ottone** / Brass

**Oro Lucido** / Polished Brass

**Cromatt** / Matt Chrome

**Nikmatt** / Nikmatt



# K 1125

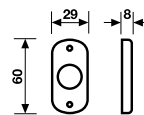
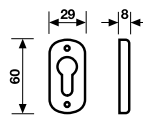
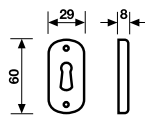

**K 1125**  
**Bocchetta stretta foro normale**  
Narrow standard hole escutcheon

**K 1125 Y**  
**Bocchetta stretta foro cilindro**  
Narrow Euro-profile hole escutcheon

**K 1125 RS**  
**Rosetta stretta**  
Narrow rosette

**Ottone** / Brass

**Oro Lucido** / Polished Brass

**Ottone Naturale** / Natural Brass

**Brunito** / Burnished

**Fumé** / Fumé



# K 1121

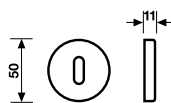

**K 1121**  
**Bocchetta foro normale**  
 Standard hole escutcheon

**Ottone** / Brass

**Oro Lucido** / Polished Brass

**Orolux** / Brass Plated

**Cromo** / Chrome

**Cromsatin** / Satin Chrome



**K 1121 Y**  
**Bocchetta foro cilindro**  
 Euro-profile hole escutcheon

# K 1120

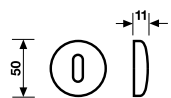

**K 1120**  
**Bocchetta foro normale**  
 Standard hole escutcheon

**Ottone** / Brass

**Oro Lucido** / Polished Brass

**Orsatin** / Satin Brass

**Cromsatin** / Satin Chrome

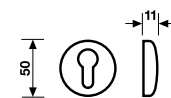

**K 1120 Y**  
**Bocchetta foro cilindro**  
 Euro-profile hole escutcheon

# K 1119

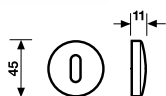

**K 1119**  
**Bocchetta foro normale**  
Standard hole escutcheon

**Ottone** / Brass

**Oro Lucido** / Polished Brass

**Orsatin** / Satin Brass

**Cromo** / Chrome

**Cromsatin** / Satin Chrome

**Anticato** / Antique

**Zirtanio Oro Lucido** / Zirtanio-coated Polished Brass

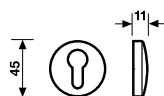

**K 1119 Y**  
**Bocchetta foro cilindro**  
Euro-profile hole escutcheon



# K 1115

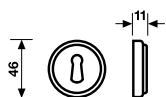

**K 1115**  
**Bocchetta foro normale**  
Standard hole escutcheon

**Ottone** / Brass

**Oro Lucido** / Polished Brass

**Ottone Naturale** / Natural Brass

**Ottone Naturale Antico** / Antique Natural Brass

**Brunito** / Burnished

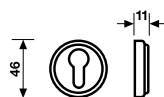

**K 1115 Y**  
**Bocchetta foro cilindro**  
Euro-profile hole escutcheon



# K 1112

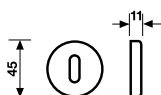

**K 1112**  
**Bocchetta foro normale**  
 Standard hole escutcheon

**Ottone** / Brass

**Oro Lucido** / Polished Brass  
**Orolux** / Brass Plated  
**Orsatin** / Satin Brass  
**Ottone Naturale** / Natural Brass  
**Cromo** / Chrome  
**Cromsatin** / Satin Chrome  
**Anticato** / Antique  
**Brunito** / Burnished

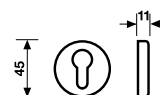

**K 1112 Y**  
**Bocchetta foro cilindro**  
 Euro-profile hole escutcheon

# K 1110



**K 1110**  
**Bocchetta foro normale**  
 Standard hole escutcheon

**Ottone** / Brass

**Oro Lucido** / Polished Brass  
**Orsatin** / Satin Brass  
**Ottone Naturale** / Natural Brass  
**Anticato** / Antique  
**Brunito** / Burnished  
**Fumé** / Fumé

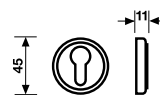

**K 1110 Y**  
**Bocchetta foro cilindro**  
 Euro-profile hole escutcheon

# K 915

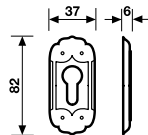
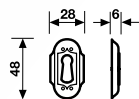

**K 915**  
**Bocchetta foro normale**  
Standard hole escutcheon

**Ottone** / Brass

**Patiné** / Patiné

**K 915 Y**  
**Bocchetta foro cilindro**  
Euro-profile hole escutcheon



# K 292

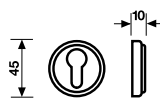
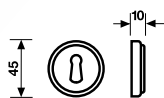

**K 292**  
**Bocchetta foro normale**  
Standard hole escutcheon

**Nikrall Lega Zama UNI 3717** / Nikrall Zamak Alloy UNI 3717

**Orolux** / Brass Plated  
**Anticato** / Antique

**K 292 Y**  
**Bocchetta foro cilindro**  
Euro-profile hole escutcheon





# K 195



**K 195**  
**Bocchetta foro normale**  
 Standard hole escutcheon

Ottone / Brass

Oro Lucido / Polished Brass  
 Ottone Naturale Antico / Antique Natural Brass

Serie Luigi XVI Pg. 34



**K 195 Y**  
**Bocchetta foro cilindro**  
 Euro-profile hole escutcheon

# K 194

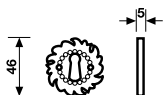

**K 194**  
**Bocchetta foro normale**  
 Standard hole escutcheon

Ottone / Brass

Oro Lucido / Polished Brass  
 Ottone Naturale Antico / Antique Natural Brass

Serie Luigi XV Pg. 36



**K 194 Y**  
**Bocchetta foro cilindro**  
 Euro-profile hole escutcheon

# K 1136 PL

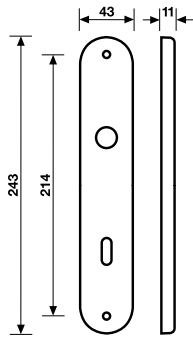

**K 1136 PL 70-90**  
**Placca foro normale**  
Door handle plate, standard hole

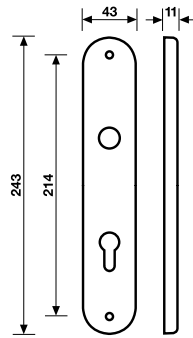

**K 1136 PL Y 85**  
**Placca foro cilindro**  
Euro-profile hole

**Ottone** / Brass

- Oro Lucido** / Polished Brass
- Orsatin** / Satin Brass
- Ottone Naturale** / Natural Brass
- Cromo** / Chrome
- Cromsatin** / Satin Chrome
- Anticato** / Antique
- Brunito** / Burnished

Idonea anche per il nuovo sistema di montaggio con molla separata/  
Suitable also for use with the new fixing system with separate spring



# K 1125 PL

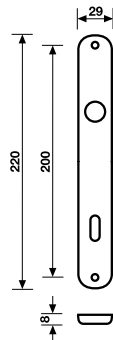

**K 1125 PL 70-90**  
**Placca stretta foro normale**  
Narrow plate, standard hole

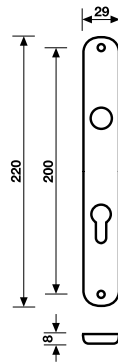

**K 1125 PL Y 85**  
**Placca stretta foro cilindro**  
Narrow plate, Euro-profile hole

**Ottone** / Brass

- Oro Lucido** / Polished Brass
- Cromsatin** / Satin Chrome



Valli&amp;Valli

## K 1013 PL FG

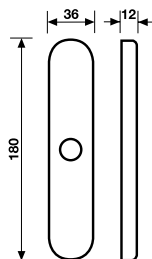

### K 1013 PL FG

**Placca separata per maniglia per finestre utilizzabile con qualsiasi nostra impugnatura finestra**

Window handle plate suitable for use with any of our window handles

**Ottone** / Brass

**Oro Lucido** / Polished Brass

**Ottone Naturale** / Natural Brass

**Cromsatin** / Satin Chrome

**Anticato** / Antique

**Brunito** / Burnished

## K 1751 PLF SER-41

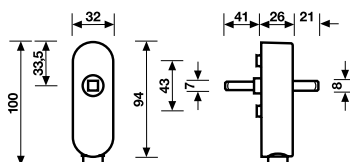

### K 1751 PLF SER-41

**Movimento 4 scatti completo di rosetta e serratura di sicurezza con chiave cifratura unica**

4 click positions movement complete of rosette and security lock with blank key

**Ottone** / Brass

**Oro Lucido** / Polished Brass

**Orsatin** / Satin Brass

**Cromo** / Chrome

**Cromsatin** / Satin Chrome

**Brunito** / Burnished

# K 1232

Serie BESS / design Yoshimi Kono

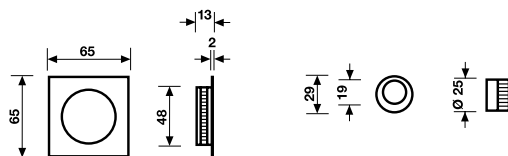
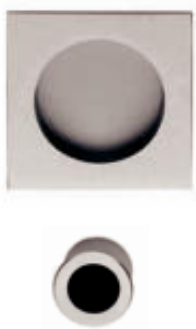

## K 1232

### Kit incasso completo di maniglia di trascinamento senza serratura

Inset handle kit with recessed finger pull, without lock

**Ottone** / Brass

**Orolux** / Brass Plated

**Cromo** / Chrome

**Cromsatin** / Satin Chrome



# K 1230

Serie BESS / design Yoshimi Kono

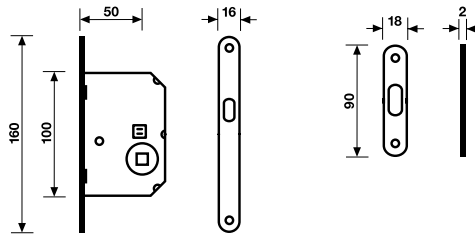
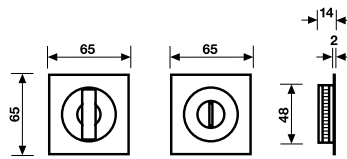

## K 1230

### Kit incasso con nottolino completo di serratura e maniglia di trascinamento

Inset handle kit with thumb turn complete with lock and recessed finger pull

**Ottone** / Brass

**Orolux** / Brass Plated

**Cromo** / Chrome

**Cromsatin** / Satin Chrome

# K 1212

Serie ORFEIDE / design Scrigno

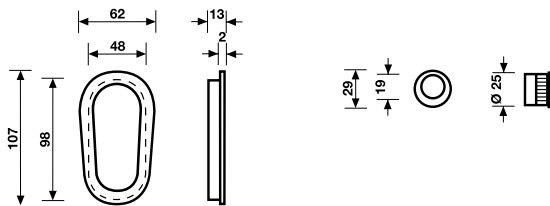

## K 1212

**Kit incasso completo di maniglia di trascinamento senza serratura**

Inset handle kit with recessed finger pull, without lock

**Ottone** / Brass

**Oro Lucido** / Polished Brass

**Orsatin** / Satin Brass

**Cromo** / Chrome

**Cromsatin** / Satin Chrome



# K 1211

Serie ORFEIDE / design Scrigno

K 1211

Maniglie per Incasso \ Inset Handles

150

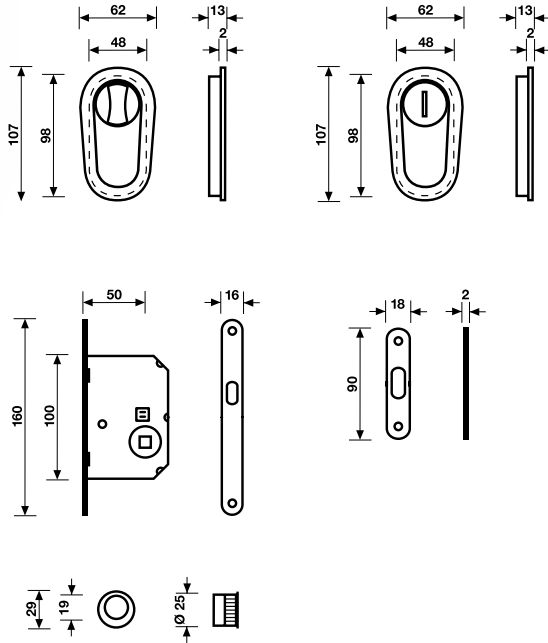

## K 1211

### Kit incasso con nottolino completo di serratura e maniglia di trascinamento

Inset handle kit with thumb turn complete with lock and recessed finger pull

Ottone / Brass

Oro Lucido / Polished Brass

Orsatin / Satin Brass

Cromo / Chrome

Cromsatin / Satin Chrome

# K 1206

Serie TANCREDI / design Valli Workshop

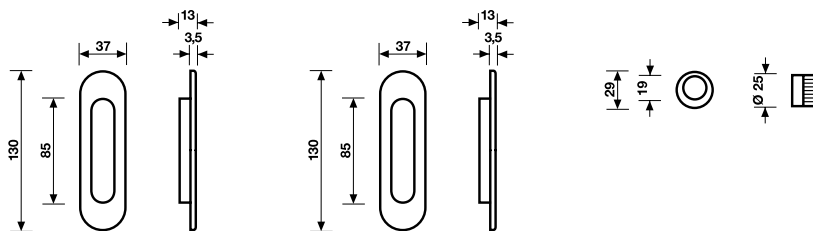

## K 1206

### Kit incasso completo di maniglia di trascinamento senza serratura

Inset handle kit with recessed finger pull, without lock

Ottone / Brass

Oro Lucido / Polished Brass

Orsatin / Satin Brass

Cromo / Chrome

Cromsatin / Satin Chrome

Anticato / Antique





# K 1205

Serie TANGREDI / design Valli Workshop

K 1205

Maniglie per Incasso \ Inset Handles

152

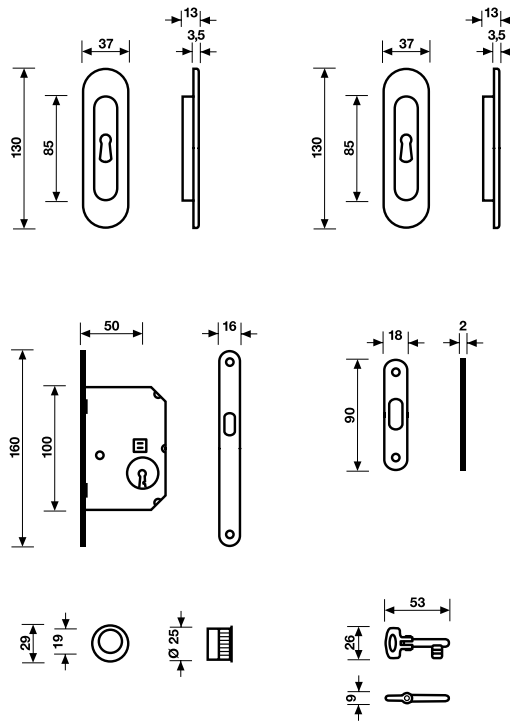
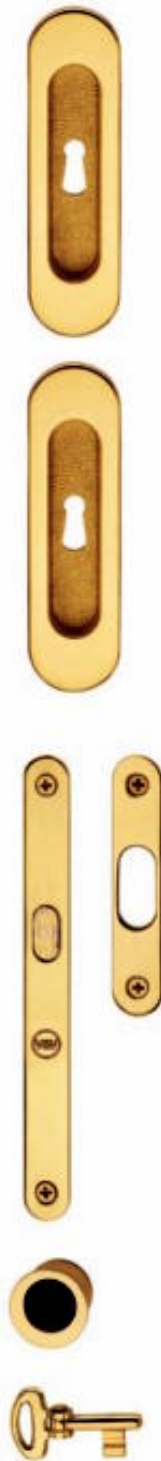

## K 1205

**Kit incasso con foro chiave completo di chiave snodata, serratura e maniglia di trascinamento**

Inset handle kit with key hole complete with jointed key, lock and recessed finger pull

**Ottone** / Brass

**Oro Lucido** / Polished Brass

**Orsatin** / Satin Brass

**Cromo** / Chrome

**Cromsatin** / Satin Chrome

**Anticato** / Antique

# K 1204

Serie TANCREDI / design Valli Workshop

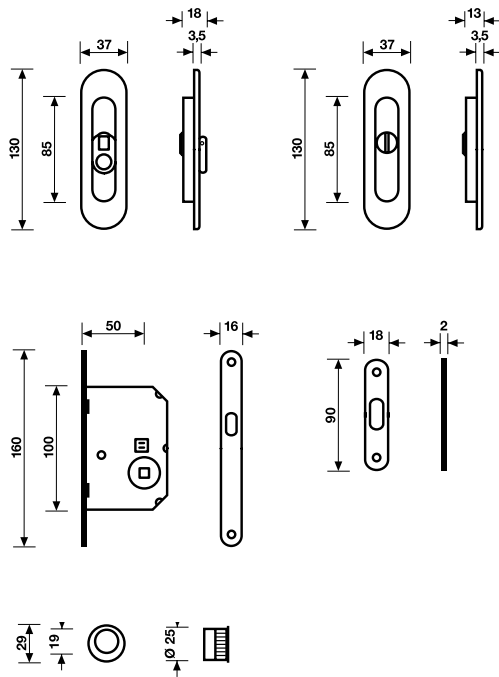

## K 1204

### Kit incasso con nottolino completo di serratura e maniglia di trascinamento

Inset handle kit with thumb turn complete with lock and recessed finger pull

**Ottone** / Brass

**Oro Lucido** / Polished Brass

**Orsatin** / Satin Brass

**Cromo** / Chrome

**Cromsatin** / Satin Chrome

**Anticato** / Antique





# K 1203

Serie TRITTICO / design Valli Workshop



**K 1203**  
**Maniglia di trascimento**  
 Recessed finger pull

**Ottone** / Brass

**Oro Lucido** / Polished Brass

**Orsatin** / Satin Brass

**Cromo** / Chrome

**Cromsatin** / Satin Chrome

**Anticato** / Antique

**Ottone Naturale** / Natural Brass

# K 1202

Serie TRITTICO / design Valli Workshop

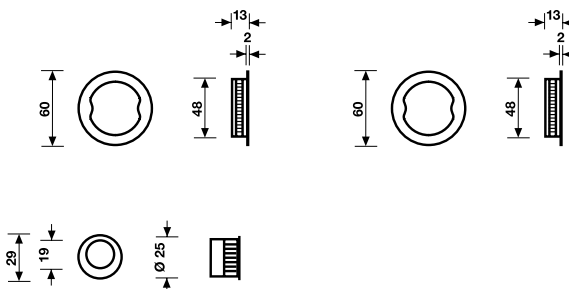

**K 1202**  
**Kit incasso completo di maniglia di trascimento senza serratura**  
 Inset handle kit with recessed finger pull, without lock

**Ottone** / Brass

**Oro Lucido** / Polished Brass

**Orsatin** / Satin Brass

**Cromo** / Chrome

**Cromsatin** / Satin Chrome

**Anticato** / Antique

**Ottone Naturale** / Natural Brass

# K 1201

Serie TRITTICO / design Valli Workshop

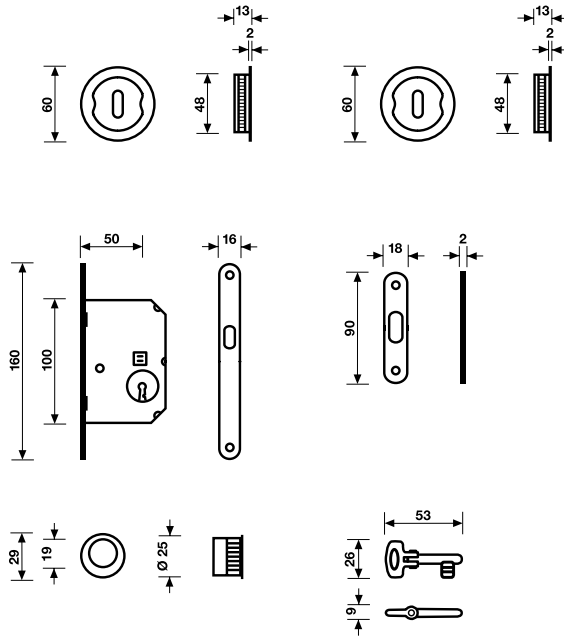

## K 1201

### Kit incasso con foro chiave completo di chiave snodata, serratura e maniglia di trascinamento

Inset handle kit with key hole complete with jointed key, lock and recessed finger pull

**Ottone** / Brass

**Oro Lucido** / Polished Brass

**Orsatin** / Satin Brass

**Cromo** / Chrome

**Cromsatin** / Satin Chrome

**Anticato** / Antique



# K 1200

Serie TRITTICO / design Valli Workshop

K 1200

Maniglie per Incasso \ Inset Handles

156

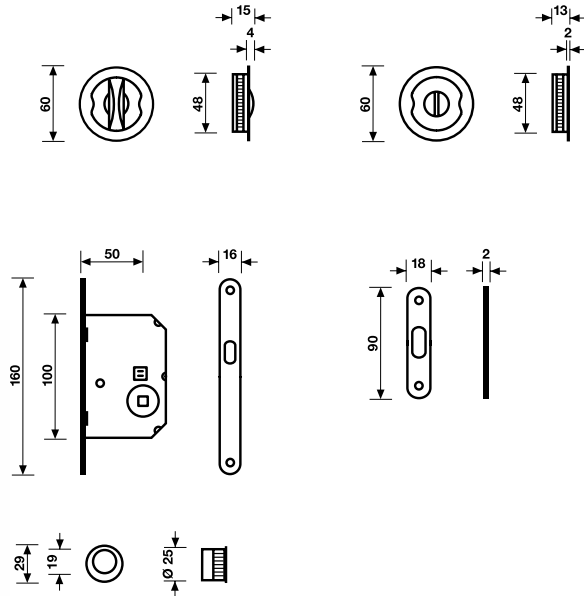

## K 1200

### Kit incasso con nottolino completo di serratura e maniglia di trascinamento

Inset handle kit with thumb turn complete with lock and recessed finger pull

**Ottone** / Brass

**Oro Lucido** / Polished Brass

**Orsatin** / Satin Brass

**Ottone Naturale** / Natural Brass

**Cromo** / Chrome

**Cromsatin** / Satin Chrome

**Anticato** / Antique

**Brunito** / Burnished

# K 1186

design Valli Workshop

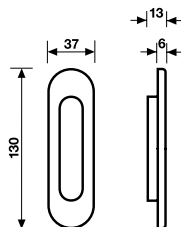
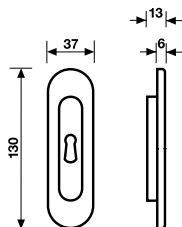

**K 1186**  
**Maniglie per incasso**  
Inset handle

**K 1186 SFC**  
**Maniglie per incasso**  
Inset handle

**Ottone** / Brass

**Oro Lucido** / Polished Brass

**Orsatin** / Satin Brass

**Ottone Naturale** / Natural Brass

**Cromo** / Chrome

**Cromsatin** / Satin Chrome

**Anticato** / Antique

**Nikmatt** / Nikmatt

**Brunito** / Burnished



# K 1195

design Valli Workshop

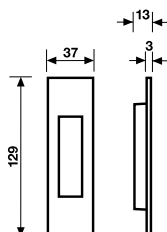
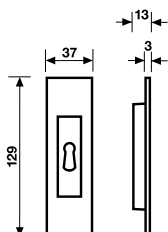

**K 1195**  
**Maniglie per incasso**  
Inset handle

**K 1195 SFC**  
**Maniglie per incasso**  
Inset handle

**Ottone** / Brass

**Oro Lucido** / Polished Brass

**Cromo** / Chrome

**Cromsatin** / Satin Chrome



# K 1740 R

design Valli Workshop

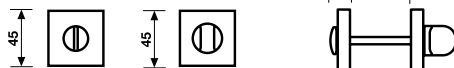

## K 1740 R6-7-8 BZG 85

**Chiusure privacy BZG**  
Bathroom privacy sets

**Ottone** / Brass

**Cromo** / Chrome

**Cromsatin** / Satin Chrome

# K 1704 R

design Valli Workshop



## K 1704 R6-7-8 BZG 85

**Chiusure privacy BZG**  
Bathroom privacy sets

**Ottone** / Brass

**Oro Lucido** / Polished Brass

**Orsatin** / Satin Brass

**Ottone Naturale** / Natural Brass

**Cromo** / Chrome

**Cromsatin** / Satin Chrome

**Anticato** / Antique

**Nikmatt** / Nikmatt

**Brunito** / Burnished

**Fumé** / Fumé

**Zirtanio Oro Lucido** / Zirtanio-coated Polished Brass

ZIRTANIO

# K 1229 R

## K 1229 R6-7-8 BZG

**Chiusure privacy BZG**  
Bathroom privacy sets

**Ottone** / Brass

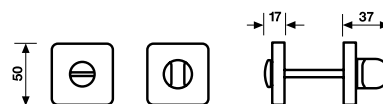

Assegnata alla serie Orione H 1048 / Assigned to series H 1048

# K 1704 RS

design Valli Workshop

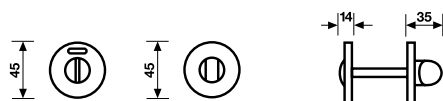

## K 1704 RS6-7-8 BZG 85

### Chiusure privacy BZG

Bathroom privacy sets

Ottone / Brass

Oro Lucido / Polished Brass

Cromo / Chrome

Cromsatin / Satin Chrome

Nikmatt / Nikmatt

Zirtanio Oro Lucido / Zirtanio-coated Polished Brass

ZIRTANIO



# K 1225 R

design Valli Workshop

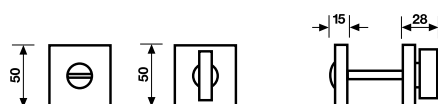

## K 1225 R6-7-8 BZG 85

### Chiusure privacy BZG

Bathroom privacy sets

Ottone / Brass

Orolux / Brass Plated

Cromo / Chrome

Cromsatin / Satin Chrome

Bronzsat / Satin Bronze

Zirtanio Oro Lucido / Zirtanio-coated Polished Brass

ZIRTANIO



# K 9018

design Valli Workshop



K 9018

Copridado\Nut Cover

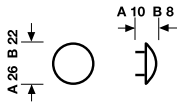

**K 9018**  
**Copridado**  
Nut Cover

**Nikrall Lega Zama UNI 3717** / Nikrall Zamak Alloy UNI 3717

**Fumé** / Fumé

# L 193

design Valli Workshop

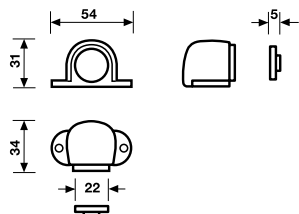

**L 193**  
**Fermaporta con calamita**  
Magnetic door stop

**Ottone** / Brass

**Oro Lucido** / Polished Brass

**Cromo** / Chrome

**Cromsatin** / Satin Chrome

**Anticato** / Antique



# L 190

design Valli Workshop



**L 190**  
**Fermaporta**  
Door stop

**Ottone** / Brass

**Oro Lucido** / Polished Brass

**Cromo** / Chrome

**Cromsatin** / Satin Chrome

**Brunito** / Burnished



Valli&Valli

# L 18

design Valli Workshop

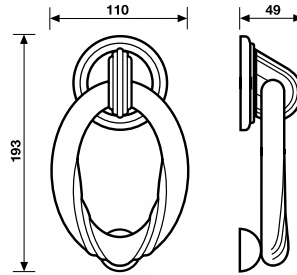

## L 18

### Battiporta

Door Knocker

Ottone / Brass

Oro Lucido / Polished Brass

Anticato / Antique

Zirtanio Oro Lucido / Zirtanio-coated Polished Brass



# L 17

design Valli Workshop

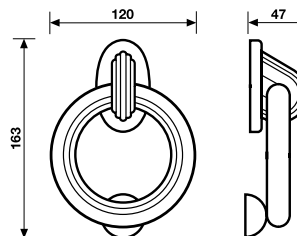

## L 17

### Battiporta

Door Knocker

Ottone / Brass

Oro Lucido / Polished Brass

Anticato / Antique

Zirtanio Oro Lucido / Zirtanio-coated Polished Brass



# M 1117

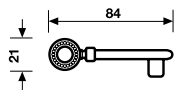

## M 1117

**Ottone** / Brass

**Oro Lucido** / Polished Brass

**Ottone Naturale Antico** / Antique Natural Brass

Serie Luigi XVI Pg. 34



# M 1116

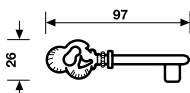

## M 1116

**Ottone** / Brass

**Oro Lucido** / Polished Brass

**Ottone Naturale Antico** / Antique Natural Brass

Serie Luigi XV Pg. 36



# M 1115

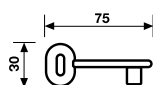

## M 1115

**Ottone** / Brass

**Oro Lucido** / Polished Brass

**Ottone Naturale** / Natural Brass

**Cromsatin** / Satin Chrome

**Brunito** / Burnished

# M 1112

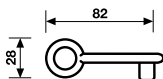

## M 1112

**Ottone** / Brass

**Oro Lucido** / Polished Brass

**Orsatin** / Satin Brass

**Orolux** / Brass Plated

**Cromo** / Chrome

**Cromsatin** / Satin Chrome

**Brunito** / Burnished

# M 1107

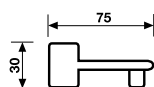

## M 1107

**Ottone** / Brass

**Orolux** / Brass Plated

**Cromo** / Chrome

**Cromsatin** / Satin Chrome

**Bronzsat** / Satin Bronze



# M 1101

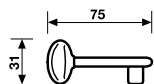

## M 1101

**Ottone** / Brass

**Oro Lucido** / Polished Brass

**Orsatin** / Satin Brass

**Ottone Naturale** / Natural Brass

**Ottone Naturale Antico** / Antique Natural Brass

**Cromo** / Chrome

**Cromsatin** / Satin Chrome

**Brunito** / Burnished

**Fumé** / Fumé



# M 194

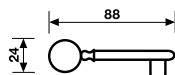

## M 194

**Ottone** / Brass

**Oro Lucido** / Polished Brass

**Orsatin** / Satin Brass

**Anticato** / Antique

# M 191

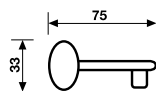

## M 191

**Ottone** / Brass

**Oro Lucido** / Polished Brass

**Orsatin** / Satin Brass

**Ottone Naturale** / Natural Brass

**Cromo** / Chrome

**Cromsatin** / Satin Chrome

**Anticato** / Antique

**Brunito** / Burnished

# N 121

design Valli Workshop

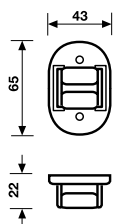

**N 121**  
**Copriavvolgitore**  
Coiler Cover

**Ottone** / Brass

**Oro Lucido** / Polished Brass  
**Cromsatin** / Satin Chrome



# N 120

design Valli Workshop

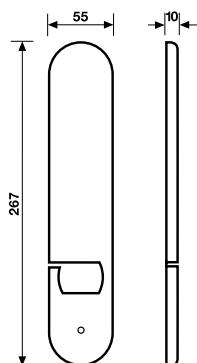

**N 120**  
**Copriavvolgitore**  
Coiler Cover

**Ottone** / Brass

**Oro Lucido** / Polished Brass  
**Cromsatin** / Satin Chrome  
**Anticato** / Antique  
**Brunito** / Burnished



# N 26

design Valli Workshop

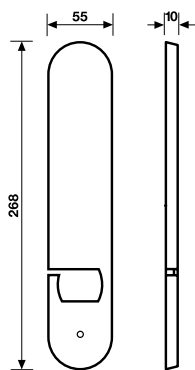

**N 121**  
**Copriavvolgitore**  
Coiler Cover

**Nikrall Lega Zama UNI 3717** / Nikrall Zamak Alloy UNI 3717

**Bianco** / White



# E 1020

design Valli Workshop

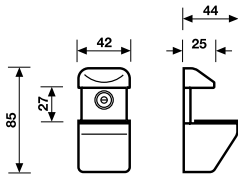

## E 1020

**Reggimensola**  
Shelf Brackets

**Spessori 4 ÷ 25**  
Thickness

**Nikrall Lega Zama UNI 3717** / Nikrall Zamak Alloy UNI 3717

**Orolux** / Brass Plated  
**Cromo** / Chrome  
**Cromsatin** / Satin Chrome



# E 1019

design Valli Workshop

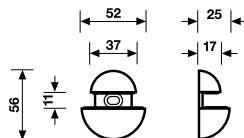

## E 1019

**Reggimensola**  
Shelf Brackets

**Spessori fino a 8**  
Thickness up to

**Nikrall Lega Zama UNI 3717** / Nikrall Zamak Alloy UNI 3717

**Orolux** / Brass Plated  
**Cromo** / Chrome  
**Cromsatin** / Satin Chrome



# E 1018

design Valli Workshop

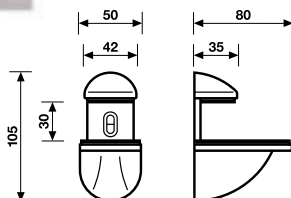

**E 1018**  
**Reggimensola**  
Shelf Brackets

**Spessori 5 ÷ 32**  
Thickness

**Nikrall Lega Zama UNI 3717** / Nikrall Zamak Alloy UNI 3717

**Orolux** / Brass Plated

**Cromo** / Chrome

**Cromsatin** / Satin Chrome

# E 1025

design Yoshimi Kono

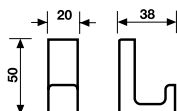

**E 1025**  
**Gancio**  
Hook

**Ottone** / Brass

**Orolux** / Brass Plated

**Cromo** / Chrome

**Cromsatin/Cromo** / Satin Chrome/Chrome

# E 1024

design Yoshimi Kono

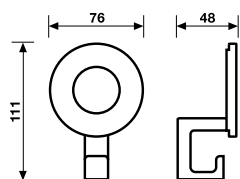

**E 1024**  
**Portabito**  
Coathook

**Ottone** / Brass

**Orolux** / Brass Plated

**Cromo** / Chrome

**Cromsatin/Cromo** / Satin Chrome/Chrome



# E 1021

design Gensler Associates International

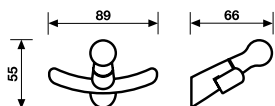

**E 1021**  
**Portabito**  
Coathook

**Ottone** / Brass

**Orsatin** / Satin Brass

**Cromsatin** / Satin Chrome

Serie Capriccio Pg. 40



# E 1011

design Valli Workshop

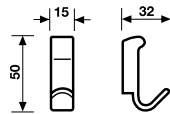

**E 1011**  
**Gancio**  
Hook

**Ottone** / Brass

**Oro Lucido** / Polished Plated

**Cromo** / Chrome

**Cromsatin** / Satin Chrome

# E 1009

design Valli Workshop

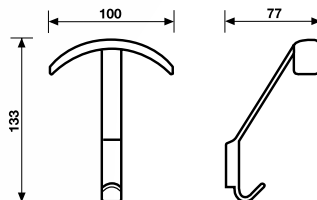

**E 1009**  
**Portabito**  
Coathook

**Ottone** / Brass

**Oro Lucido** / Polished Brass

**Cromsatin** / Satin Chrome

# E 525

design Valli Workshop

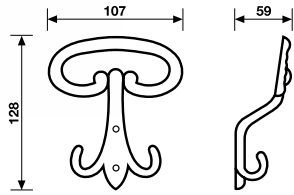

**E 525**  
**Portabito**  
Coathook

**Nikrall Lega Zama UNI 3717** / Nikrall Zamak Alloy UNI 3717

**Patiné** / Patiné  
**Fumé** / Fumé



# E 520

design Valli Workshop

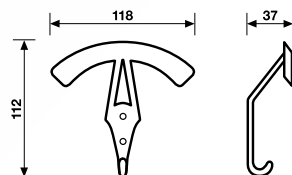

**E 520**  
**Portabito**  
Coathook

**Nikrall Lega Zama UNI 3717** / Nikrall Zamak Alloy UNI 3717

**Cromo** / Chrome  
**Nero** / Black



# E 231

design Valli Workshop

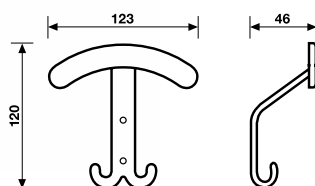
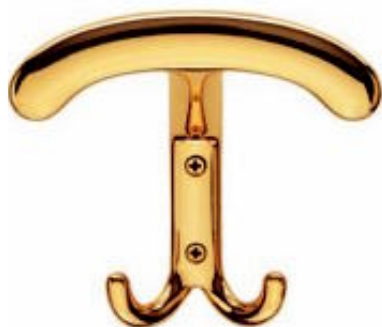

**E 231**  
**Portabito**  
Coathook

**Nikrall Lega Zama UNI 3717** / Nikrall Zamak Alloy UNI 3717

**Oro Zecchino** / Gold Plated  
**Cromsatin** / Satin Chrome  
**Patiné** / Patiné

# E 211

design Valli Workshop

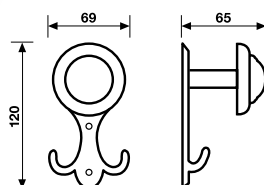

**E 211**  
**Portabito**  
Coathook

**Nikrall Lega Zama UNI 3717** / Nikrall Zamak Alloy UNI 3717

**Oro** / Gold  
**Patiné** / Patiné

# E 183

design Valli Workshop

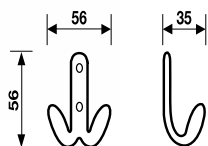

**E 183**  
**Portabito**  
Coathook

**Ottone** / Brass

**Oro Lucido** / Polished Brass

**Cromo** / Chrome

**Cromsatin** / Satin Chrome

**Brunito** / Burnished



# E 182

design Valli Workshop

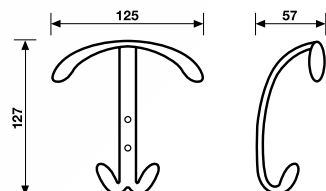

**E 182**  
**Portabito**  
Coathook

**Ottone** / Brass

**Oro Lucido** / Polished Brass

**Cromo** / Chrome

**Cromsatin** / Satin Chrome

**Brunito** / Burnished





# E 180

design Cini Boeri

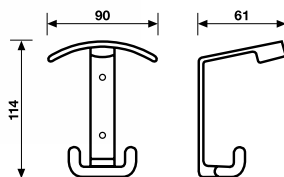

**E 180**  
**Portabito**  
Coathook

**Ottone** / Brass

**Oro Lucido** / Polished Brass  
**Cromsatin** / Satin Chrome

# E 157

design Valli Workshop

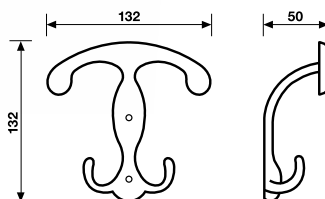

**E 157**  
**Portabito**  
Coathook

**Ottone** / Brass

**Oro** / Brass

# E 137

design Valli Workshop

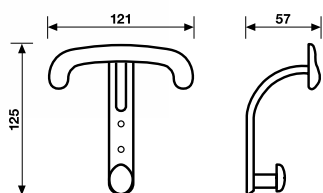

**E 137**  
**Portabito**  
Coathook

**Ottone** / Brass

**Ormatt** / Matt Brass  
**Patiné** / Patiné



# E ELIO

design Valli Workshop

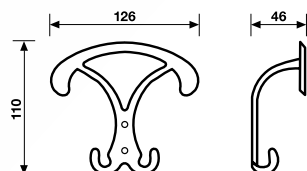

**E ELIO**  
**Portabito**  
Coathook

**Ottone** / Brass

**Oro** / Brass  
**Cromo** / Chrome



# F 621

design Valli Workshop

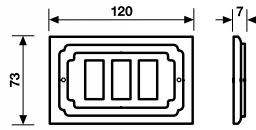
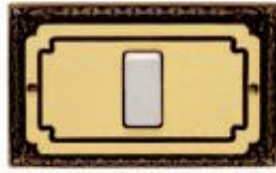

- A 1 Posto / 1 Gang**
- B 2 Posti / 2 Gangs**
- C 3 Posti / 3 Gangs**

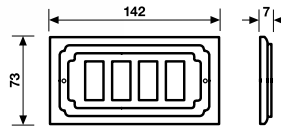

- D 4 Posti / 4 Gangs**

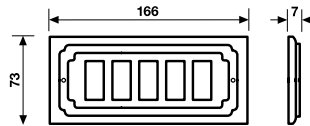

- E 5 Posti / 5 Gangs**

**Ottone / Brass**

**Patiné / Patiné**

Per Serie / For Series

**Magic® bbeino®**

# F 212

design Valli Workshop

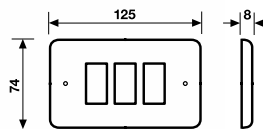

- A 1 Posto / 1 Gang**
- B 2 Posti / 2 Gangs**
- C 3 Posti / 3 Gangs**

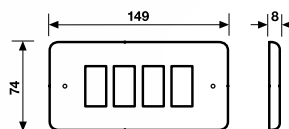

- D 4 Posti / 4 Gangs**

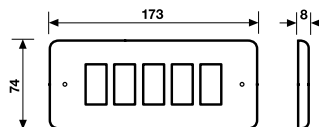

- E 5 Posti / 5 Gangs**

**Nikrall Lega Zama UNI 3717 / Nikrall Zamak Alloy UNI 3717**

**Oro Zecchino / Gold Plated**

Per Serie / For Series

**Magic® bbeino®**

# F 148

design Valli Workshop

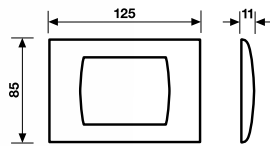

**3 Posti / 3 Gangs**

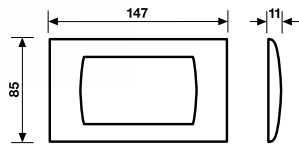

**D 4 Posti / 4 Gangs**

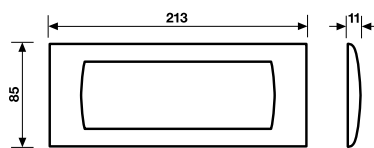

**E 7 Posti / 5 Gangs**

**Ottone / Brass**

**Oro Lucido / Polished Brass**

**Orsatin / Satin Brass**

**Cromsatin / Satin Chrome**

**Anticato / Antique**

Per Serie / For Series

LIVING<sup>®</sup> INTERNATIONAL

**bbeino**



# F 141

design Valli Workshop

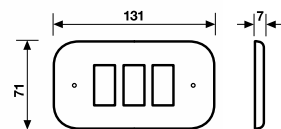

**A 1 Posto / 1 Gang**

**B 2 Posti / 2 Gangs**

**C 3 Posti / 3 Gangs**

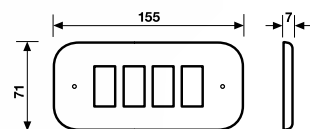

**D 4 Posti / 4 Gangs**

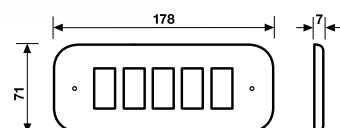

**E 5 Posti / 5 Gangs**

**Ottone / Brass**

**Oro Lucido / Polished Brass**

**Brunito / Burnished**

**Cromsatin / Satin Chrome**

**Anticato / Antique**

Per Serie / For Series

Magic<sup>®</sup> **bbeino**

# F 138

design Valli Workshop

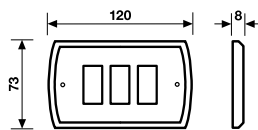

**A 1 Posto / 1 Gang**

**B 2 Posti / 2 Gangs**

**C 3 Posti / 3 Gangs**

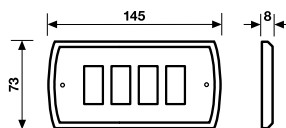

**D 4 Posti / 4 Gangs**

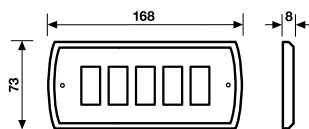

**E 5 Posti / 5 Gangs**

**Ottone / Brass**

**Oro Lucido / Polished Brass**

**Oro / Brass**

Per Serie / For Series

**Magic® bbeino®**



Valli&Valli

# G 614

design Valli Workshop

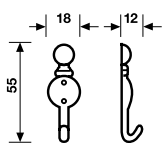

**G 614 (mis. C / size C)**

**Appendiquadri**

Picture Hooks

**Ottone** / Brass

**Oro Lucido** / Polished Brass



# G 613

design Valli Workshop

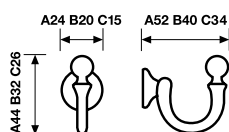

**G 613**

**Gancio per tende**

Curtain Hook

**Ottone** / Brass

**Oro Lucido** / Polished Brass

# G 139

design Valli Workshop

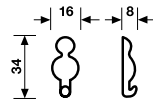

**G 139 (mis. C / size C)**

**Appendiquadri**

Picture Hooks

**Ottone** / Brass

**Oro Lucido** / Polished Brass



Programma Desipro  
Desipro Programme







# Design in Progress



**Esistono molti tipi di handicaps motori, per cui è giusto affermare che ogni disabile dovrebbe avere propri oggetti, progettati appositamente per lui, come propri ausili o protesi personali. In realtà però questa affermazione, per quanto vera, è un'utopia, non sempre praticabile. Le maniglie Desipro della Valli&Valli hanno avviato a questo inconveniente con il procedimento di "design in progress". Il programma Desipro per disabili è infatti una trasformazione progressiva di un'unica maniglia.**

**Avevamo deciso di realizzare il programma Desipro, prevedendo di completarlo per il 1984: cinquantenario di fondazione della nostra società. Una ricorrenza così importante doveva, a nostro parere, essere celebrata con un'iniziativa di carattere sociale, e non specificatamente commerciale. Pertanto abbiamo pensato di offrire un contributo - sia pure modesto - nel settore specifico delle maniglie, avvalendoci anche della nostra lunga esperienza, ponendo allo studio un programma destinato a far superare, nella loro vita quotidiana, le difficoltà prensili degli handicappati, dei disabili e degli anziani. A questo proposito ci siamo messi in contatto con l'Arch. Attilio Marcolli che con molta disponibilità ha subito recepito il messaggio. Con questo "sentire" è nato il programma Desipro. Le ricerche, progettazione e messa a punto dei vari modelli si sono protratte ben oltre il 1984, con oneri decisamente più elevati rispetto al previsto e di quanto normalmente viene stanziato in favore di una delle nostre collezioni più articolate. Abbiamo comunque proseguito nel nostro intento, con l'aiuto dei nostri collaboratori che, con altrettanta dedizione, hanno operato per lo stesso fine. Il programma Desipro era ormai divenuto una sfida per le capacità produttive della nostra società ed un obbligo morale nei confronti di coloro che erano impegnati nella sua realizzazione. La nostra iniziativa rappresenta una conquista del progresso ed una espressione di qualità nella vita.**

There are many kinds of motor handicaps and it is therefore correct to state that each disabled person should have access to his own objects, purposely designed for him, as his own personal aids or prostheses. In reality, this statement, even if true, is a mere utopia that is not always attainable. Valli&Valli with their Desipro handles have got round this problem with the procedure "design in progress".

The Desipro programme for disabled people is in fact a progressive transformation of just one handle.

When we planned the Desipro programme it was with the expectation that it would be completed by 1984: the fiftieth anniversary of our company's establishment. In our opinion, such an important occasion should have been celebrated by an initiative with a social dimension, not merely commercial. Therefore, we thought of making a modest contribution in our specific field of handles, availing ourselves of our long experience in this area, by studying a programme aimed at overcoming the prehensile (grip) difficulties of handicapped, disabled and elderly people in their everyday life; in this connection we contacted Arch. Attilio Marcolli, who immediately greeted the concept with enthusiasm. It was in this atmosphere that the Desipro programme was conceived. However, the research, planning and setting up of the various models extended far beyond 1984, with far greater costs than envisaged and normally allocated in one of our more complex collections. Nevertheless, we continued with our intent, with the assistance of our co-operators who proceeded with the same amount of devotion to this purpose. At that point the Desipro programme became a challenge to the productive capacities of our company, as well as a moral obligation to those involved in its realization. Our initiative represents a victory for progress and a positive expression of quality in life.

# H 156 R8

Programma DESIPRO / design Attilio Marcolli

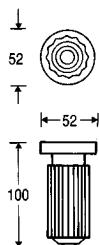

## Maniglia per porta con rosetta senza molla di ritorno

Door handle with rosette without spring

**Metallo ed elastomero siliconico** / Metal and silicone elastomer

**Nero** / Black

**Rosso** / Red

**Blu** / Blue

**Grigio** / Grey

**La maniglia Desipro H 156 R, oltre ad essere utilizzabile a sé stante, è anche l'elemento base di configurazione di tutta la serie, la costante formale che ammette più variabili.**

**La sua forma cilindrica è per favorire una prensilità facile della zona falangea della mano, la "light grip", anche da posizione laterale, dalla carrozzina (e questa è una caratteristica di tutte le maniglie Desipro). L'involucro in elastomero siliconico, a configurazione non anatomica ma geometricamente astratta, idoneo per diverse posizioni e dimensioni della mano, è per impedire lo scivolamento.**

The Desipro handle H 156 R, which can be utilized as an independent article, is also the basic configuration element of the complete series, the constant form allowing many variations. Its cylindrical shape favours an easy prehensile grip by the phalanx area of the hand, a "light grip", also from a side position, from a wheelchair (and this is a characteristic of all Desipro handles). The coating in silicone elastomer is not an anatomic but a geometrically abstract configuration, suitable for various positions and dimensions of hand, which prevents slipping.

**Poniamo in evidenza che le maniglie da porta del Programma Desipro non sono corredate dalle relative bocchette, articoli K 1113 - K 1113Y. Pertanto dovranno essere ordinate a parte.**

We point out that the door handles of the Desipro programme are not provided with the relative escutcheons, article K 1113 - K 1113Y. These should be ordered separately.



# H 156 F

Programma DESIPRO / design Attilio Marcolli

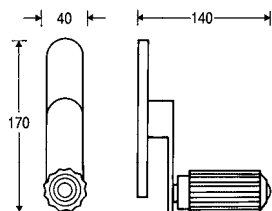

## Maniglia per finestra

Window handle

**Metallo ed elastomero siliconico** / Metal and silicone elastomer

**Nero** / Black

**Rosso** / Red

**Blu** / Blue

**Grigio** / Grey

**La maniglia Desipro H 156 F è una maniglia per l'apertura delle finestre.**

**E' una manovella a cui è applicata la maniglia Desipro H 156 R. La maniglia Desipro H 156 F è configurata per avere gli stessi vantaggi della maniglia Desipro H 156 R, e per evitare nell'azionamento ogni rotazione interna ed esterna della mano attorno al polso, rispetto al braccio.**

The Desipro handle H 156 F is a handle for opening windows. It is a crank to which the Desipro handle H 156 R is applied. The Desipro handle H 156 F is shaped in order to have the same advantages of the Desipro handle H 156 R and to avoid in the action any inside and outside rotation of the hand round the wrist with respect to the arm.

Coordinabile agli articoli H 156 R - H 157 R - H 158 R - H 159 R  
May be co-ordinated with articles



# H 156 R6-7-8 BZG

Programma DESIPRO / design Attilio Marcolli



## Chiusura privacy con apertura d'emergenza

Privacy set with emergency opening

Metallo / Metal

Cromo / Chrome

La chiusura privacy con apertura d'emergenza Desipro H 156 R6-7-8 BZG è una maniglia-chiave da applicare su porte di servizi igienici e locali riservati. Il pezzo è disimmetrico con delineazione di un suo spazio interno a quarto di cerchio, di ridotta profondità quanto basta per favorire l'appoggio parziale del metacarpo sufficiente a far compiere la rotazione; e di un suo spazio esterno ad angolo retto che funge da indicatore visivo dell'azionamento in rotazione.

Infatti la maniglia-chiave è sempre azionabile dall'alto al basso, sia per chiudere che per aprire, ora con rotazione levogira ed ora con rotazione destrogira, molto agevole per forza ridotta della mano. Inoltre lo spazio interno è corrugato per impedire lo slittamento della zona di metacarpo della mano appoggiata. A sua volta la mano normale aziona agevolmente questa maniglia-chiave con tre dita, in modo che ciascun dito sia aderente ad una delle tre facce in profondità della maniglia (due rettilinee ed una curva).

La parte esterna della maniglia-chiave è configurata in modo che la porta non sia apribile dall'esterno, ma tuttavia offra la sicurezza che la porta possa venir aperta dall'esterno in caso di malore o difficoltà di chi si trova all'interno della cabina di servizio.

E' sufficiente in tal caso inserire una moneta nella testata terminale e azionare a cacciavite, e la serratura è smontata.

The privacy closing and emergency opening Desipro H 156 R6-7-8 BZG is a device designed for use on w.c. and bathroom doors. The item is disymmetric with the inside space shaped as a quarter circle, with a reduced depth to aid the partial support of the metacarpus in rotating the handle; the outside is at right angles acting as a visual indicator of the rotation. In fact the handle can always be moved with either anti-clockwise or clockwise direction, very lightly, in order to facilitate a hand with reduced strength. In addition the inside is grooved to prevent the metacarpus area of hand from slipping. In its turn, the normal hand finds it easy to move this handle with three fingers, so that the fingers are in contact with each of the three faces of the handle. The outside of the handle is shaped in such a way that in the event of an emergency such as the occupant feeling unwell or having difficulty the door can be opened from the outside. This is done by inserting a coin into the terminal head to act as a screwdriver and disengaging the lock.

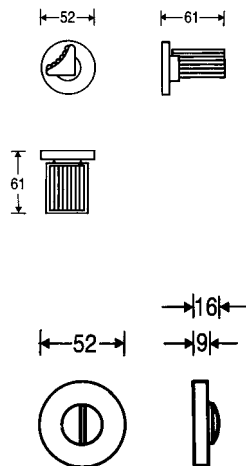

# H 157 R8

Programma DESIPRO / design Attilio Marcolli

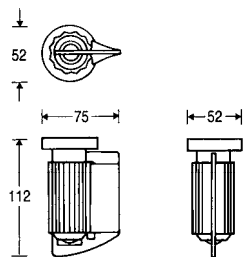

## Maniglia per porta con rosetta con molla di ritorno

Door handle with rosette con spring

**Metallo ed elastomero siliconico** / Metal and silicone elastomer

**Nero** / Black

**Rosso** / Red

**Blu** / Blue

**Grigio** / Grey

**La maniglia Desipro H 157 R è la maniglia Desipro H 156 R con aggiunto l'elemento "opzionale uno", 01.**

**L'elemento 01 è configurato particolarmente per mano distonica, e in generale per mani che si aprono e chiudono abbastanza agevolmente per afferrare un cilindro, ma hanno residui spastici o difficoltà di presa.**

**La maniglia Desipro H 157 R offre un appoggio a dito pollice e zona metacarpo per favorire l'azionamento della mano per aprire una porta.**

The Desipro handle H 157 R is the Desipro handle H 156 R with the addition of the element "optional one", 01.

The element 01 is specifically shaped for a dystonic hand and in general for hands that open and close rather easily to grasp a cylinder, but have spastic residue or grip difficulty.

The Desipro handle H 157 R offers a support for the thumb and the metacarpus area favouring the action of the hand in opening a door.

**Poniamo in evidenza che le maniglie da porta del Programma Desipro non sono corredate dalle relative bocchette, articoli K 1113 - K 1113Y. Pertanto dovranno essere ordinate a parte.**

We point out that the door handles of the Desipro programme are not provided with the relative escutcheons, article K 1113 - K 1113Y. These should be ordered separately.



# H 158 R8

Programma DESIPRO / design Attilio Marcolli

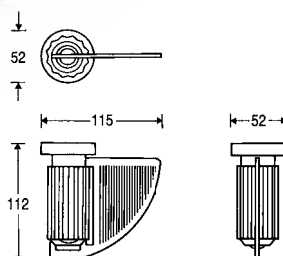

## Maniglia per porta con rosetta con molla di ritorno

Door handle with rosette con spring

**Metallo ed elastomero siliconico** / Metal and silicone elastomer

**Nero** / Black

**Rosso** / Red

**Blu** / Blue

**Grigio** / Grey

**La maniglia Desipro H 158 R è la maniglia Desipro H 156 R con aggiunto l'elemento "opzionale due", 02.**

**L'elemento 02 è configurato particolarmente per mano spastica, e in generale per mani tendenzialmente chiuse a pugno che, pur riuscendo ad aprirsi sino alla potenziale impugnatura a cilindro, hanno ridotta prensilità e sono ipertoniche.**

**La maniglia Desipro H 158 R offre un appoggio globale alla mano: per zona falangea, dito pollice e zona metacarpo.**

**L'azionamento della maniglia può avvenire con il semplice peso della mano con baricentro in zona carpale.**

The Desipro handle H 158 R is the Desipro handle H 156 R with the addition of the element "optional two", 02.

The element 02 is specifically shaped for a spastic hand and in general for hands tending to close in a fist, so that even if they succeed in opening up to the potential cylinder grasp, have a reduced prehensile grip and are hypertonic.

The Desipro handle H 158 R offers a global support to the hand: for phalanx area, thumb and metacarpus area.

The action of the handle can be activated by the mere weight of the hand with barycentre in the carpal area.

**Poniamo in evidenza che le maniglie da porta del Programma Desipro non sono corredate dalle relative bocchette, articoli K 1113 - K 1113Y. Pertanto dovranno essere ordinate a parte.**

We point out that the door handles of the Desipro programme are not provided with the relative escutcheons, article K 1113 - K 1113Y. These should be ordered separately.

# H 159 R8

Programma DESIPRO / design Attilio Marcolli

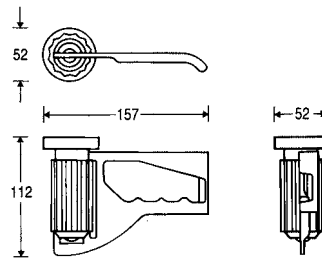

## Maniglia per porta con rosetta con molla di ritorno

Door handle with rosette con spring

**Metallo ed elastomero siliconico** / Metal and silicone elastomer

**Nero** / Black

**Rosso** / Red

**Blu** / Blue

**Grigio** / Grey

**La maniglia Desipro H 159 R è la maniglia Desipro H 156 R con aggiunto l'elemento "opzionale tre", 03.**

**L'elemento 03 è configurato particolarmente per mano atassica, e in generale per mani prive o quasi di coordinamento motorio, ipotoniche, con deformazioni ulnari, e di presa di corta durata se non aiutata o sostenuta.**

**La maniglia Desipro H 159 R offre un appoggio globale della mano, raccordando la zona falangea con le zone metacarpo e carpale, e l'azionamento della maniglia può avvenire per la rotazione data dal peso dell'avambraccio, con baricentro in zona ulnare. Ma può anche avvenire con un colpo di pugno. La configurazione anatomica del vano interno funge da indicatore visivo per l'azionamento della maniglia da parte della mano normale (non quella dell'handicappato).**

The Desipro handle H 159 R is the Desipro handle H 156 R with the addition of the element "optional three", 03.

The element 03 is specifically shaped for an ataxic hand and in general for hands that are without or almost without a motive coordination, hypotonic, with ulnar deformations, or for hands with a grip of short duration if not helped or supported.

The Desipro handle H 159 R offers a global support to the hand by joining together the phalanx area with the metacarpus and carpal one, and the action of the handle can be activated with the rotation given by the weight of the forearm with barycentre in ulnar area. It can also be activated with a punch.

The anatomic configuration of the internal aperture serves as a visual indicator for the working of the handle by a normal hand (not that of the handicapped person).

**Poniamo in evidenza che le maniglie da porta del Programma Desipro non sono corredate dalle relative bocchette, articoli K 1113 - K 1113Y. Pertanto dovranno essere ordinate a parte.**

We point out that the door handles of the Desipro programme are not provided with the relative escutcheons, article K 1113 - K 1113Y. These should be ordered separately.





# K 1113

Programma DESIPRO / design Attilio Marcolli



← 52 → ← 25 →



## Bocchetta foro normale

Standard hole escutcheon

**Metallo** / Metal

**Cromo** / Chrome

**La bocchetta Desipro foro normale K 1113 è una configurazione tronco-conica ad imbuto per agevolare i casi di scoordinamento motorio della mano, si da condurre la chiave ad infilarsi correttamente nella toppa della serratura.**

The Desipro standard escutcheon K 1113 is a cone shaped tunnel configuration to facilitate cases where there is lack of motor co-ordination of the hand, and it enables the key to be guided towards a correct insertion into the keyhole.

# K 1113 Y

Programma DESIPRO / design Attilio Marcolli



← 52 → ← 25 →



## Bocchetta foro cilindro

Euro-profile hole escutcheon

**Metallo** / Metal

**Cromo** / Chrome

**La bocchetta Desipro foro cilindro K 1113 Y è configurata per chiavi per serrature a cilindro che presentano due difficoltà in più rispetto alle chiavi normali: la disimmertia della toppa rispetto alla corona, e la dimensione molto ridotta del foro della toppa. La bocchetta è pertanto un imbuto a tronco di cono disimmetrico, in cui è inciso un canale verticale di guida. L'imbuto conduce in ogni suo punto il terminale della chiave alla guida, e la guida direttamente nella toppa. Le dimensioni dell'imbuto non interferiscono con la rotazione della testa della chiave, con o senza il pezzo Desipro M 189 T.**

The Desipro cylinder escutcheon K 1113 Y is shaped for keys for cylinder locks that present a couple of additional difficulties in comparison with normal keys: the disymmetry of the keyhole towards the rim and the much reduced dimension of the keyhole. Therefore, the escutcheon is a shortened funnel of a disymmetric cone on which a guiding vertical channel is engraved. Each point of the funnel directs the end of the key to the guide and leads it directly to the keyhole. The funnel dimensions do not interfere with the rotation of the key head, with or without the Desipro item M 189 T.

# M 189

Programma DESIPRO / design Attilio Marcolli

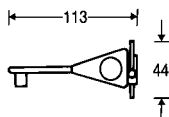

## Chiave per porta

Door key

**Metallo** / Metal

**Cromo** / Chrome

La chiave Desipro M 189 è configurata per essere azionata, oltre che da mano normale, anche da mano tesa con difficoltà di presa minuta (la "presa a chiave" o keypinch). Due anelli aperti in testata, in cui si infilano rispettivamente indice ed anulare mentre il dito medio si posiziona sul profilo allungato della chiave, sono configurati con simmetria rotatoria ciclica, ed ancorati ad un cilindro che permette di affiancarli alla chiave quando non vengono usati. L'ampio foro a disco nella testata oltre ad alleggerire anche visivamente la chiave, permette di appenderla al gancio.

In addition to being used by a normal hand, the key Desipro M 189 is shaped in order that it may be used by a rigid hand with difficulties of minute grip ("the key pinch"). The two open rings at the head, (where the forefinger and the ring finger respectively are inserted, whilst the middle finger is put on the elongated profile of the key) are shaped with a cyclic rotatory symmetry and fixed to a cylinder which enables them to be placed alongside the key when not in use. The wide disc hole at the head, in addition to providing visual relief, allows for hanging the key.



# M 189 T

Programma DESIPRO / design Attilio Marcolli

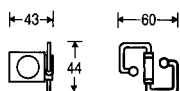

## Testa chiave per porta

Holder door key

**Metallo** / Metal

**Cromo** / Chrome

Il pezzo, simile per azionamento al Desipro M 189 è mobile rispetto alla chiave e tascabile, ed è configurato per chiavi per serrature a cilindro. Sono moltissime le varietà dimensionali delle chiavi per serrature a cilindro (da porte a cassetti ed armadi per ufficio etc.); tuttavia la testa chiave Desipro riesce a soddisfare questa variabilità dimensionale.

This item is similar to Desipro M 189 in its working. The key can be removed and the holder is shaped for use with profile-cylinder lock keys. The dimensional varieties of keys for profile cylinder locks are many (ranging from doors to drawers, cabinets etc.); nevertheless the Desipro key holder can satisfy all of these different requirements.



## Le Caratteristiche Qualitative del Programma Desipro

### Qualitative Characteristics of the Desipro Programme

- 1 Le maniglie Desipro sono il risultato dello studio ergonomico della mano. Sono considerate le variabili antropometriche dal 2,5 al 97,5 percentile delle mani dell'uomo, della donna, e di quelle di età evolutiva dagli 8 ai 14 anni. Sono considerati inoltre i migliori posizionamenti della mano. Questi posizionamenti, coordinati, sono in progressione (dalla maniglia Desipro H 156 R alla maniglia Desipro H 159 R), in modo che le possibili forze in gioco per il funzionamento della mano, compresi muscoli ulnari e radiali, possano collaborare. Le maniglie Desipro, oltre alle prese prevalenti per cui sono state studiate, offrono anche la possibilità di altri tipi di prese.
- 2 Le maniglie Desipro sono applicabili a qualsiasi serramento normale, a telaio in legno. Sono maniglie idonee non solo per ambienti pubblici, cliniche, ospedali, centri di riabilitazione, scuole, ma anche per le case di abitazione. Offrono il vantaggio di non dover modificare le tecnologie di azionamento delle serrature: si applicano agevolmente a qualsiasi porta o finestra in legno già preesistente nell'appartamento.
- 3 Le maniglie Desipro sono configurate in modo da essere agevolmente azionate anche da mani normali.
- 4 Le maniglie Desipro, per il livello di affidabilità e di prestazione che offrono, sono anche relativamente economiche.
- 5 Le maniglie Desipro, pur di particolare configurazione, hanno un ingombro contenuto: la sporgenza massima è di 110 mm (130 mm per le finestre) e la lunghezza massima di 150 mm.
- 6 Le maniglie Desipro sono prodotte in metallo ed elastomero siliconico. Gli elementi opzionali - 01, 02, 03 - configurano maniglie piuttosto aderenti alla porta. Sono caratteristiche di sicurezza ed anti-infiammabilità.
- 7 Le maniglie Desipro sono configurate in modo, per arrotondamenti e smussature, da evitare contusioni o sgraffiature nei movimenti scoordinati della mano. In adiacenza all'attacco al serramento esse hanno un cilindro piatto di mediazione, per un contatto laterale morbido della mano.
- 8 Le maniglie Desipro possono essere corredate anche da chiavi studiate per essere azionate da mani che, pur potendo compiere movimenti di rotazione attorno al polso, non possono contrarsi o compiere prese minute. Anche per le chiavi sono evitate le "heavy grip, pinch grip, key grip". È previsto anche un supporto tascabile da infilare in chiavi per serrature a cilindro. È possibile inoltre applicare alla toppe della serratura un elemento configurato ad imbuto per favorire i movimenti scoordinati di infilaggio della chiave.
- 9 Le maniglie Desipro offrono anche una gradevole visione cromatica. Le parti metalliche sono lucide a specchio, mentre il cilindro di avvolgimento, in elastomero siliconico, della maniglia Desipro H 156 R, che è l'elemento costante che si trova in tutte le maniglie Desipro, è proposto in 4 gamme di colore. Il colore è così predisposto:
  - a. il nero, in quanto colore acromatico, che si lega con grande armonia ai metalli cromati, è indicato per situazioni ambientali di rappresentanza o di sobria eleganza;
  - b. il rosso (rosso cadmio) e il blu (blu cobalto) sono indicati per il loro carattere segnaletico (colori saturi) per ambienti pubblici, come cliniche o scuole, e per ambienti di giovani;
  - c. il grigio è indicato per il suo carattere più spento (colore di ridotta chiarezza) per ambienti più tradizionali, per case di riposo per anziani o per ambienti di degenza.
- 10 Le maniglie Desipro hanno una propria caratteristica estetica. Sono ausili per handicappati, privi però di quelle caratteristiche di ripiego o assistenziali, ortopediche, ospedaliere, che danno al disabile la costante sensazione di essere un anormale o un menomato. Le maniglie Desipro sono oggetti che si propongono come innovazione tipologica, che suscita - per il carattere di novità - una forte attrazione visiva, invogliando sia il disabile sia la persona normale ad usarle per avere un diretto rapporto tattile e cinestesico. Di norma la quantità di informazione estetica e funzionale è tanto maggiore quanto maggiore è l'imprevedibilità del contenuto del messaggio, che dipende dalla sua originalità. La "novità" delle maniglie Desipro presenta, proprio per questo, un alto grado di informazione, e quindi di sollecitazione visiva e tattile. Con questi oggetti il disabile non si sente un menomato rispetto alle persone normali, ma anzi un uomo più avanzato che utilizza forme nuove e innovative. E anche in questo senso il programma Desipro è "design in progress".

- 1 The anthropometric variations are considered from 2.5 to 97.5 percentile grip of the male and female hand and of those with an evolutionary age from 8 to 14 years. Furthermore the best positions of the hand are taken into consideration. These positions, duly co-ordinated, are progressive (from the Desipro handle H 156 R to the Desipro handle H 159 R) so that all possible strengths involved in the hand movement, including ulnar and radial muscles, can cooperate. Desipro handles, besides the specific grips for which they have been studied, offer also the possibility for other kinds of grips.
- 2 Desipro handles can be fitted on any normal wooden door and window frame. These handles are not only suitable for public buildings, clinics, hospitals, rehabilitation centres, schools, but also for residential buildings. They offer the advantage that no modification of locking mechanism is necessary: they easily fit any already installed wooden door or window.
- 3 Desipro handles are shaped in such a way that they can be used by normal hands as well.
- 4 Desipro handles are relatively economic in comparison with the level of reliability and performance they offer.
- 5 Desipro handles, in spite of their special configuration, have a limited dimension: the maximum projection is 110 mm (130 mm for the windows) and the maximum length is 150 mm.
- 6 Desipro handles are produced in metal and silicone elastomer. The optional elements - 01, 02, 03 - configure handles that are adherent to the door. A characteristic of safety and non-inflammability.
- 7 Desipro handles are shaped in such a way that, due to their roundness and smoothness, contusions or scratches by non co-ordinated movements of the hand are avoided. They have a flat intermediary cylinder adjacent to the frame fastening for a smooth side contact by the hand.
- 8 Desipro handles can be completed with keys that are created to be used by hands that, even if they can make rotation movements around the wrist, cannot contract or make minute grips. These keys also avoid "heavy grip, pich grip, key grip". In addition a pocket support to be inserted into the cylinder lock keys has been developed. Furthermore it is possible to apply a funnel-shaped escutcheon to the key hole allowing key insertion even when movements are not coordinated.
- 9 Desipro handles have a pleasant, chromatic look. The metallic parts are bright, whilst the silicone elastomer cylinder of the Desipro handle H 156 R, which is the standard element in all the Desipro handles, is offered in 4 colour ranges. The colour range is as follows:
  - a. black, being it achromatic, match and harmonise with chrome-plated metals: it is suitable for places of entertainment or of sober elegance;
  - b. red (cadmium red) and blue (cobalt blue) are suited for their distinctive features (strong colours) to public buildings, such as clinics or schools, and for places where youth congregate;
  - c. grey is suitable, due to its more sober characteristics (colour of reduced brightness) to more traditional environments, rest-homes for the elderly or institutions for the bed ridden.
- 10 Desipro handles have their own aesthetic feature. They are aids for handicapped people, but without those makeshift welfare, orthopaedic, hospital characteristics that give the disabled person the constant feeling of being a subnormal or a handicapped person. Desipro handles are a typologic innovation that arouses - with their original characteristics - a strong visual attraction that spurs both the disabled and the normal person to use them and get a direct tactile and kinaesthetic relationship. Generally, the amount of aesthetic and functional information depends on the amount of originality and unpredictability included in its message. Desipro handles, being they original "and innovative", therefore offer a high level of information and also visual and tactile stimulus. With these objects the disabled person doesn't feel disabled anymore if compared with other people, but, on the contrary, he or she will feel like a more advanced person using new and innovative forms. It is also in this sense that the Desipro programme is to be considered as "design in progress".



## I Criteri di Configurazione delle Maniglie Desipro

### Development Criteria of Desipro Handles

Le maniglie Desipro sono state configurate con criteri ergonomico-antropometrici, e con criteri determinati dai principali tipi di handicaps della mano.

Sulla base di questi criteri le maniglie Desipro sono applicabili non solo in appartamenti di normali case di abitazione, ma anche in edifici pubblici come scuole, cliniche ed ospedali, ove è prevista la presenza di un certo numero di handicappati ed il tipo di handicap da cui sono affetti.

Ma le maniglie Desipro sono anche configurate con criteri relativi alle tipologie delle porte, applicabili quindi in quegli ambienti pubblici (come le banche per esempio) in cui non sono prevedibili quali tipi di handicappati vi accederanno ed in quale percentuale.

Il criterio per tipologie delle porte è il seguente:

- La maniglia H 156 R (solo impugnatura) da applicare a porte di accesso a saloni ove c'è molto afflusso di persone (salone di una banca, di un municipio, di un'agenzia, etc), ed a porte a doppia cerniera e a ventola.
- La maniglia H 157 R alle porte ad un solo battente degli uffici o degli uffici ricevimento clienti.
- La maniglia H 158 R può sostituire la H 156 R o la H 157 R in particolare (per maggiore visibilità della maniglia e quindi di sicurezza nei movimenti scoordinati) ove le porte siano totalmente in vetro (senza telaio in legno o metallico).
- La maniglia H 159 R è consigliata per le porte di sicurezza, per le porte esterne, per le porte pesanti e per le porte ad ante speciali: a ventaglio, a doppio battente, a battenti apribili a libro, etc.

The Desipro handles have been shaped with ergonomic and anthropometric criteria and with criteria determined by the main kinds of hand disabilities. Based on these criteria, the Desipro handles are not only applicable to apartments and normal residential use, but also to public buildings, such as schools, clinics and hospitals, where the presence of a certain number of disabled persons affected by various types of handicaps can be foreseen.

Moreover the Desipro handles are also developed on the basis of criteria relevant to door types present in public environments (such as banks for instance) where the kinds of disabled persons who will enter and the relative percentage are not foreseeable.

The criterium for these doors types is the following:

- Handle H 156 R (lever only) to be fitted on entrance doors to rooms, where there is a high stream of people (banks, municipal buildings, agencies, etc.) and on doors with double hinge and swinging doors.
- Handle H 157 R on single doors of offices or of customers reception offices.
- Handle H 158 R can replace handle H 156 R or H 157 R (for better visibility of the handle and consequently for more confident non-co-ordinated movements) where doors are completely in glass (without wooden or metallic frame).
- Handle H 159 R is recommended for safety doors, exterior doors, heavy doors and for doors with special leaves: fan-shaped doors, double doors, folding doors, etc.





Collezione V&V Acciaio Inox  
V&V Stainless Steel Collection







## Maniglie per Porta Acciaio Inox Stainless Steel Door Handles



**H 2007** Serie Hekla  
design Antonio Citterio  
**pag. 202**



**H 2003** Serie Pollino  
design Valli Workshop  
**pag. 210**



**H 2006** Serie Teide  
design Valli Workshop  
**pag. 204**



**H 2002** Serie Logan  
design Valli Workshop  
**pag. 212**



**H 2005** Serie Kamet  
design Valli Workshop  
**pag. 206**



**H 2001** Serie Cevedale  
design Valli Workshop  
**pag. 214**



**H 2004** Serie Illimani  
design Valli Workshop  
**pag. 208**



# H 2007

Serie HEKLA / design Antonio Citterio



▲  
**Satinato** / Satin



**Lucido**  
Polished

## Coordinato Matching Elements

**H 2007 F RS**  
Pg. 216



**R 2001**  
**R 2001 Y**  
Pg. 227



**S 2001**  
Pg. 228



**Acciaio Inox AISI 316 L** / Stainless Steel AISI 316 L

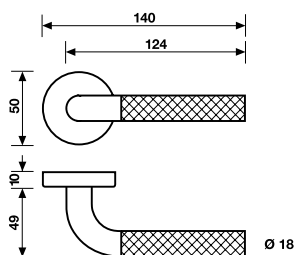

**H 2007 R8**

Maniglie per Porta Acciaio Inox  
Stainless Steel Door Handles

H 2006



204



# H 2006

Serie TEIDE / design Valli Workshop



▲  
**Satinato** / Satin



**Lucido**  
Polished

## Coordinato Matching Elements

**H 2006 F RS**  
Pg. 216



**R 2001**  
**R 2001 Y**  
Pg. 227



**S 2001**  
Pg. 228



**Acciaio Inox AISI 316 L** / Stainless Steel AISI 316 L

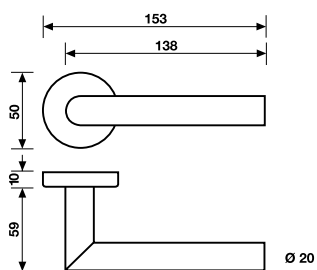

**H 2006 R8**

Maniglie per Porta Acciaio Inox  
Stainless Steel Door Handles

H 2005



206



# H 2005

Serie KAMET / design Valli Workshop



▲  
**Satinato** / Satin



**Lucido**  
Polished

## Coordinato Matching Elements

**H 2005 F RS**  
Pg. 217



**R 2001  
R 2001 Y**  
Pg. 227



**S 2001**  
Pg. 228



**Acciaio Inox AISI 316 L** / Stainless Steel AISI 316 L

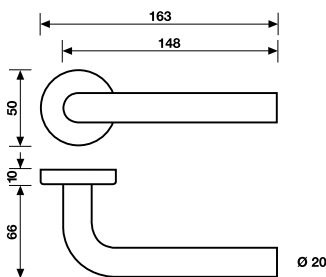

**H 2005 R8**





# H 2004

Serie ILLIMANI / design Valli Workshop



▲  
**Satinato** / Satin



**Lucido**  
Polished

## Coordinato Matching Elements

**H 2004 F RS**  
Pg. 217



**R 2001**  
**R 2001 Y**  
Pg. 227



**S 2001**  
Pg. 228



**Acciaio Inox AISI 316 L** / Stainless Steel AISI 316 L

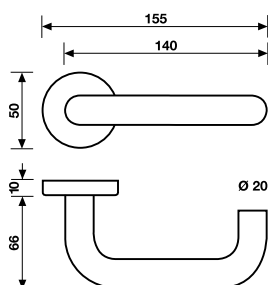

**H 2004 R8**

Maniglie per Porta Acciaio Inox  
Stainless Steel Door Handles

H 2003



# H 2003

Serie POLLINO / design Valli Workshop



▲  
**Satinato** / Satin



**Lucido**  
Polished

## Coordinato Matching Elements

**H 2003 F RS**  
Pg. 218



**R 2001**  
**R 2001 Y**  
Pg. 227



**S 2001**  
Pg. 228



**Acciaio Inox AISI 316 L** / Stainless Steel AISI 316 L

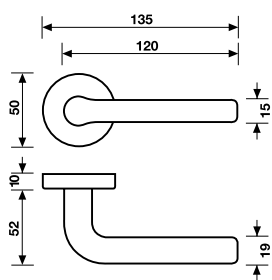

**H 2003 R8**



# H 2002

Serie LOGAN / design Valli Workshop



▲  
**Satinato** / Satin



**Lucido**  
Polished

## Coordinato Matching Elements

**H 2002 F RS**  
Pg. 218



**R 2001**  
**R 2001 Y**  
Pg. 227



**S 2001**  
Pg. 228



**Acciaio Inox AISI 316 L** / Stainless Steel AISI 316 L

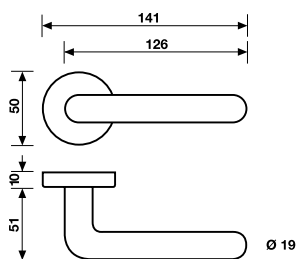

**H 2002 R8**

Maniglie per Porta Acciaio Inox  
Stainless Steel Door Handles

H 2001



214



# H 2001

Serie CEVEDALE / design Valli Workshop



▲  
**Satinato** / Satin



**Lucido**  
Polished

## Coordinato Matching Elements

**H 2001 F RS**  
Pg. 219



**R 2001**  
**R 2001 Y**  
Pg. 227



**S 2001**  
Pg. 228



**Acciaio Inox AISI 316 L** / Stainless Steel AISI 316 L

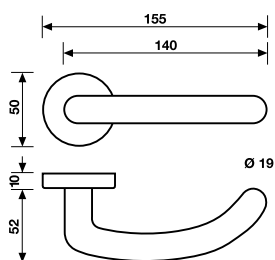

**H 2001 R8**





# H 2007

Serie HEKLA / design Antonio Citterio

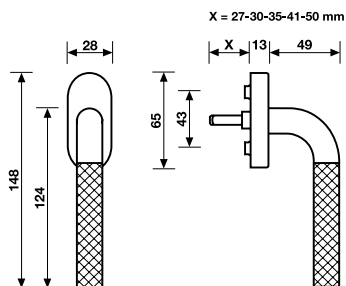

## H 2007 F RS

**Movimento F RS 4 scatti**

Movement 4 click positions

**Acciaio Inox AISI 316 L** / Stainless Steel AISI 316 L

**Satinato** / Satin

**Lucido** / Polished

Maniglia per Porta / Door Handle Pg. 202

# H 2006

Serie TEIDE / design Valli Workshop

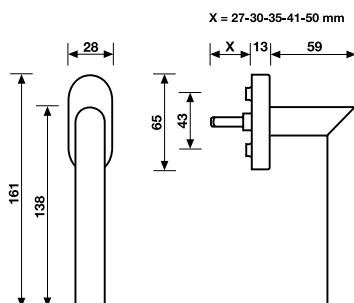

## H 2006 F RS

**Movimento F RS 4 scatti**

Movement 4 click positions

**Acciaio Inox AISI 316 L** / Stainless Steel AISI 316 L

**Satinato** / Satin

**Lucido** / Polished

Maniglia per Porta / Door Handle Pg. 204

# H 2005

Serie KAMET / design Valli Workshop

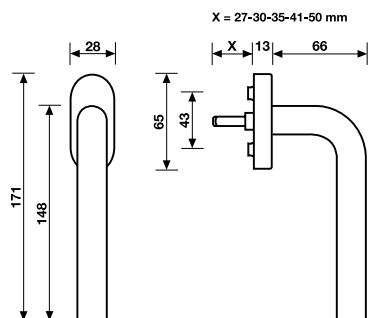

**H 2005 F RS**  
**Movimento F RS 4 scatti**  
Movement 4 click positions

**Acciaio Inox AISI 316 L** / Stainless Steel AISI 316 L

**Satinato** / Satin  
**Lucido** / Polished

Maniglia per Porta / Door Handle Pg. 206



# H 2004

Serie ILLIMANI / design Valli Workshop

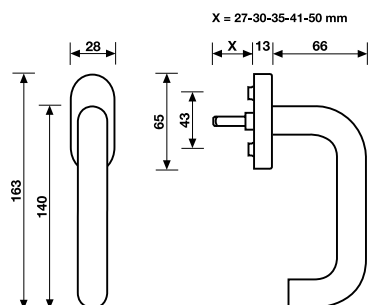

**H 2004 F RS**  
**Movimento F RS 4 scatti**  
Movement 4 click positions

**Acciaio Inox AISI 316 L** / Stainless Steel AISI 316 L

**Satinato** / Satin  
**Lucido** / Polished

Maniglia per Porta / Door Handle Pg. 208



# H 2003

Serie POLLINO / design Valli Workshop

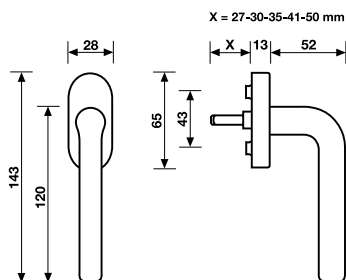

## H 2003 F RS

**Movimento F RS 4 scatti**

Movement 4 click positions

**Acciaio Inox AISI 316 L** / Stainless Steel AISI 316 L

**Satinato** / Satin

**Lucido** / Polished

Maniglia per Porta / Door Handle Pg. 210

# H 2002

Serie LOGAN / design Valli Workshop

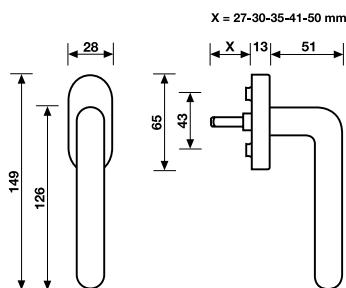

## H 2002 F RS

**Movimento F RS 4 scatti**

Movement 4 click positions

**Acciaio Inox AISI 316 L** / Stainless Steel AISI 316 L

**Satinato** / Satin

**Lucido** / Polished

Maniglia per Porta / Door Handle Pg. 212

# H 2001

Serie CEVEDALE / design Valli Workshop

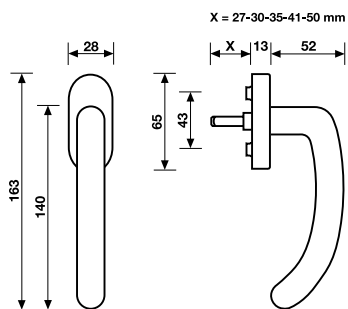

**H 2001 F RS**  
**Movimento F RS 4 scatti**  
Movement 4 click positions

**Acciaio Inox AISI 316 L** / Stainless Steel AISI 316 L

**Satinato** / Satin  
**Lucido** / Polished

Maniglia per Porta / Door Handle Pg. 214





# K 2003

design Valli Workshop

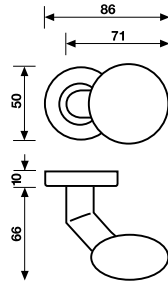

**K 2003 R AS DX, K 2003 R AS SX**

**Pomolo fisso destro e sinistro**

Fixed door knobs right and left

**Acciaio Inox AISI 316 L** / Stainless Steel AISI 316 L

**Satinato** / Satin

**Lucido** / Polished

# K 2002

design Valli Workshop

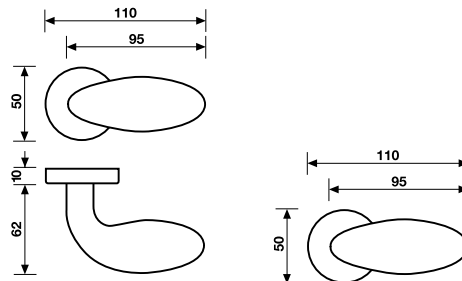

**K 2002 R8, K 2002 R8 Y**

**Acciaio Inox AISI 316 L** / Stainless Steel AISI 316 L

**Satinato** / Satin

**Lucido** / Polished

# K 2001

design Valli Workshop

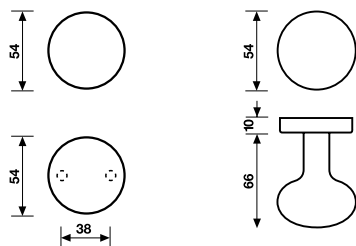

**K 2001 R8, K 2001 R8 Y**

**Acciaio Inox AISI 316 L** / Stainless Steel AISI 316 L

**Satinato** / Satin

**Lucido** / Polished





# P 2005

design Valli Workshop

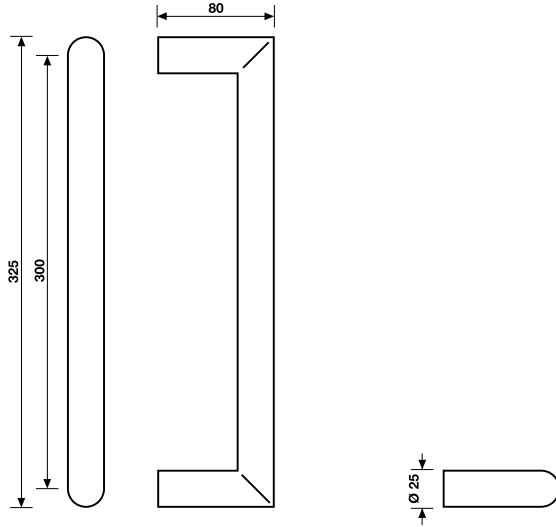

**P 2005 25, P 2005 S 25**  
**Interasse 300mm**  
 Centre Distance

**Acciaio Inox AISI 316 L** / Stainless Steel AISI 316 L

**Satinato** / Satin  
**Lucido** / Polished

Dispositivi di fissaggio da ordinare a parte /  
 Fixings to be ordered separately Pg. 315

# P 2004

design Valli Workshop

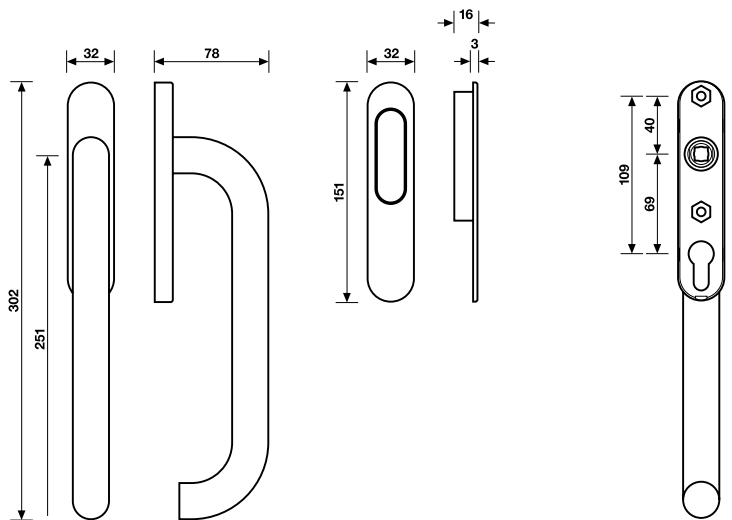

**P 2004**  
**Maniglione alzante scorrevole**  
 Pull handle for sliding patio door

**P 2004Y**  
**Maniglione alzante scorrevole**  
 Pull handle for sliding patio door

**Acciaio Inox AISI 316 L** / Stainless Steel AISI 316 L

**Satinato** / Satin  
**Lucido** / Polished

L'articolo P 2004 Y viene venduto senza la maniglia di trascimento /  
 The article P 2004 Y is sold without the recessed finger pull

# P 2003

design Valli Workshop

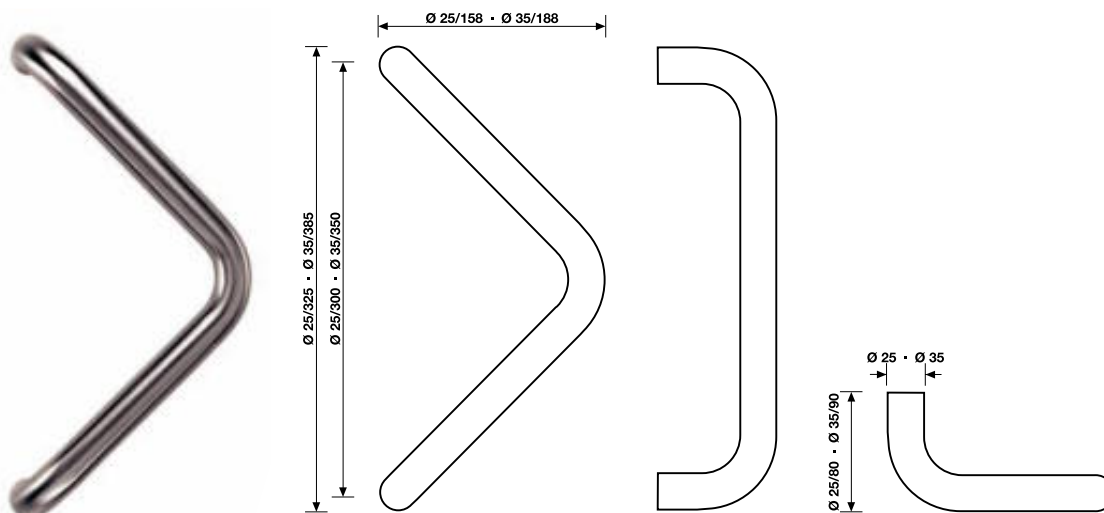

**P 2003 25, P 2003 S 25, P 2003 35, P 2003 S 35**

**Interasse Ø 25 / 300mm, Ø 35 / 350mm**

Centre Distance

**Acciaio Inox AISI 316 L / Stainless Steel AISI 316 L**

**Satinato / Satin**

**Lucido / Polished**

Dispositivi di fissaggio da ordinare a parte /  
Fixings to be ordered separately Pg. 315



# P 2002

design Valli Workshop

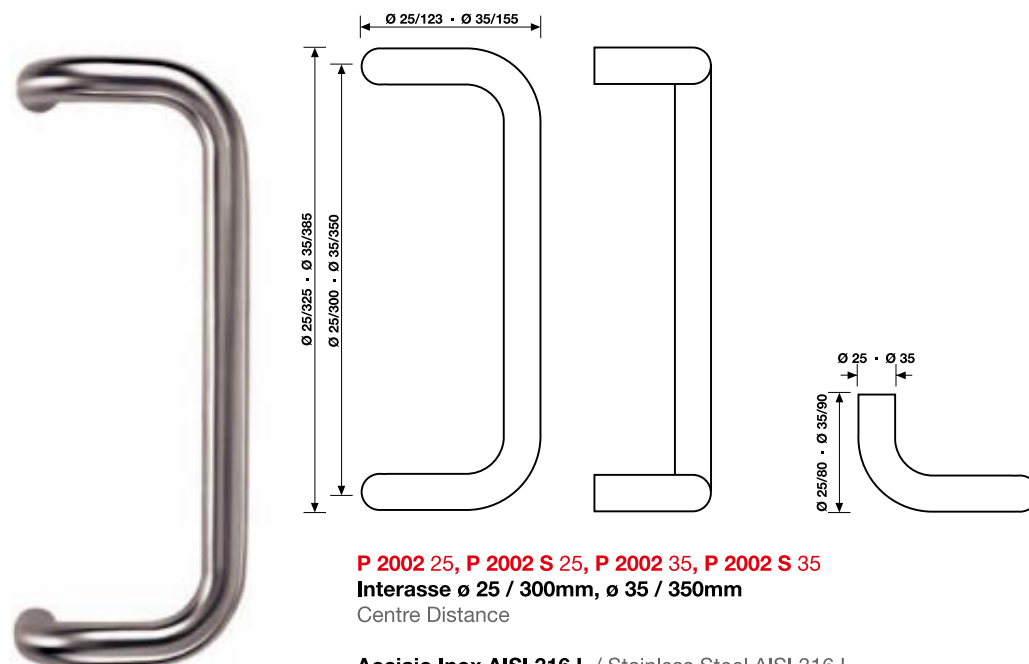

**P 2002 25, P 2002 S 25, P 2002 35, P 2002 S 35**

**Interasse Ø 25 / 300mm, Ø 35 / 350mm**

Centre Distance

**Acciaio Inox AISI 316 L / Stainless Steel AISI 316 L**

**Satinato / Satin**

**Lucido / Polished**

Dispositivi di fissaggio da ordinare a parte /  
Fixings to be ordered separately Pg. 315





# P 2001

design Valli Workshop

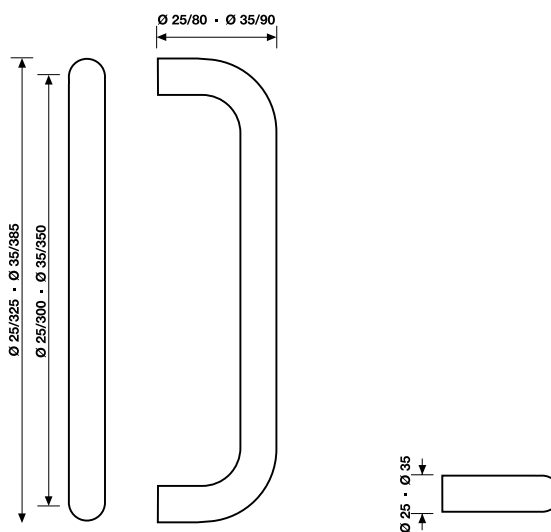

**P 2001 25, P 2001 S 25, P 2001 35, P 2001 S 35**

**Interasse Ø 25 / 300mm, Ø 35 / 350mm**

Centre Distance

**Acciaio Inox AISI 316 L / Stainless Steel AISI 316 L**

**Satinato / Satin**

**Lucido / Polished**

Dispositivi di fissaggio da ordinare a parte /  
Fixings to be ordered separately Pg. 315

# K 1224

design Valli Workshop

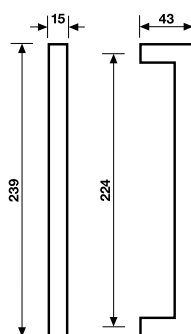

**K 1224**

**Interasse 224mm**

Centre Distance

**Acciaio Inox AISI 304 / Stainless Steel AISI 304**

**Satinato / Satin**

Completo di dispositivi di fissaggio per montaggio singolo e in coppia su legno, in coppia su vetro / Complete with fixing systems for mounting singly and in pairs on wood, in pairs on glass

# K 1219

design Valli Workshop

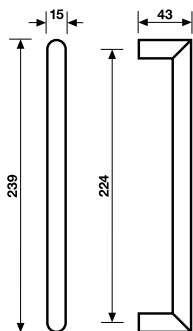

**K 1219**  
**Interasse 224mm**  
Centre Distance

**Acciaio Inox AISI 304** / Stainless Steel AISI 304

**Satinato** / Satin

Completo di dispositivi di fissaggio per montaggio singolo e in coppia su legno, in coppia su vetro / Complete with fixing systems for mounting singly and in pairs on wood, in pairs on glass



# L 2001

design Valli Workshop

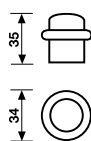

**L 2001**  
**Fermaporta**  
Door stop

**Acciaio Inox AISI 316 L** / Stainless Steel AISI 316 L

**Satinato** / Satin  
**Lucido** / Polished



# R 2001

design Valli Workshop

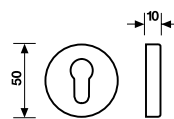
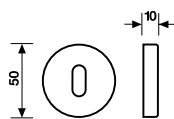

**R 2001 RN**  
**Bocchetta foro normale**  
Standard hole escutcheon

**R 2001 RY**  
**Bocchetta foro cilindro**  
Euro-profile hole escutcheon

**Acciaio Inox AISI 316 L** / Stainless Steel AISI 316 L

**Satinato** / Satin  
**Lucido** / Polished



# R 2001 OV

design Valli Workshop

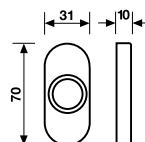
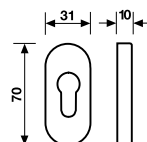

**R 2001 RY OV**  
**Bocchetta foro cilindro**  
Euro-profile hole escutcheon

**R 2001 RS OV**  
**Rosetta**  
Rosette

**Acciaio Inox AISI 316 L** / Stainless Steel AISI 316 L

**Satinato** / Satin  
**Lucido** / Polished



# S 2001 R

design Valli Workshop

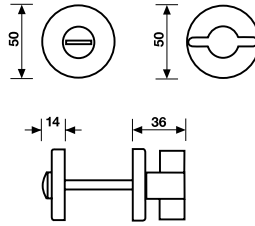

**S 2001 R6-7-8 BZG**  
**Chiusure privacy BZG**  
Bathroom privacy sets

**Acciaio Inox AISI 316 L** / Stainless Steel AISI 316 L

**Satinato** / Satin  
**Lucido** / Polished

# S 2001 RS

design Valli Workshop

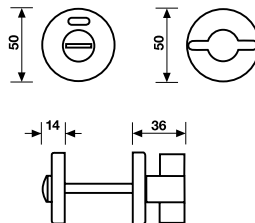

**S 2001 RS6-7-8 BZG**  
**Chiusure privacy BZG**  
Bathroom privacy sets

**Acciaio Inox AISI 316 L** / Stainless Steel AISI 316 L

**Satinato** / Satin  
**Lucido** / Polished





Collezione V&V Accessori del Mobile  
V&V Cabinet Hardware Collection







# A 2053

design Valli Workshop

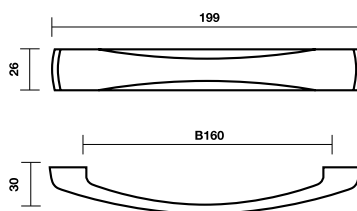

**Nikrall Lega Zama UNI 3717** / Nikrall Zamak Alloy UNI 3717

**B** ♦♦ mm 160 [6.5/16"]

**Cromo** / Chrome

**Nikmatt** / Satin Nickel

# A 2052

design Valli Workshop

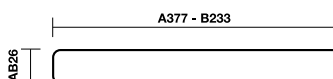

**Alluminio** / Alluminium

**A** ♦♦ mm 320 [12.5/8"]

**Nikmatt** / Satin Nickel

**B** ♦♦ mm 192/160 [7.9/16"]

**Nikmatt** / Satin Nickel

# A 2050

design Carlesi Design

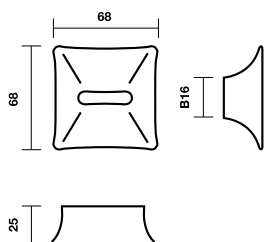

**Nikrall Lega Zama UNI 3717** / Nikrall Zamak Alloy UNI 3717

**B**  $\diamond$   $\diamond$  mm 16 [5/8"]

**Cromo** / Chrome

**Nikmatt** / Satin Nickel



# A 2048

design Carlesi Design

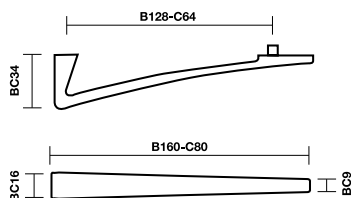

**Nikrall Lega Zama UNI 3717** / Nikrall Zamak Alloy UNI 3717

**B**  $\diamond$   $\diamond$  mm 128 [5"]

**Cromo** / Chrome

**Nikmatt** / Satin Nickel

**C**  $\diamond$   $\diamond$  mm 64 [1.1/2"]

**Cromo** / Chrome

**Nikmatt** / Satin Nickel

# A 2047

design Giancarlo Vegni

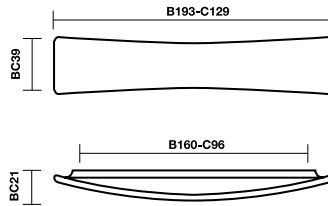

**Nikrall Lega Zama UNI 3717** / Nikrall Zamak Alloy UNI 3717

**B**  $\diamond$   $\diamond$  mm 160 [6.5/16"]

**Cromo** / Chrome

**Nikmatt** / Satin Nickel

**C**  $\diamond$   $\diamond$  mm 96 [3.3/4"]

**Cromo** / Chrome

**Nikmatt** / Satin Nickel

# A 2046

design Carlesi Design

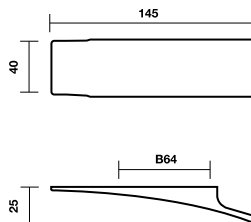

**Nikrall Lega Zama UNI 3717** / Nikrall Zamak Alloy UNI 3717

**B**  $\diamond$   $\diamond$  mm 64 [1.1/2"]

**Cromo** / Chrome

**Nikmatt** / Satin Nickel



# A 2045

design Zengiaro Associati

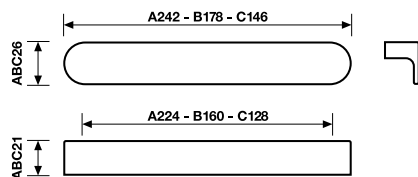

**Nikrall Lega Zama UNI 3717** / Nikrall Zamak Alloy UNI 3717

**A** ♦♦ mm **224** [8.13/16"]

**Nikmatt** / Satin Nickel

**B** ♦♦ mm **160** [6.5/16"]

**Nikmatt** / Satin Nickel

**C** ♦♦ mm **128** [5"]

**Nikmatt** / Satin Nickel

# A 2044

design Zengiaro Associati

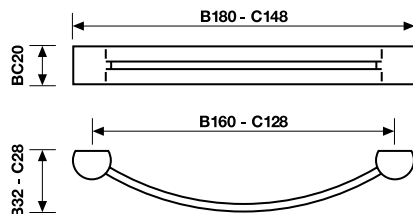

**Nikrall Lega Zama UNI 3717** / Nikrall Zamak Alloy UNI 3717

**B** ♦♦ mm **160** [6.5/16"]

**Cromo** / Chrome

**Cromsatin** / Satin Chrome

**C** ♦♦ mm **128** [5"]

**Cromo** / Chrome

**Cromsatin** / Satin Chrome



# A 2043

design Giancarlo Vegni

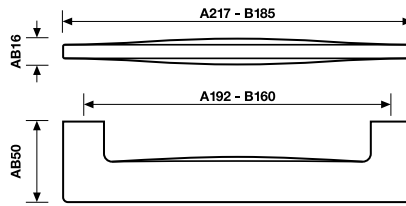

**Nikrall Lega Zama UNI 3717** / Nikrall Zamak Alloy UNI 3717

**A**  $\diamond\diamond$  mm 192 [7.9/16"]

**Nikmatt** / Satin Nickel

**B**  $\diamond\diamond$  mm 160 [6.5/16"]

**Nikmatt** / Satin Nickel

# A 2042

design Frank O. Gehry

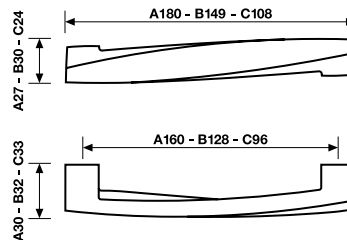

**Nikrall Lega Zama UNI 3717** / Nikrall Zamak Alloy UNI 3717

**A**  $\diamond\diamond$  mm 160 [6.5/16"]

**Cromo** / Chrome

**Cromsatin** / Satin Chrome

**B**  $\diamond\diamond$  mm 128 [5"]

**Cromo** / Chrome

**Cromsatin** / Satin Chrome

**C**  $\diamond\diamond$  mm 96 [3.3/4"]

**Cromo** / Chrome

**Cromsatin** / Satin Chrome



# A 2041

design Giancarlo Vegni

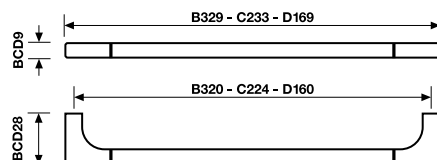

**Nikrall Lega Zama UNI 3717 e Ottone** / Nikrall Zamak Alloy  
UNI 3717 and Brass

**B**  $\diamond\diamond$  mm 320 [12.5/8"]  
**Cromo-Cromsatin** / Chrome-Satin Chrome  
**Nikmatt** / Satin Nickel

**C**  $\diamond\diamond$  mm 224 [8.13/16"]  
**Cromo-Cromsatin** / Chrome-Satin Chrome  
**Nikmatt** / Satin Nickel

**D**  $\diamond\diamond$  mm 160 [6.5/16"]  
**Cromo-Cromsatin** / Chrome-Satin Chrome  
**Nikmatt** / Satin Nickel



# A 2040

design Giancarlo Vegni

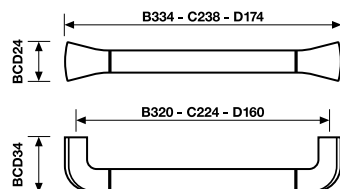

**Nikrall Lega Zama UNI 3717 e Ottone** / Nikrall Zamak Alloy  
UNI 3717 and Brass

**B**  $\diamond\diamond$  mm 320 [12.5/8"]  
**Cromo-Cromsatin** / Chrome-Satin Chrome  
**Cromsatin** / Satin Chrome

**C**  $\diamond\diamond$  mm 224 [8.13/16"]  
**Cromo-Cromsatin** / Chrome-Satin Chrome  
**Cromsatin** / Satin Chrome

**D**  $\diamond\diamond$  mm 160 [6.5/16"]  
**Cromo-Cromsatin** / Chrome-Satin Chrome  
**Cromsatin** / Satin Chrome

# A 2039

design Valli Workshop

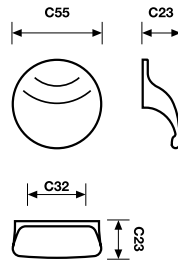

**Nikrall Lega Zama UNI 3717** / Nikrall Zamak Alloy UNI 3717

**C**  $\diamond\diamond$  mm 32 [1.1/4"]

**Cromo** / Chrome

**Nikmatt** / Satin Nickel

# A 2036

design Studio Sara Mano

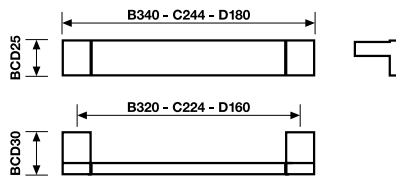

**Nikrall Lega Zama UNI 3717 e Ottone** / Nikrall Zamak Alloy UNI 3717 and Brass

**B**  $\diamond\diamond$  mm 320 [12.5/8"]

**Cromsatin** / Satin Chrome

**Cromo-Cromsatin** / Chrome-Satin Chrome

**C**  $\diamond\diamond$  mm 224 [8.13/16"]

**Cromsatin** / Satin Chrome

**Cromo-Cromsatin** / Chrome-Satin Chrome

**D**  $\diamond\diamond$  mm 160 [6.5/16"]

**Cromsatin** / Satin Chrome

**Cromo-Cromsatin** / Chrome-Satin Chrome

# A 2035

design Leon Krier

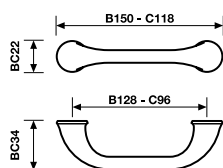

**Nikrall Lega Zama UNI 3717** / Nikrall Zamak Alloy UNI 3717

**B** ♦♦ mm 128 [5"]

**Orantop** / Antique Matt Gold

**Arant** / Antique Silver

**C** ♦♦ mm 96 [3,3/4"]

**Orantop** / Antique Matt Gold

**Arant** / Antique Silver



# A 2034

design Leon Krier

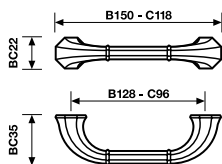

**Nikrall Lega Zama UNI 3717** / Nikrall Zamak Alloy UNI 3717

**B** ♦♦ mm 128 [5"]

**Orantop** / Antique Matt Gold

**Arant** / Antique Silver

**C** ♦♦ mm 96 [3,3/4"]

**Orantop** / Antique Matt Gold

**Arant** / Antique Silver



# A 2032

design Studio Carlesi Design

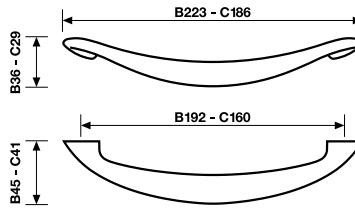

**Nikrall Lega Zama UNI 3717** / Nikrall Zamak Alloy UNI 3717

**B**  $\diamond\diamond$  mm 192 [7.9/16"]  
**Cromsatin** / Satin Chrome  
**Cromo** / Chrome  
**Arant** / Antique Silver

**C**  $\diamond\diamond$  mm 160 [6.5/16"]  
**Cromsatin** / Satin Chrome  
**Cromo** / Chrome  
**Arant** / Antique Silver

# A 2031

design Studio Carlesi Design

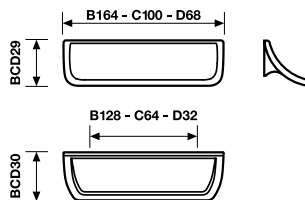

**Nikrall Lega Zama UNI 3717** / Nikrall Zamak Alloy UNI 3717

**B**  $\diamond\diamond$  mm 128 [5"]  
**Nikmatt** / Satin Nickel  
**Cromo** / Chrome

**C**  $\diamond\diamond$  mm 64 [2.1/2"]  
**Nikmatt** / Satin Nickel  
**Cromo** / Chrome

**D**  $\diamond\diamond$  mm 32 [1.1/4"]  
**Nikmatt** / Satin Nickel  
**Cromo** / Chrome



# A 2029

design Giancarlo Vegni

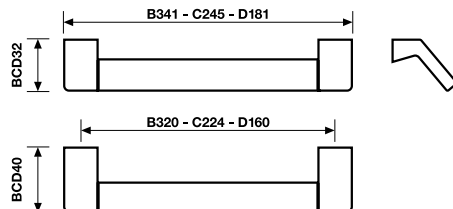

**Nikrall Lega Zama UNI 3717 e Ottone** / Nikrall Zamak Alloy UNI 3717 and Brass

**B**  $\diamond\diamond$  mm 320 [12.5/8"]

**Cromsatin** / Satin Chrome

**Cromo-Cromsatin** / Chrome-Satin Chrome

**C**  $\diamond\diamond$  mm 224 [8.13/16"]

**Cromsatin** / Satin Chrome

**Cromo-Cromsatin** / Chrome-Satin Chrome

**D**  $\diamond\diamond$  mm 160 [6.5/16"]

**Cromsatin** / Satin Chrome

**Cromo-Cromsatin** / Chrome-Satin Chrome



# A 2027

design Giancarlo Vegni

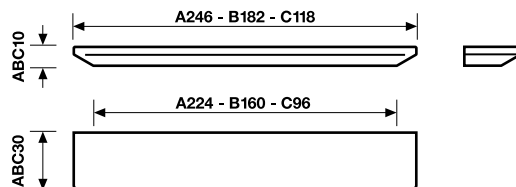

**Nikrall Lega Zama UNI 3717** / Nikrall Zamak Alloy UNI 3717

**A**  $\diamond\diamond$  mm 224 [8.13/16"]

**Nikmatt** / Satin Nickel

**Cromo** / Chrome

**B**  $\diamond\diamond$  mm 160 [6.5/16"]

**Nikmatt** / Satin Nickel

**Cromo** / Chrome

**C**  $\diamond\diamond$  mm 96 [3.3/4"]

**Nikmatt** / Satin Nickel

**Cromo** / Chrome

# A 2026

design Marianelli e Sordina

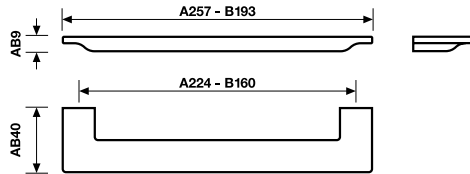

**Nikrall Lega Zama UNI 3717** / Nikrall Zamak Alloy UNI 3717

**A**  $\diamond\diamond$  mm 224 [8.13/16"]

**Nikmatt** / Satin Nickel

**Cromo** / Chrome

**B**  $\diamond\diamond$  mm 160 [6.5/16"]

**Nikmatt** / Satin Nickel

**Cromo** / Chrome

# A 2025

design Antonio Citterio

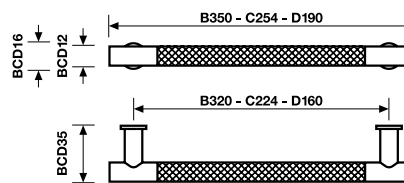

**Acciaio Inox** / Stainless Steel

**B**  $\diamond\diamond$  mm 320 [12.5/8"]

**Satinato** / Satin

**C**  $\diamond\diamond$  mm 224 [8.13/16"]

**Satinato** / Satin

**D**  $\diamond\diamond$  mm 160 [6.5/16"]

**Satinato** / Satin

# A 2024

design Studio Carlesi Design

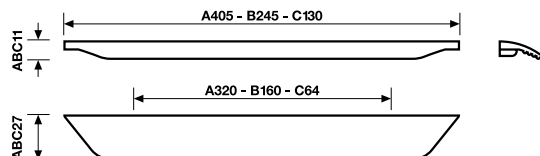

**Nikrall Lega Zama UNI 3717 / Nikrall Zamak Alloy UNI 3717**

**A**  $\diamond\diamond$  mm 320 [12.5/8"]

**Nikmatt** / Satin Nickel

**Cromo** / Chrome

**B**  $\diamond\diamond$  mm 160 [6.5/16"]

**Nikmatt** / Satin Nickel

**Cromo** / Chrome

**C**  $\diamond\diamond$  mm 64 [1.1/2"]

**Nikmatt** / Satin Nickel

**Cromo** / Chrome

# A 2023

design Giancarlo Vegni

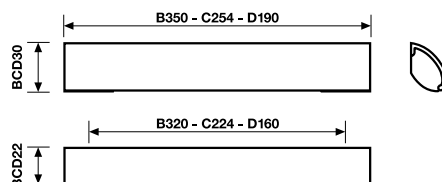

**Nikrall Lega Zama UNI 3717 e Ottone / Nikrall Zamak Alloy UNI 3717 and Brass**

**B**  $\diamond\diamond$  mm 320 [12.5/8"]

**Cromsatin** / Satin Chrome

**Nikmatt** / Satin Nickel

**C**  $\diamond\diamond$  mm 224 [8.13/16"]

**Cromsatin** / Satin Chrome

**Nikmatt** / Satin Nickel

**D**  $\diamond\diamond$  mm 160 [6.5/16"]

**Cromsatin** / Satin Chrome

**Nikmatt** / Satin Nickel

# A 2022

design Mario Mazzer

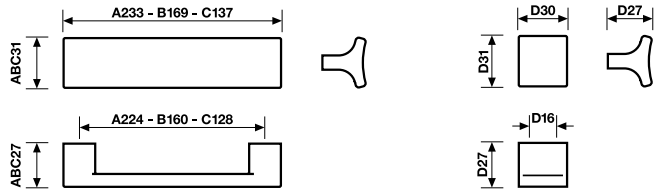

Nikrall Lega Zama UNI 3717 / Nikrall Zamak Alloy UNI 3717

**A**  $\diamond\diamond$  mm 224 [8.13/16"]

**Cromo** / Chrome

**Cromsatin** / Satin Chrome

**B**  $\diamond\diamond$  mm 160 [6.5/16"]

**Cromo** / Chrome

**Cromsatin** / Satin Chrome

**C**  $\diamond\diamond$  mm 128 [5"]

**Cromo** / Chrome

**Cromsatin** / Satin Chrome

**D**  $\diamond\diamond$  mm 16 [5/8"]

**Cromo** / Chrome

**Cromsatin** / Satin Chrome

# A 2021

design Mario Mazzer

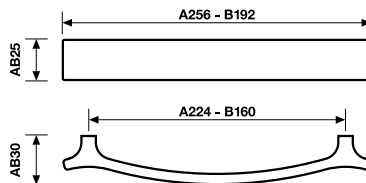

Nikrall Lega Zama UNI 3717 / Nikrall Zamak Alloy UNI 3717

**A**  $\diamond\diamond$  mm 224 [8.13/16"]

**Cromo** / Chrome

**Nikmatt** / Satin Nickel

**B**  $\diamond\diamond$  mm 160 [6.5/16"]

**Cromo** / Chrome

**Nikmatt** / Satin Nickel



# A 2020

design Giancarlo Vegni

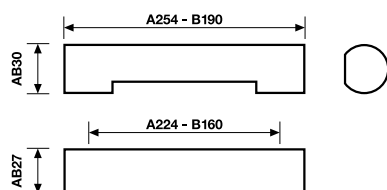

**Nikrall Lega Zama UNI 3717 / Nikrall Zamak Alloy UNI 3717**

**A**  $\diamond\diamond$  mm 224 [8.13/16"]

**Cromo / Chrome**

**Cromsatin / Satin Chrome**

**B**  $\diamond\diamond$  mm 160 [6.5/16"]

**Cromo / Chrome**

**Cromsatin / Satin Chrome**

# A 2019

design Giancarlo Vegni

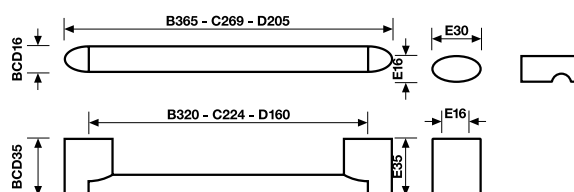

**Nikrall Lega Zama UNI 3717 e Ottone / Nikrall Zamak Alloy UNI 3717 and Brass**

**B**  $\diamond\diamond$  mm 320 [12.5/8"]

**Cromo-Cromsatin / Chrome-Satin Chrome**

**Cromsatin / Satin Chrome**

**C**  $\diamond\diamond$  mm 224 [8.13/16"]

**Cromo-Cromsatin / Chrome-Satin Chrome**

**Cromsatin / Satin Chrome**

**D**  $\diamond\diamond$  mm 160 [6.5/16"]

**Cromo / Chrome**

**Cromsatin / Satin Chrome**

**E**  $\diamond\diamond$  mm 16 [5/8"]

**Cromsatin / Satin Chrome**

# A 2017

design Leon Krier

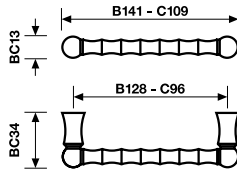

**Nikrall Lega Zama UNI 3717** / Nikrall Zamak Alloy UNI 3717

**B**  $\diamond\diamond$  mm 128 [5"]

**Arant** / Antique Silver

**Orantop** / Antique Matt Gold

**Orolux** / Brass Plated

**C**  $\diamond\diamond$  mm 96 [3.3/4"]

**Arant** / Antique Silver

**Orantop** / Antique Matt Gold

**Orolux** / Brass Plated

# A 2016

design Studio Carlesi Design

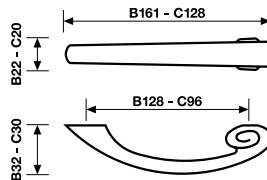

**Nikrall Lega Zama UNI 3717** / Nikrall Zamak Alloy UNI 3717

**B**  $\diamond\diamond$  mm 128 [5"]

**Arant** / Antique Silver

**Orantop** / Antique Matt Gold

**C**  $\diamond\diamond$  mm 96 [3.3/4"]

**Arant** / Antique Silver

**Orantop** / Antique Matt Gold

# A 2015

design Ergo Design

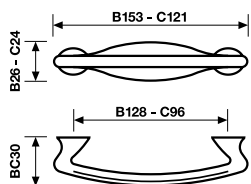

**Nikrall Lega Zama UNI 3717 / Nikrall Zamak Alloy UNI 3717**

**B**  $\diamond\diamond$  mm 128 [5"]

**Arant** / Antique Silver

**Orantop** / Antique Matt Gold

**Orolux** / Brass Plated

**C**  $\diamond\diamond$  mm 96 [3.3/4"]

**Arant** / Antique Silver

**Orantop** / Antique Matt Gold

**Orolux** / Brass Plated



# A 2010

design Valli Workshop

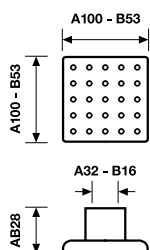

**Nikrall Lega Zama UNI 3717 / Nikrall Zamak Alloy UNI 3717**

**A**  $\diamond\diamond$  mm 32 [1.1/4"]

**Cromo** / Chrome

**B**  $\diamond\diamond$  mm 16 [5/8"]

**Cromo** / Chrome



# A 2009

design Studio Carlesi Design

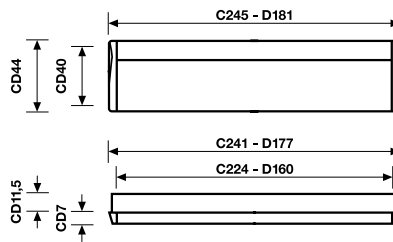

**Nikrall Lega Zama UNI 3717 e Alluminio** / Nikrall Zamak Alloy UNI 3717 and Aluminium

**C**  $\diamond\diamond$  mm 224 [8.13/16"]

**Alu 7011**

**D**  $\diamond\diamond$  mm 160 [6.5/16"]

**Alu 7011**

# A 2008

design Studio Carlesi Design

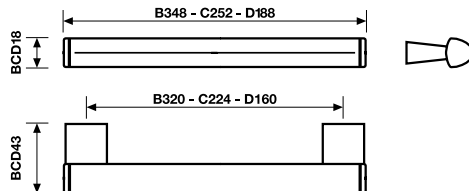

**Nikrall Lega Zama UNI 3717 e Ottone** / Nikrall Zamak Alloy UNI 3717 and Brass

**B**  $\diamond\diamond$  mm 320 [12.5/8"]

**Cromo-Cromsatin** / Chrome-Satin Chrome  
**Cromsatin** / Satin Chrome

**C**  $\diamond\diamond$  mm 224 [8.13/16"]

**Cromo-Cromsatin** / Chrome-Satin Chrome  
**Cromsatin** / Satin Chrome

**D**  $\diamond\diamond$  mm 160 [6.5/16"]

**Cromo-Cromsatin** / Chrome-Satin Chrome  
**Cromsatin** / Satin Chrome

# A 2006

design Zengiaro Associati

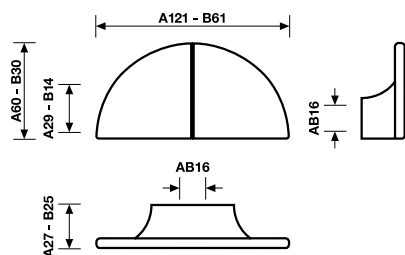

**Nikrall Lega Zama UNI 3717 / Nikrall Zamak Alloy UNI 3717**

**A mm 121/  $\diamond\diamond$  16 [5/8"]**

**Cromo / Chrome**

**Cromsatin/ Satin Chrome**

**B mm 61/  $\diamond\diamond$  16 [5/8"]**

**Cromo / Chrome**

**Cromsatin/ Satin Chrome**

# A 2005

design Zengiaro Associati

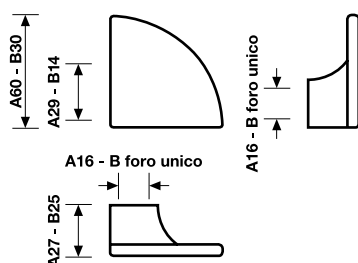

**Nikrall Lega Zama UNI 3717 / Nikrall Zamak Alloy UNI 3717**

**A  $\diamond\diamond$  mm 16 [5/8"]**

**Cromo / Chrome**

**Cromsatin/ Satin Chrome**

**B (foro unico / one hole only)**

**Cromo / Chrome**

**Cromsatin/ Satin Chrome**



# A 2003

design Giancarlo Vegni

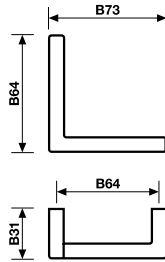

**Nikrall Lega Zama UNI 3717** / Nikrall Zamak Alloy UNI 3717

**B**  $\diamond\diamond$  mm 64 [2.1/2"]

**Cromo** / Chrome

**Cromsatin** / Satin Chrome

# A 320

design Antonio Citterio

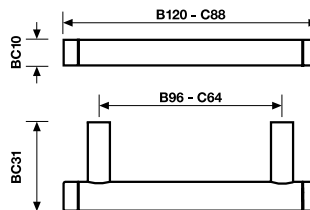

**Ottone** / Brass

**B**  $\diamond\diamond$  mm 96 [3.3/4"]

**Cromo-Nikmatt** / Chrome-Nikmatt

**C**  $\diamond\diamond$  mm 64 [2.1/2"]

**Cromo-Nikmatt** / Chrome-Nikmatt



# A 296

design Giancarlo Vegni

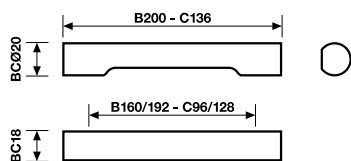

**Nikrall Lega Zama UNI 3717** / Nikrall Zamak Alloy UNI 3717

**B**  $\diamond\diamond$  mm 160/192 [6.5/16"/7.9/16"]

**Cromo** / Chrome

**Cromsatin** / Satin Chrome

**C**  $\diamond\diamond$  mm 96/128 [3.3/4"/5"]

**Cromo** / Chrome

**Cromsatin** / Satin Chrome

# A 295

design Giancarlo Vegni

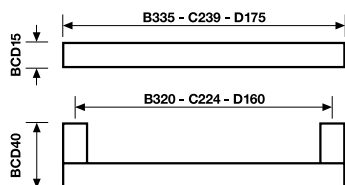

**Nikrall Lega Zama UNI 3717 e Ottone**

Nikrall Zamak Alloy UNI 3717 and Brass

**B**  $\diamond\diamond$  mm 320 [12.5/8"]

**Cromo** / Chrome

**Cromsatin** / Satin Chrome

**C**  $\diamond\diamond$  mm 224 [8.13/16"]

**Cromo** / Chrome

**Cromsatin** / Satin Chrome

**D**  $\diamond\diamond$  mm 160 [6.5/16"]

**Cromo** / Chrome

**Cromsatin** / Satin Chrome

# A 291

design Itamar Harari

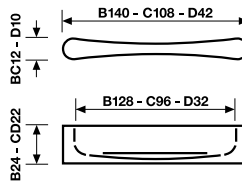

**Nikrall Lega Zama UNI 3717** / Nikrall Zamak Alloy UNI 3717

- B**  $\diamond\diamond$  mm 128 [5"]  
**Nikmatt** / Satin Nickel
- C**  $\diamond\diamond$  mm 96 [3.3/4"]  
**Nikmatt** / Satin Nickel
- D**  $\diamond\diamond$  mm 32 [1.1/4"]  
**Nikmatt** / Satin Nickel

# A 290

design Itamar Harari

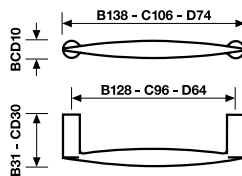

**Nikrall Lega Zama UNI 3717** / Nikrall Zamak Alloy UNI 3717

- B**  $\diamond\diamond$  mm 128 [5"]  
**Cromo** / Chrome  
**Nikmatt** / Satin Nickel
- C**  $\diamond\diamond$  mm 96 [3.3/4"]  
**Cromo** / Chrome  
**Nikmatt** / Satin Nickel
- D**  $\diamond\diamond$  mm 64 [2.1/2"]  
**Cromo** / Chrome  
**Nikmatt** / Satin Nickel



# A 289

design Giancarlo Vegni

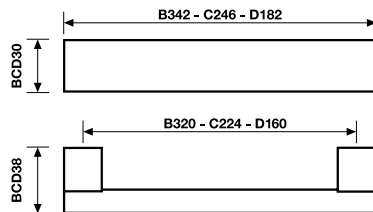

**Nikrall Lega Zama UNI 3717 e Ottone**  
Nikrall Zamak Alloy UNI 3717 and Brass

**B**  $\diamond\diamond$  mm 320 [12.5/8"]

**Nikmatt** / Satin Nickel

**C**  $\diamond\diamond$  mm 224 [8.3/16"]

**Nikmatt** / Satin Nickel

**D**  $\diamond\diamond$  mm 160 [6.3/8"]

**Nikmatt** / Satin Nickel



# A 288

design Giancarlo Vegni

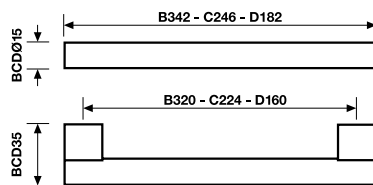

**Nikrall Lega Zama UNI 3717 e Ottone**  
Nikrall Zamak Alloy UNI 3717 and Brass

**B**  $\diamond\diamond$  mm 320 [12.5/8"]

**Alu 7011**

**Nikmatt** / Satin Nickel

**C**  $\diamond\diamond$  mm 224 [8.13/16"]

**Alu 7011**

**Nikmatt** / Satin Nickel

**D**  $\diamond\diamond$  mm 160 [6.3/8"]

**Alu 7011**

**Nikmatt** / Satin Nickel

# A 284

design Eero Aarnio

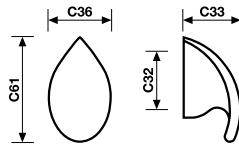

**Nikrall Lega Zama UNI 3717** / Nikrall Zamak Alloy UNI 3717

**C**  $\diamond\diamond$  mm 32 [1.1/4"]

**Cromo** / Chrome

**Nikmatt** / Satin Nickel

# A 283

design Valli Workshop

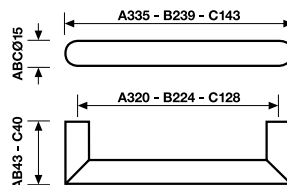

**Acciaio Inox** / Stainless Steel

**A**  $\diamond\diamond$  mm 320 [12.5/8"]

**Satinato** / Satin

**B**  $\diamond\diamond$  mm 224 [8.13/16"]

**Satinato** / Satin

**C**  $\diamond\diamond$  mm 128 [5"]

**Satinato** / Satin

# A 282

design Valli Workshop

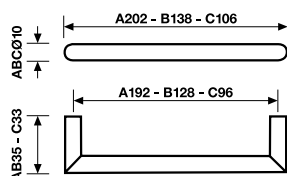

**Acciaio Inox** / Stainless Steel

**A**  $\diamond\diamond$  mm 192 [7.9/16"]

**Satinato** / Satin

**B**  $\diamond\diamond$  mm 128 [5"]

**Satinato** / Satin

**C**  $\diamond\diamond$  mm 96 [3.3/4"]

**Satinato** / Satin



# A 281

design Valli Workshop

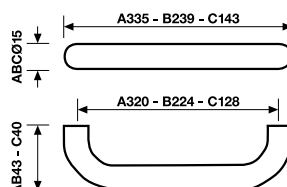

**Acciaio Inox** / Stainless Steel

**A**  $\diamond\diamond$  mm 320 [12.5/8"]

**Satinato** / Satin

**B**  $\diamond\diamond$  mm 224 [8.13/16"]

**Satinato** / Satin

**C**  $\diamond\diamond$  mm 128 [6.3/8"]

**Satinato** / Satin





# A 280

design Valli Workshop

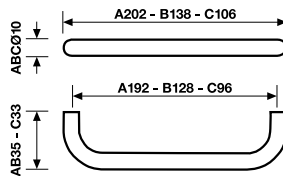

**Acciaio Inox** / Stainless Steel

**A**  $\diamond\diamond$  mm 192 [7.9/16"]

**Satinato** / Satin

**B**  $\diamond\diamond$  mm 128 [5"]

**Satinato** / Satin

**C**  $\diamond\diamond$  mm 96 [3.3/4"]

**Satinato** / Satin

# A 278

design Eero Aarnio

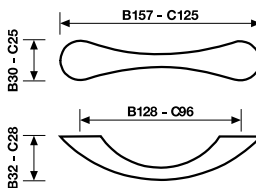

**Nikrall Lega Zama UNI 3717** / Nikrall Zamak Alloy UNI 3717

**B**  $\diamond\diamond$  mm 128 [5"]

**Nikmatt** / Satin Nickel

**C**  $\diamond\diamond$  mm 96 [3.3/4"]

**Nikmatt** / Satin Nickel

# A 275

design Valli Workshop

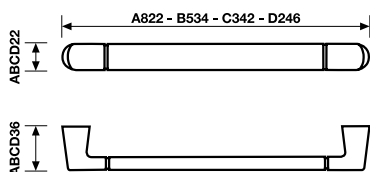

**Ottone e Nikrall Lega Zama UNI 3717**

Ottone Nikrall Zamak Alloy UNI 3717

**A**  $\diamond\diamond$  mm 800 [31.1/2"]

**Nikmatt** / Satin Nickel

**B**  $\diamond\diamond$  mm 512 [20.1/8"]

**Nikmatt** / Satin Nickel

**C**  $\diamond\diamond$  mm 320 [12.5/8"]

**Nikmatt** / Satin Nickel

**D**  $\diamond\diamond$  mm 224 [8.13/16"]

**Nikmatt** / Satin Nickel



# A 262

design Alan Gordon Morris

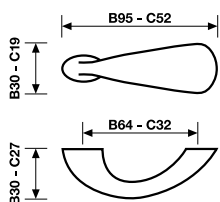

**Nikrall Lega Zama UNI 3717** / Nikrall Zamak Alloy UNI 3717

**B**  $\diamond\diamond$  mm 64 [2.1/2"]

**Nikmatt** / Satin Nickel

**C**  $\diamond\diamond$  mm 32 [1.1/4"]

**Nikmatt** / Satin Nickel

# A 256

design Eero Aarnio

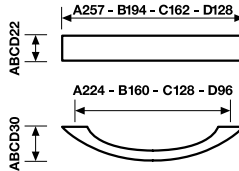

**Nikrall Lega Zama UNI 3717** / Nikrall Zamak Alloy UNI 3717

**A**  $\diamond\diamond$  mm 224 [8.13/16"]

**Nikmatt** / Satin Nickel

**B**  $\diamond\diamond$  mm 160 [6.5/16"]

**Nikmatt** / Satin Nickel

**C**  $\diamond\diamond$  mm 128 [5"]

**Nikmatt** / Satin Nickel

**D**  $\diamond\diamond$  mm 96 [3.3/4"]

**Nikmatt** / Satin Nickel

# A 252

design Eero Aarnio

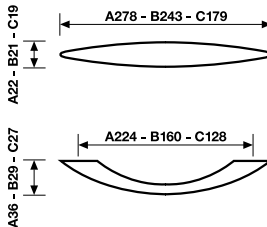

**Nikrall Lega Zama UNI 3717** / Nikrall Zamak Alloy UNI 3717

**A**  $\diamond\diamond$  mm 224 [8.13/16"]

**Nikmatt** / Satin Nickel

**B**  $\diamond\diamond$  mm 160 [6.5/16"]

**Nikmatt** / Satin Nickel

**C**  $\diamond\diamond$  mm 128 [5"]

**Nikmatt** / Satin Nickel



# A 251

design Gost & Schreyer

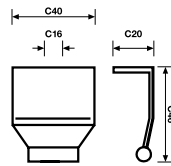

**Nikrall Lega Zama UNI 3717** / Nikrall Zamak Alloy UNI 3717

**C**  $\diamond\diamond$  mm 16 [5/8"]

**Cromo** / Chrome

**Light Grey**

# A 250

design Gost & Schreyer

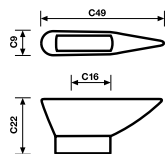

**Nikrall Lega Zama UNI 3717** / Nikrall Zamak Alloy UNI 3717

**C**  $\diamond\diamond$  mm 16 [5/8"]

**Nikmatt** / Satin Nickel

# A 246

design Eero Aarnio

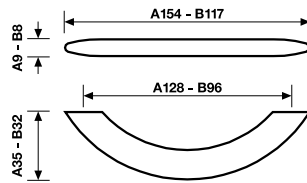

**Nikrall Lega Zama UNI 3717** / Nikrall Zamak Alloy UNI 3717

**A** ⇄ mm 128 [5"]

**Nikmatt** / Satin Nickel

**B** ⇄ mm 96 [3.3/4"]

**Nikmatt** / Satin Nickel

# A 240

design Eero Aarnio

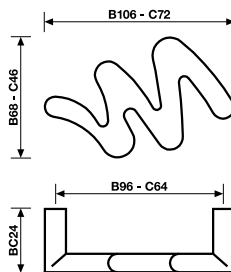

**Nikrall Lega Zama UNI 3717** / Nikrall Zamak Alloy UNI 3717

**B** ⇄ mm 96 [3.3/4"]

**Cromo** / Chrome

**Light Grey**

**C** ⇄ mm 64 [2.1/2"]

**Cromo** / Chrome

**Light Grey**

# A 239

design Eero Aarnio

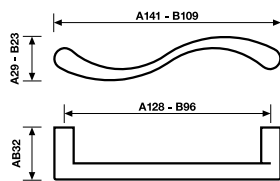

**Nikrall Lega Zama UNI 3717** / Nikrall Zamak Alloy UNI 3717

**A**  $\diamond\diamond$  mm 128 [5"]  
**Nikmatt** / Satin Nickel

**B**  $\diamond\diamond$  mm 96 [3.3/4"]  
**Nikmatt** / Satin Nickel



# A 237

design Eero Aarnio

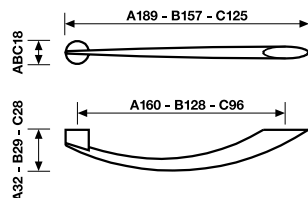

**Nikrall Lega Zama UNI 3717** / Nikrall Zamak Alloy UNI 3717

**A**  $\diamond\diamond$  mm 160 [6.5/16"]  
**Nikmatt** / Satin Nickel

**B**  $\diamond\diamond$  mm 128 [5"]  
**Nikmatt** / Satin Nickel

**C**  $\diamond\diamond$  mm 96 [3.3/4"]  
**Nikmatt** / Satin Nickel



# A 236

design Eero Aarnio

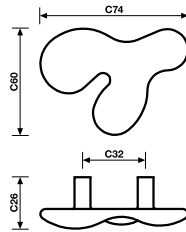

**Nikrall Lega Zama UNI 3717 / Nikrall Zamak Alloy UNI 3717**

**C**  $\diamond$   $\diamond$  mm 32 [1.1/4"]  
**Cromo / Chrome**  
**Light Grey**

# A 235

design Eero Aarnio

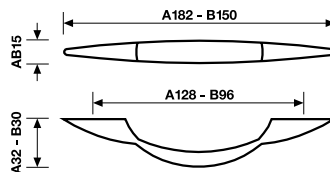

**Nikrall Lega Zama UNI 3717 / Nikrall Zamak Alloy UNI 3717**

**A**  $\diamond$   $\diamond$  mm 128 [5"]  
**Light Grey**

**B**  $\diamond$   $\diamond$  mm 96 [3.3/4"]  
**Light Grey**

# A 232

design Martin Szekely

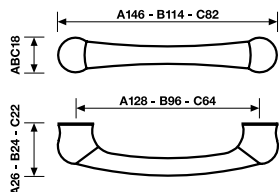

Nikrall Lega Zama UNI 3717 / Nikrall Zamak Alloy UNI 3717

**A**  $\diamond\diamond$  mm 128 [5"]

**Nikmatt** / Satin Nickel

**Orolux** / Brass Plated

**B**  $\diamond\diamond$  mm 96 [3.3/4"]

**Nikmatt** / Satin Nickel

**Orolux** / Brass Plated

**C**  $\diamond\diamond$  mm 64 [2.1/2"]

**Nikmatt** / Satin Nickel

**Orolux** / Brass Plated



# A 231

design Valli Workshop



Nikrall Lega Zama UNI 3717 / Nikrall Zamak Alloy UNI 3717

**A**  $\diamond\diamond$  mm 320 [12.5/8"]

**Nikmatt** / Satin Nickel

**B**  $\diamond\diamond$  mm 224 [8.13/16"]

**Nikmatt** / Satin Nickel

**C**  $\diamond\diamond$  mm 128 [5"]

**Nikmatt** / Satin Nickel





# A 230

design Valli Workshop

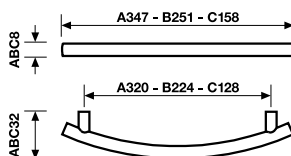

**Nikrall Lega Zama UNI 3717** / Nikrall Zamak Alloy UNI 3717

**A**  $\diamond$  **mm 320** [12.5/8"]

**Nikmatt** / Satin Nickel

**B**  $\diamond$  **mm 224** [8.13/16"]

**Nikmatt** / Satin Nickel

**C**  $\diamond$  **mm 128** [5"]

**Nikmatt** / Satin Nickel

# A 163

design Sottsass Associati

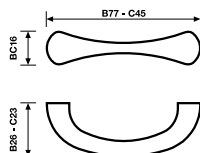

**Ottone** / Brass

**B**  $\diamond$  **mm 96** [2.1/2"]

**Cromsatin** / Satin Chrome

**Oro Lucido** / Polished Brass

**C**  $\diamond$  **mm 64** [1.1/4"]

**Cromsatin** / Satin Chrome

**Oro Lucido** / Polished Brass

# A 157

design Valli Workshop

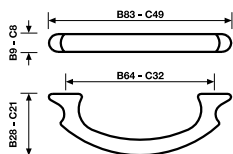

**Ottone** / Brass

**B**  $\diamond\diamond$  mm 64 [2.1/2"]

**Oro** / Brass

**Patiné** / Antique Brass

**C**  $\diamond\diamond$  mm 32 [1.1/4"]

**Oro** / Brass

**Patiné** / Antique Brass



# A 138 P

design Valli Workshop

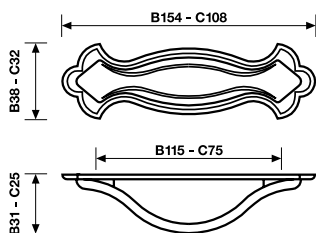

**Ottone** / Brass

**B**  $\diamond\diamond$  mm 115 [4.1/2"]

**Patiné** / Antique Brass

**C**  $\diamond\diamond$  mm 75 [2.15/16"]

**Patiné** / Antique Brass



# A 792

design Valli Workshop

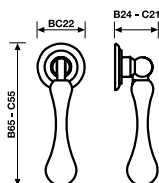

**Ottone** / Brass

**B**  $\diamond$   $\diamond$  **mm 65** [2.9/16"]

**Oro** / Brass

**Patiné** / Antique Brass

**C**  $\diamond$   $\diamond$  **mm 55** [2.1/8"]

**Oro** / Brass

**Patiné** / Antique Brass

# A 791

design Valli Workshop

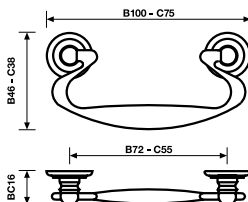

**Ottone** / Brass

**B**  $\diamond$   $\diamond$  **mm 72** [2.9/16"]

**Oro** / Brass

**Patiné** / Antique Brass

**C**  $\diamond$   $\diamond$  **mm 55** [2.1/8"]

**Oro** / Brass

**Patiné** / Antique Brass

# A 770/2

design Valli Workshop

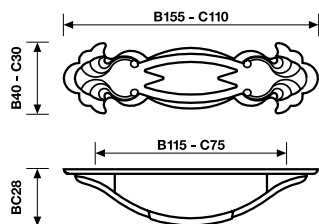

**Ottone** / Brass

**A**  $\diamond\diamond$  mm 170 [6.7/8"]

**Patiné** / Antique Brass

**B**  $\diamond\diamond$  mm 115 [4.1/2"]

**Patiné** / Antique Brass

**C**  $\diamond\diamond$  mm 75 [2.15/16"]

**Patiné** / Antique Brass



# A 767

design Valli Workshop

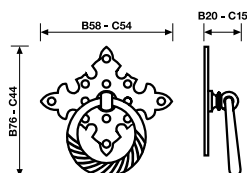

**Nikrall Lega Zama UNI 3717 e Ferro Battuto**

Nikrall Zamak Alloy UNI 3717 and Wrought Iron

**B** mm 76 [3"]

**Fumé** / Iron

**C** mm 44 [1.3/4"]

**Fumé** / Iron



# A 755/2

design Valli Workshop

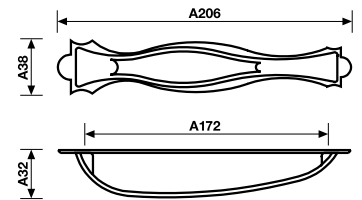
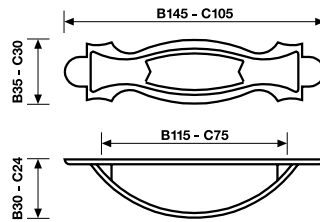

Ottone / Brass

**A**  $\diamond\diamond$  mm 172 [6.7/8"]  
**Patiné** / Antique Brass

**B**  $\diamond\diamond$  mm 115 [4.1/2"]  
**Patiné** / Antique Brass

**C**  $\diamond\diamond$  mm 75 [2.15/16"]  
**Patiné** / Antique Brass

# A 753/2

design Valli Workshop

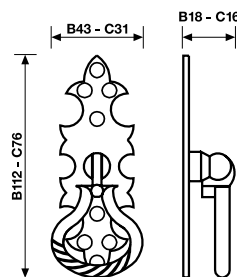

**Nikrall Lega Zama UNI 3717 e Ferro Battuto**  
 Nikrall Zamak Alloy UNI 3717 and Wrought Iron

**B** mm 112 [4.7/16"]  
**Fumé** / Iron

**C** mm 76 [3"]  
**Fumé** / Iron

# A 752/2

design Valli Workshop

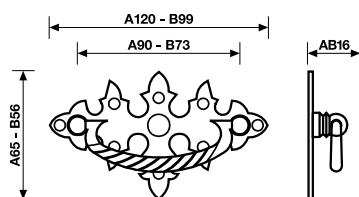

**Nikrall Lega Zama UNI 3717 e Ferro Battuto**

Nikrall Zamak Alloy UNI 3717 and Wrought Iron

**A**  $\diamond\diamond$  mm 90 [4.7/16"]

**Fumé** / Iron

**B**  $\diamond\diamond$  mm 73 [3"]

**Fumé** / Iron



# A 738/2

design Valli Workshop

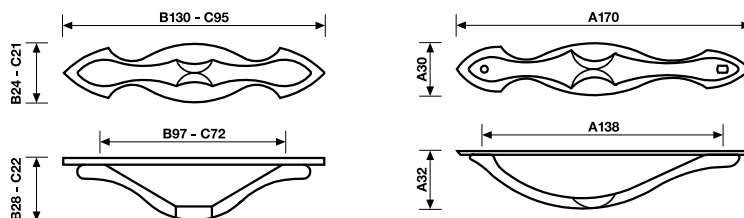

**Ottone** / Brass

**A**  $\diamond\diamond$  mm 138 [5.3/8"]

**Oro** / Brass

**B**  $\diamond\diamond$  mm 97 [3.13/16"]

**Oro** / Brass

**C**  $\diamond\diamond$  mm 72 [2.13/16"]

**Oro** / Brass

# B 308

design Valli Workshop

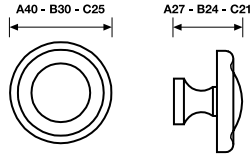

**Ottone** / Brass

**A** Ømm 40 [1.9/16"]

**Oro** / Brass

**Patiné** / Antique Brass

**B** Ømm 30 [1.3/16"]

**Oro** / Brass

**Patiné** / Antique Brass

**C** Ømm 25 [1"]

**Oro** / Brass

**Patiné** / Antique Brass

# B 276

design Antonio Citterio

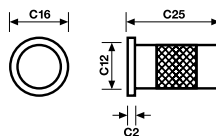

**Acciaio Inox** / Stainless Steel

**C** Ømm 16 [5/8"]

**Satinato** / Satin

# B 275

design Leon Krier

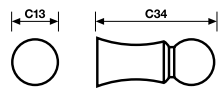

**Ottone** / Brass

**C** Ømm 13 [1/2"]

**Arant** / Antique Silver

**Orantop** / Antique Matt Gold

**Orolux** / Brass Plated

# B 274

design Valli Workshop

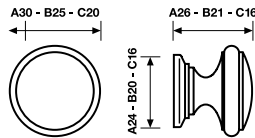

**Ottone** / Brass

**A** Ømm 30 [1.3/16"]

**Oro Lucido** / Polished Brass

**Cromsatin** / Satin Chrome

**Anticato** / Antique

**B** Ømm 25 [1"]

**Oro Lucido** / Polished Brass

**Cromsatin** / Satin Chrome

**Anticato** / Antique

**C** Ømm 20 [13/16"]

**Oro Lucido** / Polished Brass

**Cromsatin** / Satin Chrome

**Anticato** / Antique





# B 273

design Valli Workshop

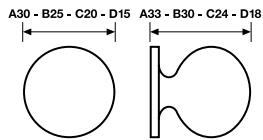

**Ottone** / Brass

- A** Ømm 30 [1.3/16"]
- Oro Lucido** / Polished Brass
- Cromo** / Chrome
- Cromsatin** / Satin Chrome
- B** Ømm 25 [1"]
- Oro Lucido** / Polished Brass
- Cromo** / Chrome
- Cromsatin** / Satin Chrome
- C** Ømm 20 [13/16"]
- Oro Lucido** / Polished Brass
- Cromo** / Chrome
- Cromsatin** / Satin Chrome
- D** Ømm 15 [9/16"]
- Oro Lucido** / Polished Brass
- Cromo** / Chrome
- Cromsatin** / Satin Chrome

# B 272

design Valli Workshop

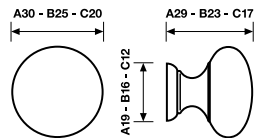

**Ottone** / Brass

- A** Ømm 30 [1.3/16"]
- Oro Lucido** / Polished Brass
- Cromsatin** / Satin Chrome
- Anticato** / Antique
- B** Ømm 25 [1"]
- Oro Lucido** / Polished Brass
- Cromsatin** / Satin Chrome
- Anticato** / Antique
- C** Ømm 20 [13/16"]
- Oro Lucido** / Polished Brass
- Cromsatin** / Satin Chrome
- Anticato** / Antique

# B 271

design Valli Workshop

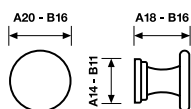

**Ottone** / Brass

**A** Ømm 20 [13/16"]  
**Oro Lucido** / Polished Brass  
**Cromo** / Chrome  
**Cromsatin** / Satin Chrome  
**B** Ømm 15 [9/16"]  
**Oro Lucido** / Polished Brass  
**Cromo** / Chrome  
**Cromsatin** / Satin Chrome



# B 270

design Valli Workshop

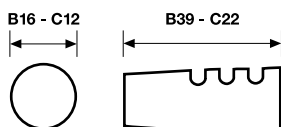

**Ottone** / Brass

**B** Ømm 16 [5/8"]  
**Cromo** / Chrome  
**Cromsatin** / Satin Chrome  
**C** Ømm 12 [7/16"]  
**Cromo** / Chrome  
**Cromsatin** / Satin Chrome



# B 266

design Andrée Putman

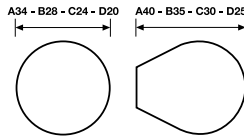

**Ottone** / Brass

**A** Ømm 34 [1.3/16"]

**Cromo** / Chrome

**Cromsatin** / Satin Chrome

**B** Ømm 28 [1.1/8"]

**Cromo** / Chrome

**Cromsatin** / Satin Chrome

**C** Ømm 24 [15/16"]

**Cromo** / Chrome

**Cromsatin** / Satin Chrome

**D** Ømm 20 [13/16"]

**Cromo** / Chrome

**Cromsatin** / Satin Chrome

# B 250

design Alan Gordon Morris

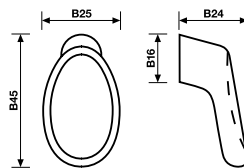

**Nikrall Lega Zama UNI 3717** / Nikrall Zamak Alloy UNI 3717

**B** Ømm 25 [1"]

**Nikmatt** / Satin Nickel

**Orolux** / Brass Plated

# B 249

design Gost & Schreyer

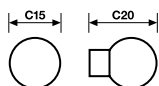

**Ottone** / Brass

**C** Ømm 15 [9/16"]

**Cromo** / Chrome

**Nikmatt** / Satin Nickel



# B 248

design Gost & schreyer

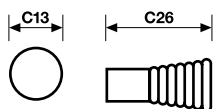

**Ottone** / Brass

**C** Ømm 13 [1/2"]

**Oro Lucido** / Polished Brass

**Cromo** / Chrome

**Nikmatt** / Satin Nickel



# B 246

design Eero Aarnio

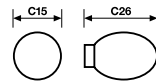

**Ottone** / Brass

**C** Ømm 15 [9/16"]

**Nikmatt** / Satin Nickel

# B 245

design Eero Aarnio

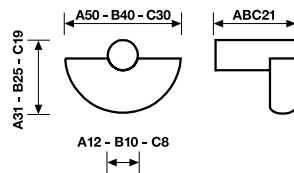

**Ottone** / Brass

**A** Ømm 50 [2"]

**Nikmatt-Cromo** / Nikmatt-Chrome

**B** Ømm 40 [1.9/16"]

**Nikmatt-Cromo** / Nikmatt-Chrome

**C** Ømm 30 [1.3/16"]

**Nikmatt-Cromo** / Nikmatt-Chrome

# B 244

design Eero Aarnio

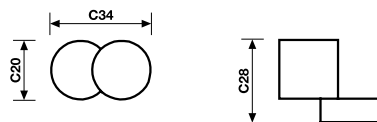

**Nikrall Lega Zama UNI 3717** / Nikrall Zamak Alloy UNI 3717

**C** Ømm 20 [13/16"]

**Nikmatt** / Satin Nickel



# B 242

design Eero Aarnio

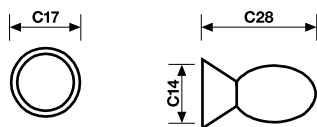

**Ottone** / Brass

**C** Ømm 14 [11/16"]

**Cromo** / Chrome

**Nikmatt** / Satin Nickel

**Oro Lucido** / Polished Brass



# B 241

design Valli Workshop

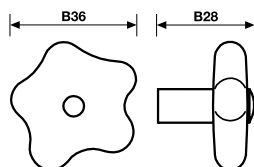

**Vetro di Murano e Ottone** / Murano Glass and Brass

**B mm 36 [1.7/16"]**

**Azzurro opaco-Nikmatt** / Matt sky-blue-Nikmatt

**Blu opaco-Nikmatt** / Matt blue-Nikmatt

**Rosa opaco-Nikmatt** / Matt rose-Nikmatt

**Satinato-Nikmatt** / Satin-Nikmatt

**Topazio opaco-Nikmatt** / Matt topaz-Nikmatt

**Verde opaco-Nikmatt** / Matt green-Nikmatt

**Azzurro opaco-Oro** / Matt sky-blue-Brass

**Blu opaco-Oro** / Matt blue-Brass

**Rosa opaco-Oro** / Matt rose-Brass

**Satinato-Oro** / Satin-Brass

**Topazio opaco-Oro** / Matt topaz-Brass

**Verde opaco-Oro** / Matt green-Brass

# B 240

design Gost & Schreyer

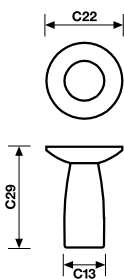

**Ottone** / Brass

**C Ømm 13 [7/8"]**

**Nikmatt** / Nikmatt

# B 239

design Gost & Schreyer

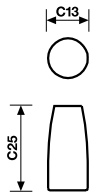

**Ottone** / Brass

**C** Ø mm 13 [1/2"]

**Cromo** / Chrome

**Nikmatt** / Nikmatt



# B 238

design Martin Szekely

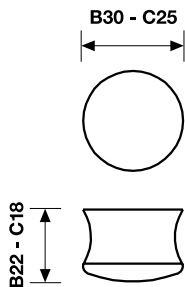

**Ottone** / Brass

**B** Ø mm 30 [1.3/16"]

**Nikmatt** / Satin Nickel

**C** Ø mm 25 [1"]

**Nikmatt** / Satin Nickel





# B 237

design Valli Workshop

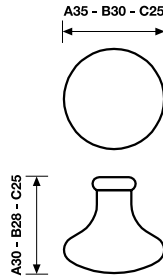

**Porcellana e Ottone** / Porcelain and Brass

- A** Ø mm 35 [1.3/8"]
- Bianco** / White
- Fiorato** / Floral
- B** Ø mm 30 [1.3/16"]
- Bianco** / White
- Fiorato** / Floral
- C** Ø mm 25 [1"]
- Bianco** / White
- Fiorato** / Floral

# B 228

design Valli Workshop

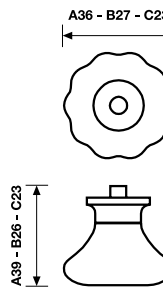

**Vetro e Ottone** / Glass and Brass

- A** Ø mm 36 [1.7/16"]
- Trasparente** / Transparent
- B** Ø mm 27 [1.1/16"]
- Trasparente** / Transparent
- C** Ø mm 23 [7/8"]
- Trasparente** / Transparent

# B 137

design Antonio Citterio

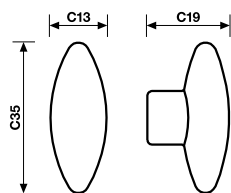

**Ottone** / Brass

**C** mm 35 [1.3/8"]

**Cromo** / Chrome

**Cromsatin** / Satin Chrome



# B 133

design Valli Workshop

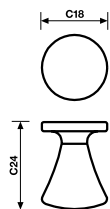

**Ottone** / Brass

**C** Ømm 18 [11/16"]

**Oro** / Brass

**Cromsatin** / Satin Chrome



# B 128

design Valli Workshop

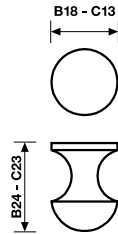

**Ottone** / Brass

**B** Ømm 18 [11/16"]

**Bianco** / White

**Oro** / Brass

**Patiné** / Antique Brass

**C** Ømm 13 [1/2"]

**Bianco** / White

**Oro** / Brass

**Patiné** / Antique Brass

# B 120

design Valli Workshop

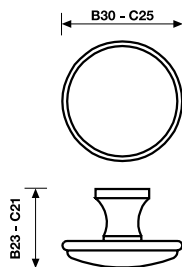

**Ottone** / Brass

**B** Ømm 30 [1.3/16"]

**Oro** / Brass

**Patiné** / Antique Brass

**C** Ømm 25 [1"]

**Oro** / Brass

**Patiné** / Antique Brass

# B 33

design Gregotti Associati

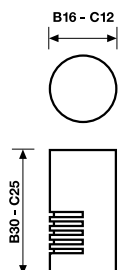

**Ottone** / Brass

**B** Ømm 16 [5/8"]

**Cromo** / Chrome

**Cromsatin** / Satin Chrome

**Oro** / Brass

**C** Ømm 12 [7/16"]

**Cromo** / Chrome

**Cromsatin** / Satin Chrome

**Oro** / Brass



# B 985

design Valli Workshop

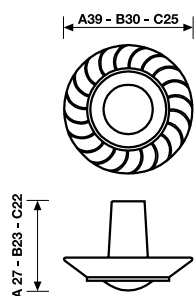

**Nikrall Lega Zama UNI 3717 e Ferro Battuto**

Nikrall Zamak Alloy UNI 3717 and Wrought Iron

**B** Ømm 30 [1.3/16"]

**Fumé** / Iron

**C** Ømm 25 [1"]

**Fumé** / Iron

# B 985 PL

design Valli Workshop

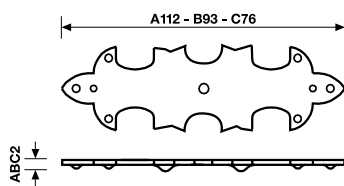

**Ferro** / Iron

**B** Ømm 93 [3.5/8"]

**Fumé** / Iron

**C** Ømm 76 [3"]

**Fumé** / Iron

# C 791

design Valli Workshop

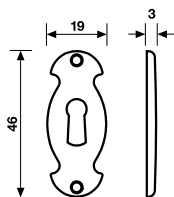

**Ottone** / Brass

**Oro** / Brass

**Patiné** / Antique Brass



# C 753

design Valli Workshop

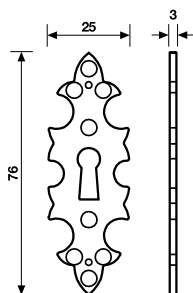

**Ferro** / Iron

**Fumé** / Iron



# C 117

design Valli Workshop

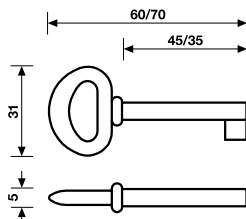

**Ottone** / Brass

**C 117**

**Oro** / Brass

**Patiné** / Antique Brass

**C 117/45**

**Oro** / Brass

**Patiné** / Antique Brass

# C 113

design Valli Workshop

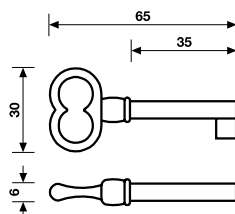

**Ottone** / Brass

**Oro** / Brass

**Patiné** / Antique Brass

# C 52

design Valli Workshop

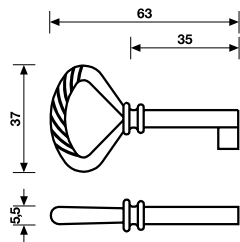

**Nikrall Lega Zama UNI 3717** / Nikrall Zamak Alloy UNI 3717

**Fumé** / Iron





# DCRN 752

design Valli Workshop

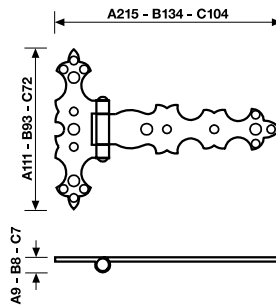
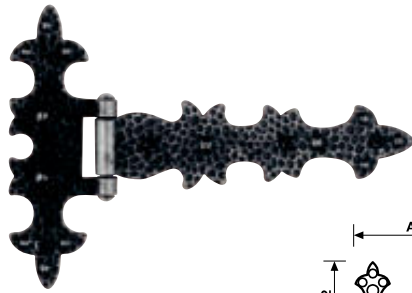

Ferro / Iron

## DCRN 752

**A 215/111 P.9** [8.1/2"] / [4.3/8"]

Fumé / Iron

**B 134/93 P.8** [5.1/4"] / [3.5/8"]

Fumé / Iron

**C 104/72 P.7** [1.1/8"] / [2.7/8"]

Fumé / Iron

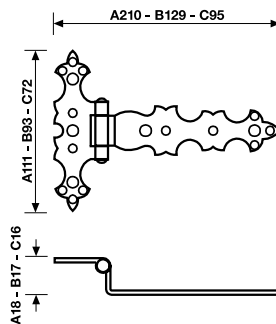

## DCRN 752/12

**A 210/111 P.18** [8.1/4"] / [4.3/8"]

Fumé / Iron

**B 129/93 P.17** [5.1/8"] / [3.5/8"]

Fumé / Iron

**C 95/72 P.16** [3.3/4"] / [2.7/8"]

Fumé / Iron

# DCRN 152

design Valli Workshop

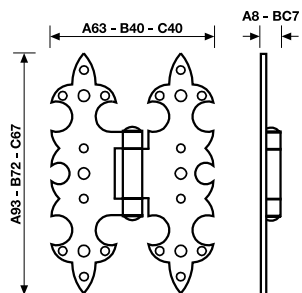

Ferro / Iron

## DCRN 152

**A 93/63 P.8** [3.5/8"] / [2.1/2"]

Fumé / Iron

**B 72/40 P.7** [2.7/8"] / [1.5/8"]

Fumé / Iron

**C 67/40 P.7** [2.5/8"] / [1.5/8"]

Fumé / Iron

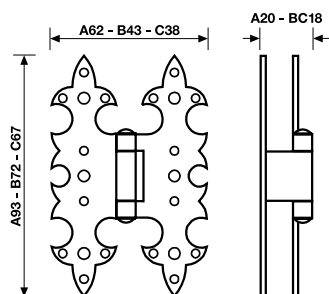

## DCRN 152/12

**A 93/62 P.20** [3.5/8"] / [1.1/2"]

Fumé / Iron

**B 72/43 P.18** [2.7/8"] / [1.3/4"]

Fumé / Iron

**C 67/38 P.18** [2.5/8"] / [1.1/2"]

Fumé / Iron





Complementari e sistemi di fissaggio  
Complementary accessories and fixing systems





## X 0610

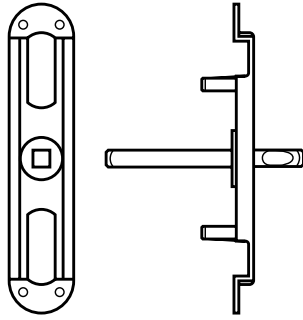

**Movimento MP/7**  
Movement

**Acciaio Zincato / Zinc Steel**

## X 0609

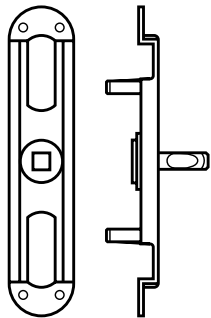

**Movimento MP**  
Movement

**Acciaio Zincato / Zinc Steel**

## X 0607

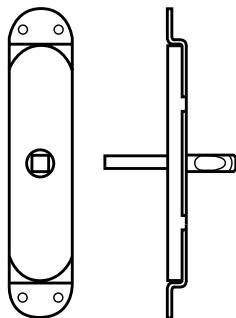

**Movimento Martellina**  
Movement

**Acciaio Zincato / Zinc Steel**

# X 0606

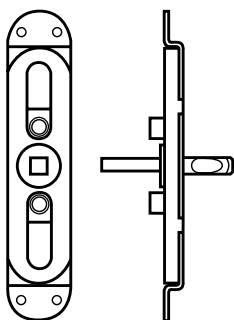

**Movimento Gratz/7**  
Movement

**Acciaio Zincato** / Zinc Steel

# X 0605

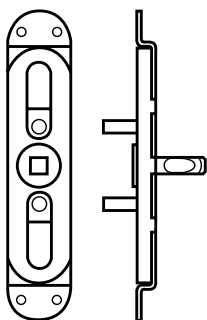

**Movimento Gratz CP**  
Movement

**Acciaio Zincato** / Zinc Steel

# X 0604

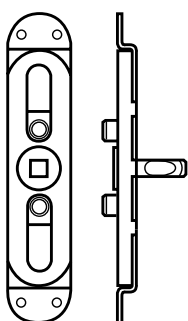

**Movimento Gratz**  
Movement

**Acciaio Zincato** / Zinc Steel





## X 0601

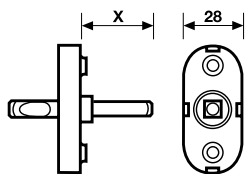

### Movimento 4 Scatti

Movement

Acciaio Zincato / Zinc Steel

## X 0551

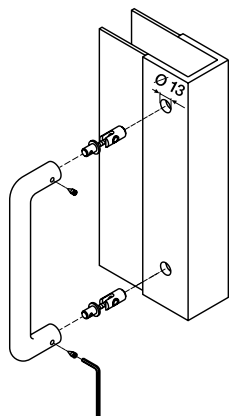

### Per fissaggio singolo maniglione senza rosette coprivite su porta blindata antieffrazione per art.

For fixing a single pull handle without rosettes on a burglary-proof steel-clad door, for art.

K 1228 - K 1227 - K 1226 - K 1218 - K 1216 - K1210 - K 1209

## X 0544

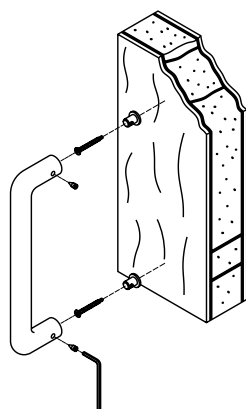

### Per fissaggio singolo maniglione senza rosette coprivite su porta blindata antieffrazione per art.

For fixing a single pull handle without rosettes on a burglary-proof steel-clad door, for art.

K 1228 - K 1227 - K 1226 - K 1218 - K 1216 - K1210 - K 1209

## X 0531

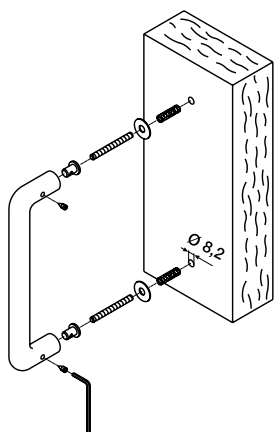

**Per fissaggio singolo maniglione senza rosette coprivite su porta legno o parete in muratura con bussola ad espansione in ottone per art.**

For fixing a single pull handle without rosettes on a wooden door or on a masonry wall using a brass anchor screw for art

**K 1228 - K 1227 - K 1226 - K 1218 - K 1216 - K1210 - K 1209**

## X 0530

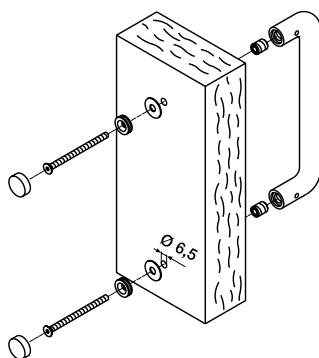

**Per fissaggio singolo maniglione senza rosette coprivite su porta legno spessore 45÷55 mm, 55÷65 mm per art.**

For fixing a single pull handle without rosettes on a wooden door, thickness 45÷55 mm 55÷65 mm, for art

**K 1228 - K 1227 - K 1226 - K 1218 - K 1216 - K1210 - K 1209**

## X 0529

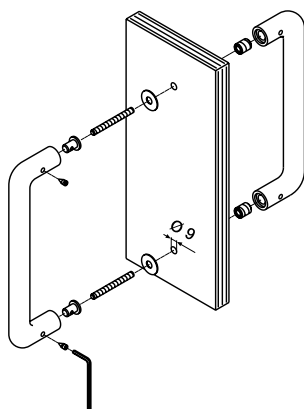

**Per fissaggio coppia maniglioni senza rosette coprivite su porta vetro spessore 8÷12 mm per art.**

For fixing a pair of pull handles without rosettes on a glass door, thickness 8÷12 mm for art.

**K 1228 - K 1227 - K 1226 - K 1218 - K 1216 - K1210 - K 1209**







## X 0528

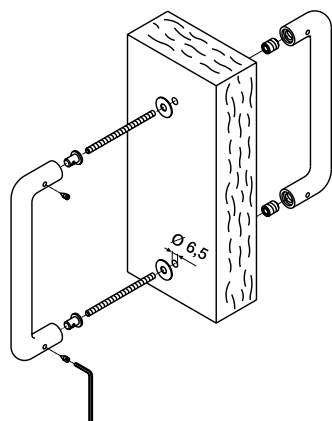

**Per fissaggio coppia maniglioni senza rosette coprivite su porta legno spessore 45÷55 mm 55÷65 mm, per art.**

For fixing a pair of pull handles without rosettes on a wooden door, thickness 45÷55 mm 55÷65 mm, for art.

**K 1228 - K 1227 - K 1226 - K 1218 - K 1216 - K1210 - K 1209**

## X 0527

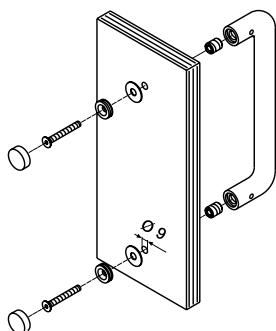

**Per fissaggio singolo maniglione senza rosette coprivite su porta vetro spessore 8÷12 mm, per art.**

For fixing a single pull handle without rosettes on a glass door, thickness 8÷12 mm for art.

**K 1228 - K 1227 - K 1226 - K 1218 - K 1216 - K1210 - K 1209**

## X 0526

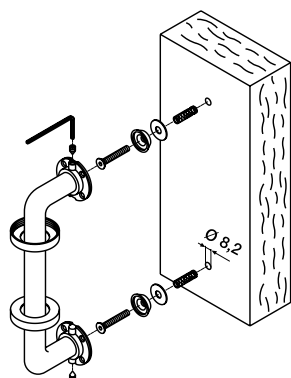

**Per fissaggio singolo maniglione con rosette coprivite su porta legno o parete in muratura con bussola ad espansione in ottone per art.**

For fixing a single pull handle with rosettes on a wooden door or on a masonry wall using a brass anchor screw for art.

**K 1218 - K 1210 - K 1209 - K 1207 - K 1188 - K 1181**

## X 0525

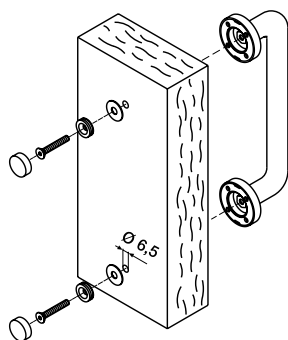

**Per fissaggio singolo maniglione con rosette coprivite su porta legno spessore 45÷55 mm 55÷65 mm, per art.**

For fixing a single pull handle with rosettes on a wooden door, thickness 45÷55 mm 55÷65 mm, for art.

**K 1218 - K 1210 - K 1209 - K 1207 - K 1188 - K 1181**

## X 0524

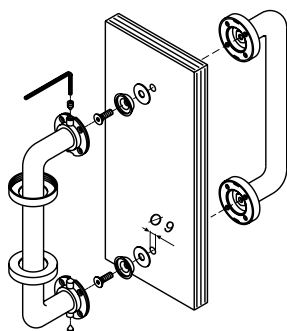

**Per fissaggio coppia maniglioni con rosette coprivite su porta vetro spessore 8÷12 mm per art.**

For fixing a pair of pull handles with rosettes on a glass door, thickness 8÷12 mm for art.

**K 1218 - K 1210 - K 1209 - K 1207 - K 1188 - K 1181**

## X 0523

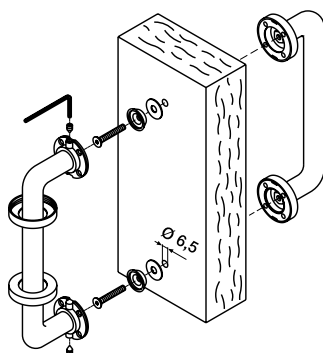

**Per fissaggio coppia maniglioni con rosette coprivite su porta legno spessore 45÷55 mm 55÷65 mm, per art.**

For fixing a pair of pull handles with rosettes on a wooden door, thickness 45÷55 mm 55÷65 mm, for art.

**K 1218 - K 1210 - K 1209 - K 1207 - K 1188 - K 1181**





## X 0522

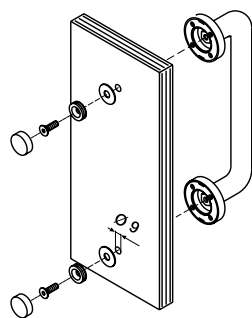

**Per fissaggio singolo maniglione con rosette coprivite su porta vetro spessore 8÷12 mm, per art.**  
For fixing a single pull handle with rosettes on a glass door, thickness 8÷12 mm for art.

**K 1218 - K 1210 - K 1209 - K 1207 - K 1188 - K 1181**

## X 0520

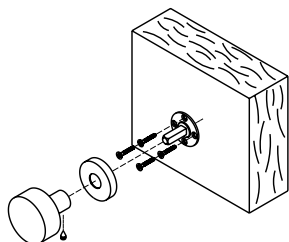

**Per fissaggio pomolo fisso singolo su porte con quadro solidale alla piastrina e viti a legno per art.**  
For fixing a single fixed knob on doors with Taylor spindle and wood screws for art.

**K 1162 - K 1155**

## X 0519

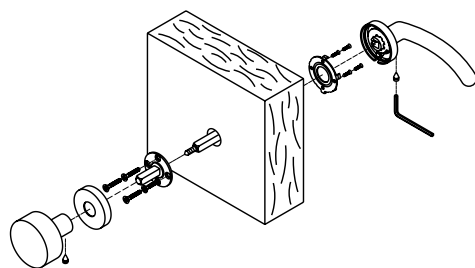

**Per fissaggio pomolo fisso su serratura in coppia con maniglia. Utilizzo di quadro solidale a piastrina per art.**

For fixing a fixed knob with operating lever on Taylor spindle for art.  
**K 1162 - K 1155**

# X 0518

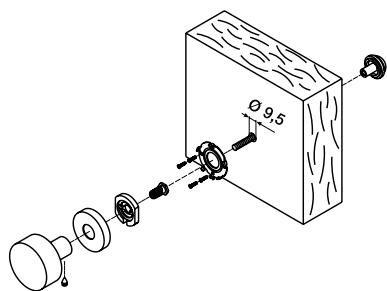

**Per fissaggio pomolo singolo fisso con dado/copridado passante per art.**

For fixing a single fixed knob with through bolt/bolt-cover for art.  
K 1162 - K 1155

# X 0517

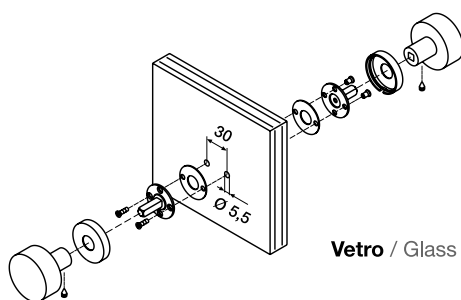

**Vetro / Glass**

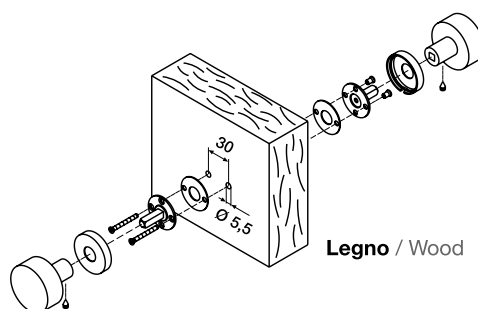

**Legno / Wood**

**Per fissaggio pomoli fissi in coppia su vetro spessore 8÷12 mm e su legno spessore 35÷43 mm per art.**

For fixing a pair of fixed knobs on glass, thickness 8÷12 mm and on wood, thickness 35÷43 mm for art.

K 1162 - K 1155

# X 0516

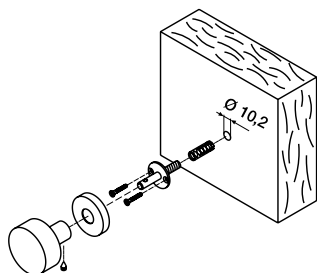

**Per fissaggio pomolo fisso singolo su porte in massello con bussola ad espansione in ottone per art.**

For fixing a single fixed knob on hardwood door using a brass anchor screw for art.

K 1162 - K 1155 - K 1153





## X 0515

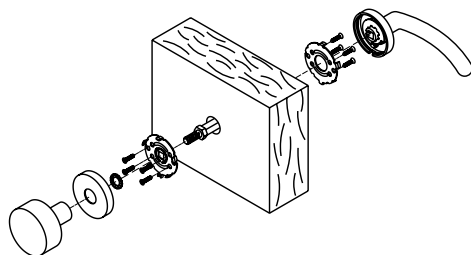

**Per fissaggio pomolo fisso su serratura in coppia con maniglia.  
Utilizzo di quadro filettato girevole per art.**

For fixing a fixed knob with operating lever on rotating threaded spindle for art.

**K 1153**

## X 0514

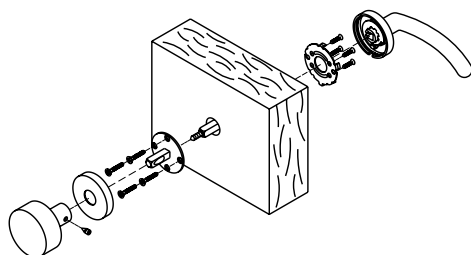

**Per fissaggio pomolo fisso su serratura in coppia con maniglia.  
Utilizzo di quadro solidale a piastrina per art.**

For fixing a fixed knob with operating lever on Taylor spindle for art.

**K 1153**

## X 0513

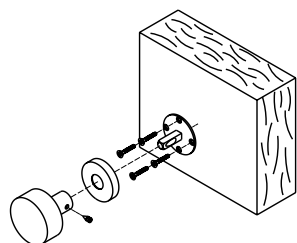

**Per fissaggio pomolo fisso singolo su porte con quadro solidale  
alla piastrina e viti a legno per art.**

For fixing a single fixed knob on doors with Taylor spindle and wood screws for art.

**K 1153**

# X 0512

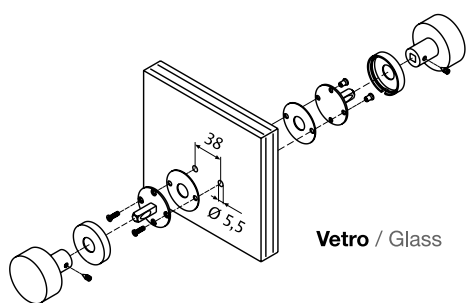

Vetro / Glass

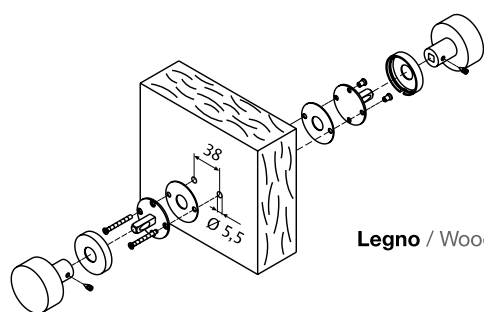

Legno / Wood

**Per fissaggio pomoli fissi in coppia su vetro spessore 8÷12 mm e su legno spessore 35÷43 mm per art.**

For fixing a pair of fixed knobs on glass, thickness 8÷12 mm and on wood, thickness 35÷43 mm for art.

**K 1153**





Valli&amp;Valli

## X 0469/1

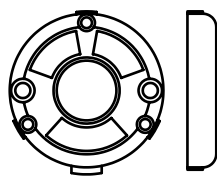

### Nikrall Lega Zama UNI 3717 e Nylon

Nikrall Zamak Alloy UNI 3717 and Nylon

### Sottorosetta *senza molla*, diametro 50 mm, completa di viti per il fissaggio e bussola di centratura

Threaded anchor rosette, *with bi-directional spring*, diameter 50 mm, complete of fixing screws and centering bush

## X 0468/1 DX

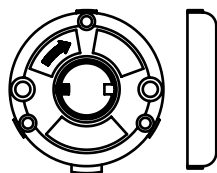

### Nikrall Lega Zama UNI 3717 e Nylon

Nikrall Zamak Alloy UNI 3717 and Nylon

### Sottorosetta *con molla monodirezionale destra*, diametro 50 mm, completa di viti per il fissaggio e bussola di centratura

Threaded anchor rosette, *with bi-directional spring*, diameter 50 mm, complete of fixing screws and centering bush

## X 0468/2 SX

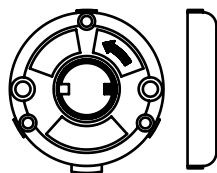

### Nikrall Lega Zama UNI 3717 e Nylon

Nikrall Zamak Alloy UNI 3717 and Nylon

### Sottorosetta *con molla monodirezionale destra*, diametro 50 mm, completa di viti per il fissaggio e bussola di centratura

Threaded anchor rosette, *with bi-directional spring*, diameter 50 mm, complete of fixing screws and centering bush

## X 0446/1

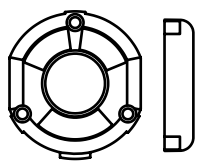

**Nikrall Lega Zama UNI 3717 e Nylon**  
Nikrall Zamak Alloy UNI 3717 and Nylon

**Sottorosetta senza molla, diametro 45 mm, completa di viti per il fissaggio e bussola di centratura**

Threaded anchor rosette, with *bi-directional spring*, diameter 50 mm, complete of fixing screws and centering bush



## X 0445/1 DX

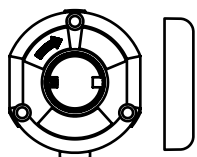

**Nikrall Lega Zama UNI 3717 e Nylon**  
Nikrall Zamak Alloy UNI 3717 and Nylon

**Sottorosetta con molla monodirezionale destra, diametro 45 mm, completa di viti per il fissaggio e bussola di centratura**

Threaded anchor rosette, with *bi-directional spring*, diameter 50 mm, complete of fixing screws and centering bush

## X 0445/2 SX

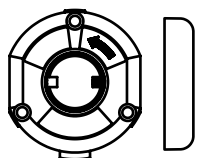

**Nikrall Lega Zama UNI 3717 e Nylon**  
Nikrall Zamak Alloy UNI 3717 and Nylon

**Sottorosetta con molla monodirezionale destra, diametro 45 mm, completa di viti per il fissaggio e bussola di centratura**

Threaded anchor rosette, with *bi-directional spring*, diameter 50 mm, complete of fixing screws and centering bush





Valli&amp;Valli

## X 0511

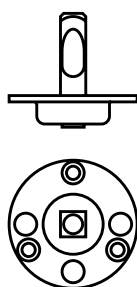
**Ferro** / Iron**Per fissaggio pomolo fisso senza foro passante**  
For fixing a fixed knob without through holes**Acciaio Zincato** / Zinc Steel

## X 0469 / X 0468

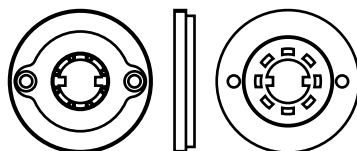
**Nikrall Lega Zama UNI 3717 e Nylon**

Nikrall Zamak Alloy UNI 3717 and Nylon

**X 0469****Sottorosetta filettata senza molla, diametro 50 mm, completa di viti per il fissaggio e bussola di centratura**  
Threaded anchor rosette, *without spring*, diameter 50 mm, complete of fixing screws and centering bush**X 0468****Sottorosetta filettata con molla bidirezionale, diametro 50 mm, completa di viti per il fissaggio e bussola di centratura**  
Threaded anchor rosette, *with bi-directional spring*, diameter 50 mm, complete of fixing screws and centering bush

# X 0446 / 0445

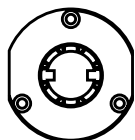

**Nikrall Lega Zama UNI 3717 e Nylon**  
Nikrall Zamak Alloy UNI 3717 and Nylon

## X 0446

**Sottorosetta filettata senza molla, diametro 45 mm, completa di viti per il fissaggio e bussola di centratura**

Threaded anchor rosette, *without spring*, diameter 45 mm, complete of fixing screws and centering bush

## X 0445

**Sottorosetta filettata con molla bidirezionale, diametro 45 mm, completa di viti per il fissaggio e bussola di centratura**

Threaded anchor rosette, *with bi-directional spring*, diameter 45 mm, complete of fixing screws and centering bush



# X 0303

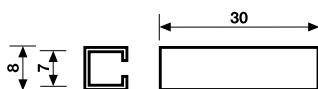

**Ferro / Iron**

**Busoletta**  
Adaptor

# X 0257



**Ferro / Iron**

**Viti 3 x 16 per sottorosetta filettata diametro 45 mm**

Screws 3 x 16 for threaded anchor rosette diameter 45 mm

**Acciaio Zincato / Zinc Steel**

Idonee esclusivamente con nuovo sistema di montaggio, utilizzato per le maniglie da porta con rosetta. / Suitable exclusively for the new mounting system, used for door handles on rosette



## X 0224

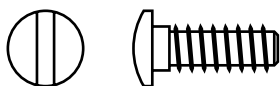

**Ottone** / Brass

**Viti 3,5 MA x 10**  
Screws

**Oro** / Brass

**Oro Zecchino** / Brass Plated

Per Serie / For Series

**Magic® bbeno®**

## X 0222



**Ottone** / Brass

**Viti 3,5 MA x 10**  
Screws

**Oro** / Brass

**Patiné** / Patiné

**Fumé** / Fumé

## X 0215

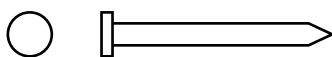

**Acciaio** / Steel

**Chiodini 2 x 20**  
Pins

**Oro** / Brass

**Patiné** / Patiné

# X 0212

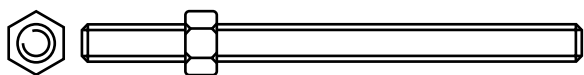

**Ferro** / Iron

**Passante e dado 6 MA x 92**  
Through Bolt

**Zincato** / Zinc Plated



# X 0210

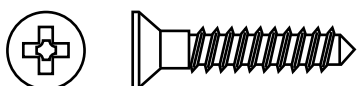

**Ottone** / Brass

**Viti 4,5 x 23 GS**  
Screws

**Oro** / Brass

**Cromo** / Chrome

**Patiné** / Patiné

# X 0209

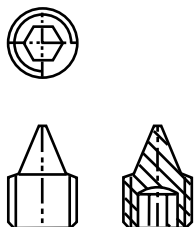

**Acciaio** / Steel

**Grano 6 MA x 9**  
Dowel

**Ottonato** / Brass Plated

**Nero** / Black



Valli&amp;Valli

# X 0208



**Acciaio Zincato / Zinc Steel**

**Chiavi Esagonali 3 mm**  
Hexagonal Keys

# X 0120/8

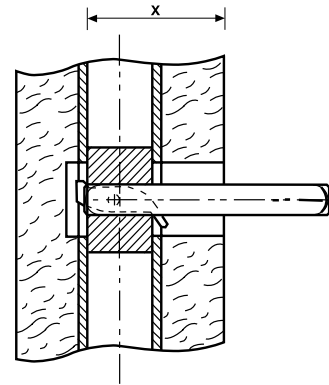
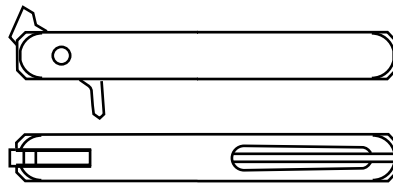

**Acciaio Zincato / Zinc Steel**

**Quadro block per porte forate solo da un lato  $\square$  8**  
Block spindle for doors drilled on one side only

Lunghezza quadro Spindle length	(X) Spessore porta da/a (X) Door thickness from/to
60	22/28 mm
67	26/37 mm
80	38/48 mm
90	49/58 mm
100	59/68 mm

# X 0104

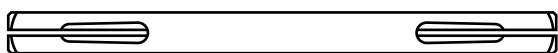

**Acciaio Zincato / Zinc Steel**

**Quadro tagliato**  7  
Slotted Spindle

<b>Lunghezza quadro</b> Spindle length	<b>(X) Spessore porta da/a</b> (X) Door thickness from/to
<b>114</b>	<b>34/42</b>

# X 0100/8

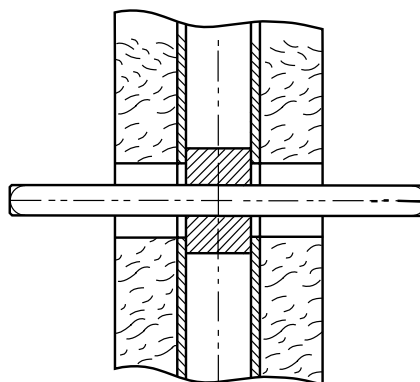
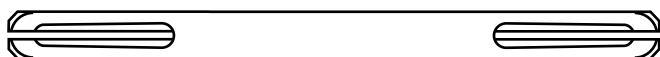

**Acciaio Zincato / Zinc Steel**

**Quadro tagliato**  8  
Slotted Spindle

<b>Lunghezza quadro</b> Spindle length	<b>(X) Spessore porta da/a</b> (X) Door thickness from/to
<b>80</b>	<b>fino a 20 mm / up to</b>
<b>114</b>	<b>32/48 mm</b>
<b>120</b>	<b>38/54 mm</b>
<b>130</b>	<b>48/64 mm</b>
<b>140</b>	<b>58/74 mm</b>
<b>145</b>	<b>63/79 mm</b>
<b>150</b>	<b>68/84 mm</b>
<b>160</b>	<b>78/94 mm</b>



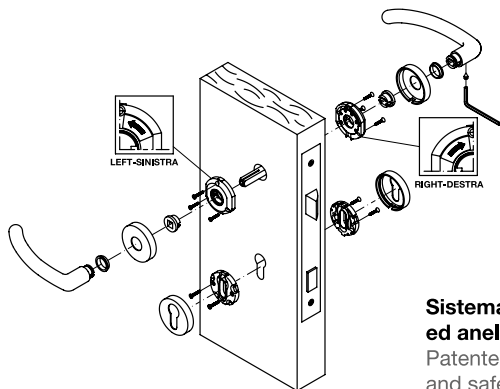

**Sistema di fissaggio brevettato con molla monodirezionale ed anello di sicurezza per maniglie con rosetta**

Patented mounting system with mono-directional spring and safety ring for handles on rosette

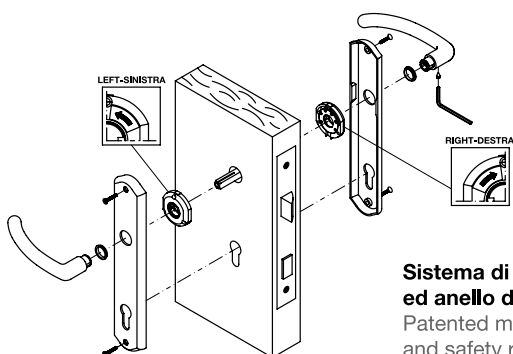

**Sistema di fissaggio brevettato con molla monodirezionale ed anello di sicurezza per maniglie su placca**

Patented mounting system with mono-directional spring and safety ring for handles on plate

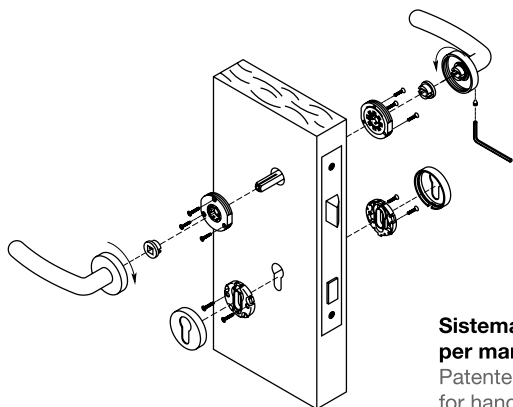

**Sistema di fissaggio brevettato con molla bidirezionale per maniglie con rosetta**

Patented mounting system with bi-directional spring for handles on rosette

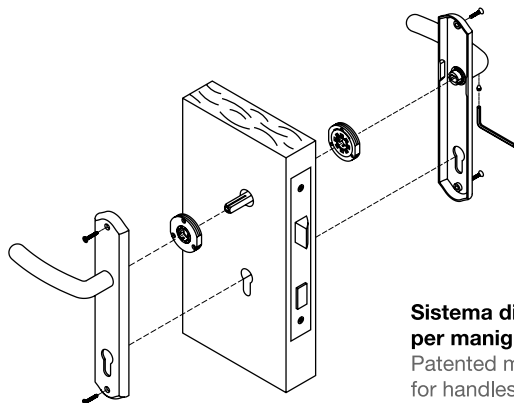

**Sistema di fissaggio brevettato con molla bidirezionale per maniglie su placca**

Patented mounting system with bi-directional spring for handles on plate

## Elenco Spessori per Porta per Articolo

### List of Door Thicknesses for Article

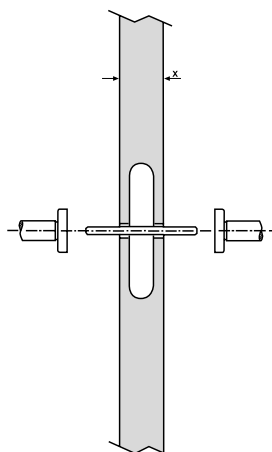

#### Maniglie per porta / Door handles

Articolo Article	Serie Series	Spessore da Thickness from	a to	con quadro with spindle
H 1048	Orione	33 mm	55 mm	8 x 114 mm
H 1047	Zaide	33 mm	55 mm	8 x 114 mm
H 1046	Nais	32 mm	63 mm	8 x 114 mm
H 1045	Bess	36 mm	62 mm	8 x 114 mm
H 1044	Oberon	40 mm	55 mm	8 x 104 mm
H 1043	Alcina	35 mm	64 mm	8 x 114 mm
H 1042	Walkiria	33 mm	62 mm	8 x 114 mm
H 1041	Porgy	37 mm	60 mm	8 x 114 mm
H 1040	Siberia	32 mm	59 mm	8 x 104 mm
H 1039	Fedra	27 mm	54 mm	8 x 104 mm
H 1038	Armida	35 mm	57 mm	8 x 114 mm
H 1037	Teseo	38 mm	50 mm	8 x 104 mm
H 1036	Amin	39 mm	50 mm	8 x 104 mm
H 123	Luigi XVI	39 mm	65 mm	8 x 114 mm
H 120	Luigi XV	42 mm	46 mm	8 x 80 mm
H 1034	Polis	35 mm	64 mm	8 x 114 mm
H 1032	Capriccio	30 mm	60 mm	8 x 114 mm
H 1030	Elisir	33 mm	55 mm	8 x 114 mm
H 1027	Dafne	33 mm	55 mm	8 x 114 mm
H 1026	Dido	33 mm	48 mm	8 x 96 mm
H 1024	Lolita	30 mm	55 mm	8 x 114 mm
H 1022	Ernani	37 mm	55 mm	8 x 114 mm
H 1018	Otello	33 mm	57 mm	8 x 114 mm
H 1017	Camelia	33 mm	57 mm	8 x 114 mm
H 1016	Nabucco	37 mm	57 mm	8 x 114 mm
H 1015	West	33 mm	55 mm	8 x 114 mm
H 1013	Mosè	42 mm	48 mm	8 x 96 mm
H 1012	Poliuto	33 mm	55 mm	8 x 114 mm
H 1010	Medea	33 mm	55 mm	8 x 114 mm
H 1004	Antares	37 mm	43 mm	8 x 96 mm
H 1003	Croco	33 mm	55 mm	8 x 114 mm
H 1000	Angelica	33 mm	43 mm	8 x 96 mm
H 914/8	Medicea	33 mm	55 mm	8 x 114 mm
H 227	Rigel	33 mm	55 mm	8 x 114 mm
H 198	Mizar	33 mm	55 mm	8 x 114 mm
H 196	Ulisse L	33 mm	55 mm	8 x 114 mm
H 195	Orchidea	33 mm	55 mm	8 x 114 mm
H 192	Prunus	33 mm	55 mm	8 x 114 mm
H 179	Aida	33 mm	55 mm	8 x 114 mm
H 176	Spiga	33 mm	55 mm	8 x 114 mm
H 174	Altair	33 mm	50 mm	8 x 114 mm
H 165	Germana	33 mm	53 mm	8 x 114 mm
H 163	Sarissa	33 mm	55 mm	8 x 114 mm





#### Pomoli per porta / Doorknobs

Articolo Article	Serie Series	Spessore da Thickness from	a to	con quadro with spindle
K 1165	Bess	42 mm	54 mm	8 x 114 mm
K 1160		37 mm	50 mm	8 x 104 mm
K 1155		33 mm	50 mm	8 x 114 mm
K 140	Germana	33 mm	53 mm	8 x 114 mm
K 121	Luigi XVI	33 mm	47 mm	8 x 96 mm
K 120	Luigi XV	31 mm	50 mm	8 x 96 mm

#### Maniglie per incasso / Inset handles

Articolo Article	Serie Series	Spessore da Thickness from	a to	con quadro with spindle
K 1230	Bess	34 mm	47 mm	6 x 40 mm
K 1211	Orfeide	34 mm	47 mm	6 x 37 mm
K 1204	Tancredi	36 mm	47 mm	6 x 40 mm
K 1200	Trittico	34 mm	47 mm	6 x 40 mm

#### Chiusure Privacy BZG / Bathroom Privacy Sets

Articolo Article	Serie Series	Spessore da Thickness from	a to	con quadro with spindle
K 1740		42 mm	52 mm	6 x 85 mm
K 1704		42 mm	52 mm	6 x 85 mm
K 1225		40 mm	46 mm	6 x 75 mm

Complementari e sistemi di fissaggio Acciaio Inox  
Complementary accessories and fixing systems Stainless Steel





# R8

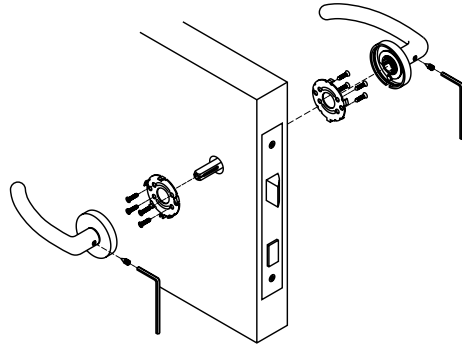

---

# R6 - R7 - R8 BZG

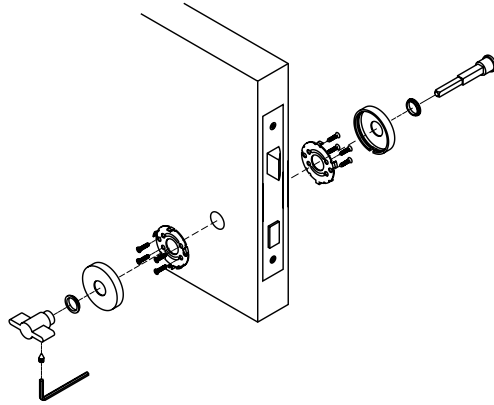

---

# RS6 - RS7 - RS8 BZG

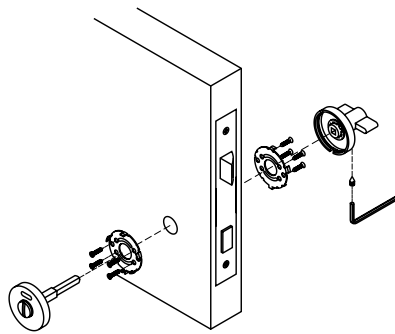

# X 0552

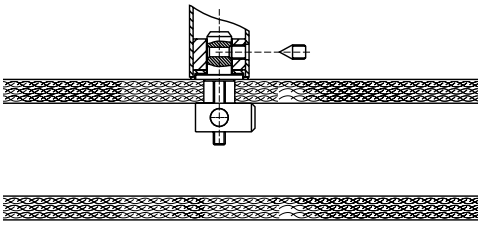

- 1 Grano M6 / M6 Grub Screw
- 2 Vite Speciale M8 / M8 Special Screw
- 4 Porta in Alluminio / Aluminium Door

**Per fissaggio singolo maniglione senza rosette coprivite su porta in alluminio**

For fixing a single pull handle without screw-covering rosettes on an aluminium door

P 2005 S 25 - P 2003 S (25/35) - P 2002 S (25/35) - P 2001 S (25/35)



# X 0510

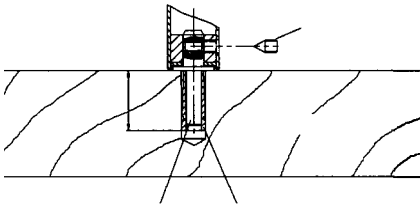

- 1 Grano M6 / M6 Grub Screw
- 2 Vite Speciale M8 / M8 Special Screw
- 3 Bussola ad Espansione in Ottone / Brass Anchor Screw
- 4 Porta in Legno / Wooden Door

**Per fissaggio singolo maniglione S su porta legno o parete in muratura con bussola ad espansione in ottone**

For fixing a single pull handle S on a wooden door or on a masonry wall using a brass anchor screw

# X 0509

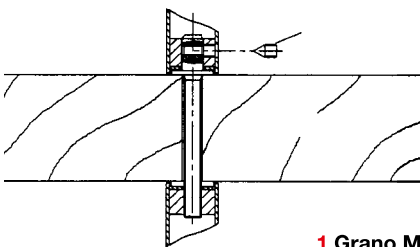

- 1 Grano M6 / M6 Grub Screw
- 2 Vite Speciale M8 / M8 Special Screw
- 3 Bussola ad Espansione in Ottone / Brass Anchor Screw
- 4 Porta in Legno / Wooden Door

**Per fissaggio coppia maniglioni su porta legno spessori:**

For fixing a pair of pull handles on a wooden door, thickness:

45-60 mm: X 0509-70

60-75 mm: X 0509-85

75-90 mm: X 0509-100



## X 0508

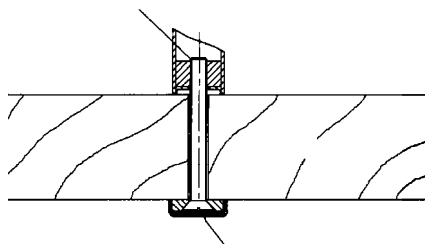

- 1 Vite M8 / M8 Screw
- 2 Porta in Legno / Wooden Door
- 3 Rosetta Coprivite / Screw Covering Rosette

**Per fissaggio singolo maniglione su porta legno spessori:**

For fixing a single pull handle on a wooden door, thickness:

45-60 mm: X 0508-75

60-75 mm: X 0508-90

75-90 mm: X 0508-105

## X 0507

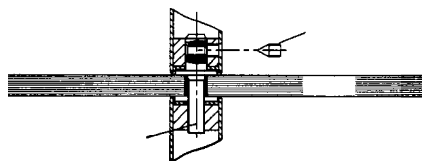

- 1 Grano M6 / M6 Grub Screw
- 2 Vite Speciale M8 / M8 Special Screw
- 3 Vetro / Glass

**Per fissaggio coppia maniglioni su porta vetro spessore 8-12 mm**

For fixing a pair of pull handles on a glass door, thickness 8-12 mm

**Foro consigliato ø 11 mm / Suggested hole ø 11 mm**

## X 0506

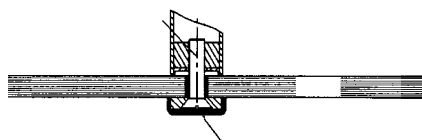

- 1 Vite M8 / M8 Screw
- 2 Rosetta Coprivite / Screw Covering Rosette
- 3 Vetro / Glass

**Per fissaggio singolo maniglione su porta vetro spessore 8-12 mm**

For fixing a pair of pull handles on a glass door, thickness 8-12 mm

**Foro consigliato ø 11 mm / Suggested hole ø 11 mm**

**Satinato / Satin**  
**Lucido / Polished**

# X 0602

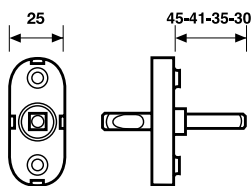

**Ferro** / Iron

**Movimento 4 scatti**  
4 click movement

**Zincato** / Zinc Plated



# X 0272



**Acciaio Inox** / Stainless Steel

**Viti a legno 4x15**  
Wood screw

# X 0203



**Acciaio Inox** / Stainless Steel

**Grano M6x6**  
Grub screw

# X 0202

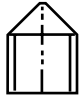

**Acciaio Inox** / Stainless Steel

**Grano M6x8**  
Grub screws

---

# X 0201

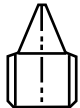

**Acciaio Inox** / Stainless Steel

**Grano M6x9**  
Grub screws

---



# X 0130/8

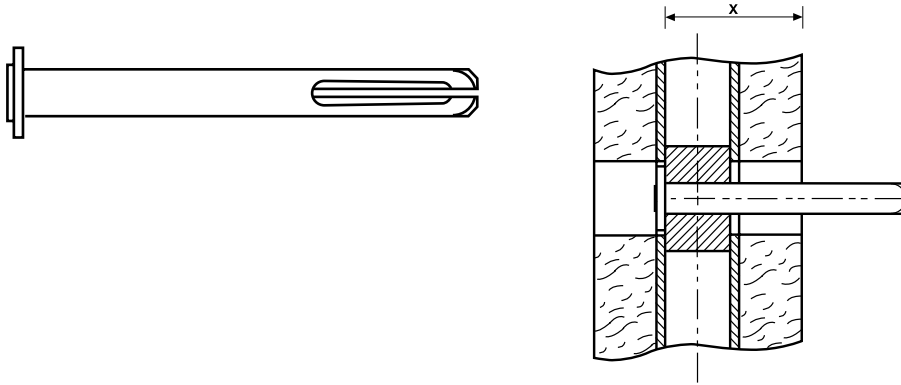

Acciaio Zincato / Zinc Steel

**Quadro block per porte forate passanti  $\square$  8**  
Block spindle for doors drilled from one side to the other

Lunghezza quadro Spindle length	(X) Spessore porta da/a (X) Door thickness from/to
60	20/29 mm
70	29/39 mm
75	35/43 mm
80	39/48 mm
85	45/53 mm
90	49/58 mm
100	59/68 mm
120	79/88 mm



# X 0120/8

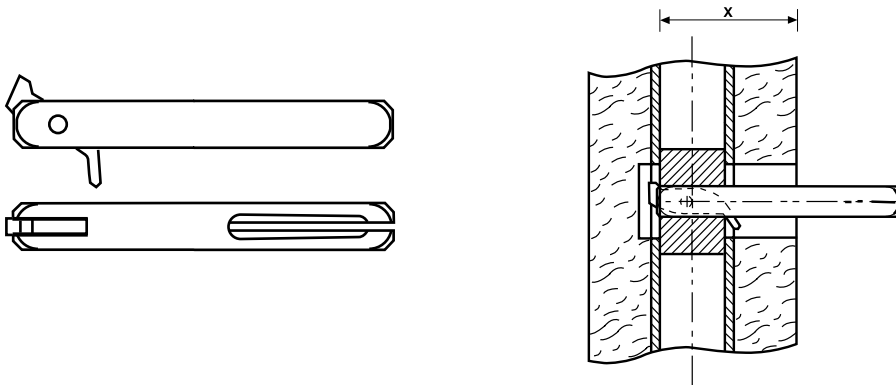

Acciaio Zincato / Zinc Steel

**Quadro block per porte forate solo da un lato  $\square$  8**  
Block spindle for doors drilled on one side only

Lunghezza quadro Spindle length	(X) Spessore porta da/a (X) Door thickness from/to
60	22/28 mm
67	26/37 mm
80	38/48 mm
90	49/58 mm
100	59/68 mm





# X 0110/8

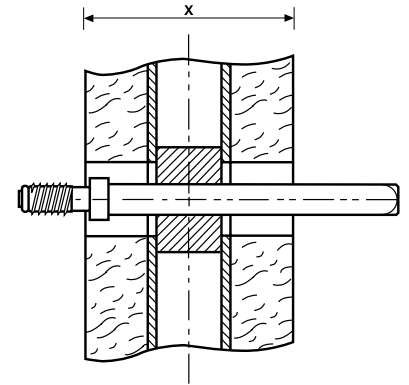
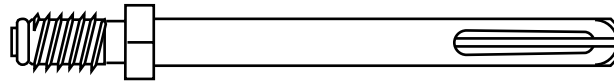

**Acciaio Zincato / Zinc Steel**

**Quadro con filetto per abbinamento maniglia-pomolo fisso**  8  
Threaded spindle for handle/fixe knob combination

Lunghezza quadro Spindle length	(X) Spessore porta da/a (X) Door thickness from/to
110	40/50 mm
110	50/60 mm
120	60/70 mm
130	70/80 mm
140	80/90 mm

# X 0100/8

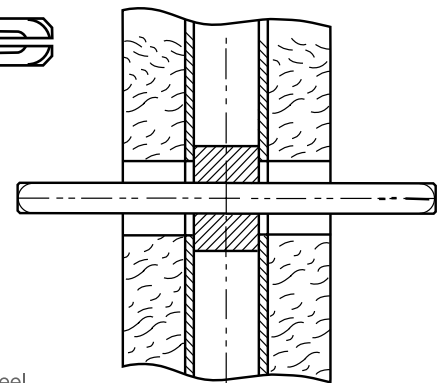
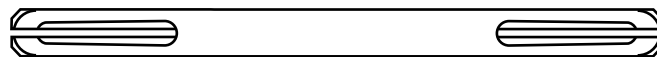

**Acciaio Zincato / Zinc Steel**

**Quadro tagliato**  8  
Slotted Spindle

Lunghezza quadro Spindle length	(X) Spessore porta da/a (X) Door thickness from/to
80	fino a 20 mm / up to
114	32/48 mm
120	38/54 mm
130	48/64 mm
140	58/74 mm
145	63/79 mm
150	68/84 mm
160	78/94 mm

# X 0130/9

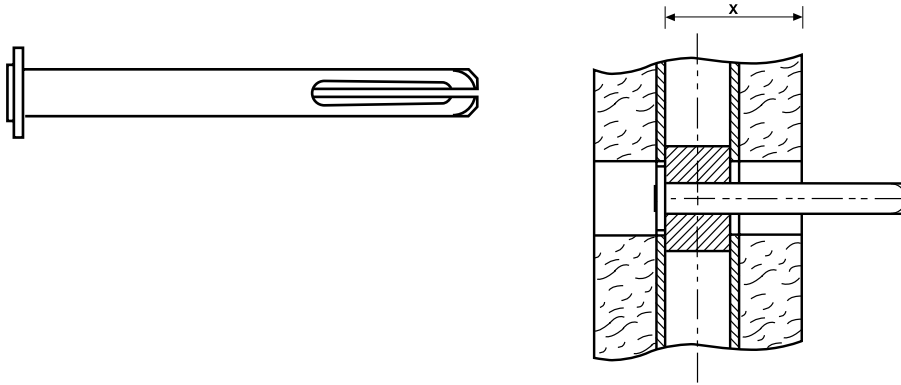

**Acciaio Zincato / Zinc Steel**

**Quadro block per porte forate passanti  $\square$  9**

Block spindle for doors drilled from one side to the other

Lunghezza quadro Spindle length	(X) Spessore porta da/a (X) Door thickness from/to
60	20/29 mm
70	29/38 mm
80	39/48 mm
90	49/58 mm

# X 0120/9

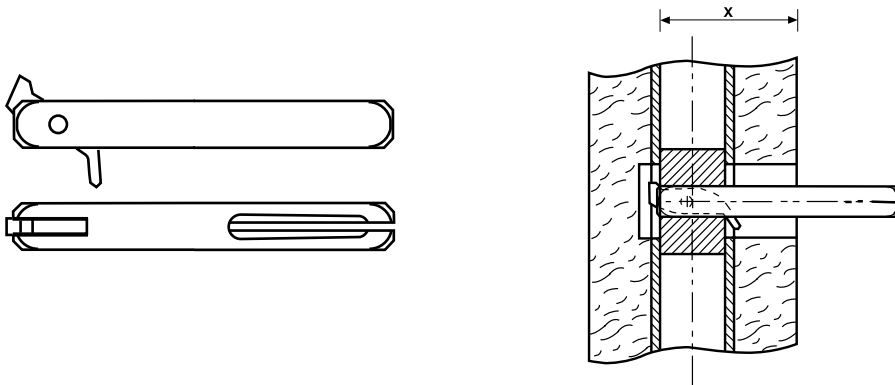

**Acciaio Zincato / Zinc Steel**

**Quadro block per porte forate solo da un lato  $\square$  9**

Block spindle for doors drilled on one side only

Lunghezza quadro Spindle length	(X) Spessore porta da/a (X) Door thickness from/to
60	22/28 mm
70	26/37 mm
80	38/48 mm
90	49/58 mm
100	59/68 mm



# X 0110/9

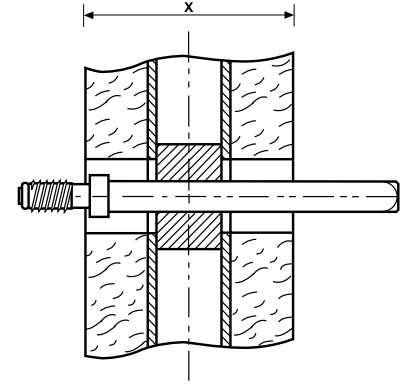
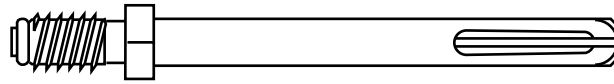

**Acciaio Zincato / Zinc Steel**

**Quadro con filetto per abbinamento maniglia-pomolo fisso**  9  
Threaded spindle for handle/fixed knob combination

Lunghezza quadro Spindle length	(X) Spessore porta da/a (X) Door thickness from/to
100	40/50 mm
110	50/60 mm
120	60/70 mm
130	70/80 mm
140	80/90 mm

# X 0100/9

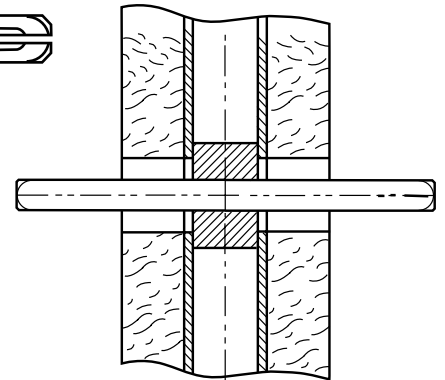
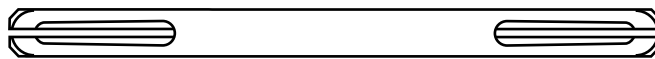

**Acciaio Zincato / Zinc Steel**

**Quadro tagliato**  9  
Slotted Spindle

Lunghezza quadro Spindle length	(X) Spessore porta da/a (X) Door thickness from/to
114	32/48 mm
120	38/54 mm
130	48/64 mm
140	58/74 mm
150	68/84 mm
160	78/94 mm

## Elenco Spessori per Porta per Articoli Acciaio Inox List of Door Thicknesses for Stainless Steel Articles

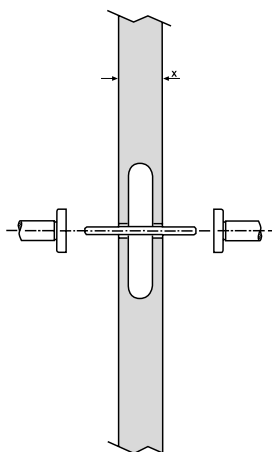

### Maniglie per porta / Door handles

Articolo Article	Serie Series	Spessore da Thickness from	a to	con quadro with spindle
H 2007 R8	Hekla	32 mm	44 mm	8 x 104 mm
H 2006 R8	Teide	34 mm	50 mm	8 x 114 mm
H 2005 R8	Kamet	34 mm	50 mm	8 x 114 mm
H 2004 R8	Illimani	36 mm	50 mm	8 x 114 mm
H 2003 R8	Pollino	34 mm	50 mm	8 x 114 mm
H 2002 R8	Logan	34 mm	50 mm	8 x 114 mm
H 2001 R8	Cevedale	34 mm	50 mm	8 x 114 mm

### Pomoli per porta / Doorknobs

Articolo Article	Serie Series	Spessore da Thickness from	a to	con quadro with spindle
K 2003		34 mm	50 mm	8 x 114 mm
K 2002		34 mm	50 mm	8 x 114 mm
K 2001		34 mm	50 mm	8 x 114 mm

### Chiusure Privacy BZG / Bathroom Privacy Sets

Articolo Article	Serie Series	Spessore da Thickness from	a to	con quadro with spindle
S 2001 R6-7-8 BZG		38 mm	44 mm	6 x 75 mm



Complementari e sistemi di fissaggio Accessori del Mobile  
Complementary accessories and fixing systems Cabinet Hardware





## X 0220

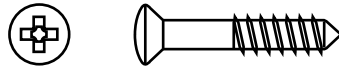

**Viti 2,2 x 14 TB TCOT**  
Screw

**Ottone** / Brass

**Fumé** / Iron

**Oro** / Brass

**Patiné** / Patiné

## X 0217

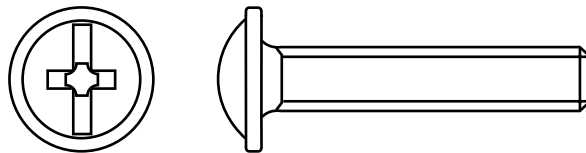

**Viti Testa Croce**  
Cross-Head Screw

**Ferro** / Iron

**Zincato** / Zinc plated

**Zincato** / Zinc plated

**Zincato** / Zinc plated

**Zincato** / Zinc plated

**Zincato** / Zinc plated

**Misura** / Size

M4 X 22 MM

M4 X 25 MM

M4 X 27 MM

M4 X 30 MM

M4 X 35 MM

## X 0216

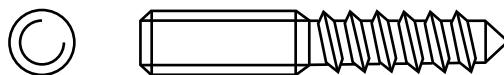

**Viti 4MA x 25**  
Screw

**Ferro** / Iron

**Zincato** / Zinc plated

# X 0211

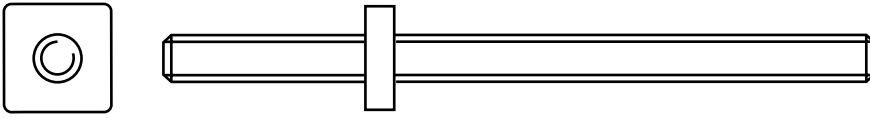

**Passante e Dado 4 MA x 60**  
Trough

**Ferro** / Iron

**Zincato** / Zinc plated







Avvertenze e Certificazioni  
Instructions and Certifications





## Avvertenze Instructions

Le maniglie per porta e i loro accessori hanno lo scopo di aprire e chiudere le porte e rappresentano un elemento complementare della porta, insieme al telaio della stessa, alla cerniera, al pannello, alla serratura e al cilindro. Aprire e chiudere una porta con una maniglia presuppone alcune azioni da compiere come ad esempio aprire l'eventuale catenaccio. Solo in casi particolari - come per porte con maniglie/maniglioni antipanico - queste azionano la funzione della serratura abbassando o spingendo la maniglia per porta.

Anche le maniglie per finestra rappresentano solo un elemento complementare della finestra. Normalmente il sistema di apertura della finestra determina la ferramenta utilizzata e quindi il meccanismo necessario alla maniglia da finestra per essere azionata.

Spesso le maniglie per porta, i maniglioni, le maniglie per finestra vengono utilizzate in modo non corretto, con conseguente danneggiamento del prodotto e dello standard di qualità definito dal Produttore.

Errori ricorrenti sono:

- utilizzo della maniglia quale appiglio o gancio per carichi anche pesanti;
- utilizzo della maniglia da parte dei bambini come strumento di gioco;
- utilizzo della maniglia o maniglione come fermaporta a muro;

I prodotti V&V Valli&Valli non richiedono eccessiva manutenzione; tuttavia per la cura e pulizia - ove non sia specificato l'utilizzo di prodotti particolari per trattamenti speciali - V&V Valli&Valli consiglia di utilizzare unicamente un panno asciutto. Per un corretto montaggio è necessario seguire le indicazioni contenute nelle singole confezioni oppure rivolgersi a Rivenditori o Personale specializzato. Per quanto riguarda i prodotti in vetro o porcellana, abbinati all'ottone, si ricorda che tali materiali sono fragili e soggetti a rotture se utilizzati in modo improprio; pertanto si consiglia, in prossimità delle porte e/o delle maniglie per porta, l'utilizzo di fermaporta a pavimento e/o a muro. V&V Valli&Valli consiglia sempre, su tutti i prodotti ove esiste un grano di fissaggio, l'applicazione di un frenafiletto. Si consiglia inoltre di verificare ad intervalli regolari la posizione e la stabilità di tutti gli elementi di fissaggio. L'utilizzatore/acquirente del prodotto è tenuto a richiedere al Rivenditore istruzioni circa il corretto montaggio, la cura e manutenzione del prodotto.

I prodotti V&V Valli&Valli vengono continuamente sviluppati, la produzione costantemente sorvegliata dall'Assicurazione Qualità Valli&Valli.

La maggior parte dei prodotti V&V Valli&Valli è composta da "strumenti di lavoro" per aprire e chiudere porte e finestre: inevitabilmente, come ogni oggetto, a seconda del materiale scelto e del luogo di utilizzo, anche i nostri prodotti sono soggetti alle leggi del tempo e dell'usura.

L'ottone, lega di metalli soggetta al processo di ossidazione, deve essere rivestito da uno strato protettivo affinché le sue qualità rimangano inalterate nel tempo: pertanto è necessario avere cura nell'utilizzo e manutenzione dei prodotti poiché un uso improprio e/o inadeguata manutenzione andrebbero ad intaccare lo strato protettivo e a generare quindi effetti corrosivi con conseguenze antiestetiche.

Il materiale acciaio inox, notoriamente, è sinonimo di indistruttibilità. Tuttavia, anche sull'acciaio inox possono comparire graffi e macchie di ruggine occasionali; per queste ultime si tratta della cosiddetta "ruggine superficiale" che può essere rimossa con adeguati detergenti, rivolgendosi presso Rivenditori specializzati. Non si risponde per danni conseguenti alla normale usura, al trattamento, montaggio e manutenzione inappropriati, e all'inosservanza delle avvertenze di cui sopra.

Door handles and their accessories are designed to open and close doors. They represent a complementary element of the door, together with the frame, hinges, door panel, lock and cylinder. Opening and closing a door with a handle requires certain actions, such as opening a security bolt. Only in certain cases, such as on emergency doors, the handle serves the function of working the lock by lowering or pushing it.

Window handles too are to be considered only a complementary part of the window. It is normally the opening system of the window that determines the hardware required and consequently the mechanism required for the working of the window handle.

Door handles, pull handles and window handles are often incorrectly used, damaging the product and the quality standard defined by the producer.

Common errors include:

- The use of the handle as a support or hook for objects which may be excessively heavy.
- The use of the handle as a plaything by children.
- The use of the handle as a doorstop against the wall.

V&V Valli&Valli products do not require excessive maintenance.

For care and cleaning, except in those cases where a specific product is recommended for certain finishes, V&V Valli&Valli recommends the use of just a soft dry cloth.

To ensure correct fixing, the instructions contained in the box should be followed.

If necessary consult the retailer or specialised personnel.

In the case of products in glass or porcelain together with brass, it should be remembered that these fragile materials are liable to break if used incorrectly. Fusital recommends the use of doorstops fixed to the floor or the wall close to the door or its handle.

On all products with a grub screw V&V Valli&Valli recommends the use of a retaining compound. It is also advisable to check the position and tightness of all fixing elements at regular intervals. The user/purchaser of the product should ask the retailer for instructions regarding the correct fixing, care and maintenance of the product.

V&V Valli&Valli products are subject to a continual process of development and updating, and production is constantly monitored by Valli&Valli Quality Assurance.

Most V&V Valli&Valli products are “tools” for opening and closing doors and windows. Inevitably, as with all artifacts, depending on the material of which they are made and where they are used, they are subject to wear and the passing of time.

Brass, an alloy subject to oxidation, has to be covered with a protective coating if its appearance is to remain unchanged over time. Care should be taken during use and maintenance, as improper use or poor maintenance could damage the protective coating, permitting corrosion and consequently causing an anti-aesthetic appearance.

Stainless steel is generally considered to be indestructible.

However, even this material can show the occasional scratch or spot of rust.

Such rust-spots are so-called “surface rust”, and can be removed using an appropriate cleaner, available from specialised retailers.

The manufacturer cannot be held responsible for damage due to normal wear and tear, incorrect treatment, fixing or maintenance or to non-observance of the above warnings.



## Qualità UNI EN ISO 9001:2000 Quality



Valli&Valli srl, dal dicembre 1996, ha ottenuto la certificazione del proprio sistema di qualità secondo le normative UNI EN ISO 9001:1994, aggiornate il 28-11-2003 secondo nuova normativa UNI EN ISO 9001:2000.

La Valli&Valli ha adeguato il sistema di gestione della Qualità Aziendale alla normativa UNI EN ISO 9001:2000, norma che permette di verificare il proprio standard qualitativo durante tutte le fasi produttive e di monitorare la qualità del servizio offerto in funzione delle specifiche esigenze della Clientela. L'Istituto ICILA, operante e sempre più presente nel settore del legno e dell'arredamento, ha rilasciato la certificazione nel dicembre 1996.



Per raggiungere questo importante traguardo è stata posta la massima attenzione ai seguenti processi aziendali, che sono aree in costante miglioramento:

- La progettazione: ogni prodotto è studiato per essere più aderente alle esigenze estetiche e funzionali del consumatore. Severamente testato e collaudato per ricercare soluzioni al fine di renderlo sempre più affidabile.
- La gestione degli ordini: ponendo la massima attenzione ad ogni richiesta del cliente.
- Il processo produttivo: con particolare attenzione al miglioramento delle tecnologie e delle risorse impiegate ed alla pianificazione ed attuazione dei controlli qualitativi durante le fasi di produzione.
- La selezione dei fornitori e dei partner: instaurando con i più accreditati un rapporto di collaborazione e di crescita reciproca.
- L'analisi dei dati del Sistema Qualità: dalla non conformità dei prodotti a qualsiasi altra informazione che possa indurre un processo di miglioramento.
- La formazione e l'addestramento della risorsa umana: instaurando ad ogni livello la consapevolezza della propria centralità nell'ottenimento di una più elevata qualità.

Il raggiungimento di questo ambito obiettivo è stato ottenuto grazie alle energie di tutto il nostro personale, a cui va un doveroso ringraziamento per la decisione e la volontà dimostrata nell'intraprendere la strada del miglioramento.



ICILA

ISO 9001:2000  
Cert./ Zertificat n. 77

Istituto per la Certificazione  
di Qualità delle Industrie del  
Legno e dell'Arredamento

Institute for the Certification  
of Quality in the Wood and  
Decorative Industries

Valli&Valli srl has had its Company Quality System certified in accordance with UNI EN ISO 9001:1994 norms since December 1996, up-dated on November 28th 2003 in compliance with the new norms UNI EN ISO 9001:2000

Valli&Valli has now brought its Company Quality System in line with UNI EN ISO 9001:2000 norms, which permit the examination of our quality standards during all manufacturing phases, and the monitoring of the quality of service offered in response to the specific requirements of the Customers.

The ICILA Institute, which is increasingly active in the wood and furniture sector, issued the certification in December 1996.



Certificazione Italiana dei  
Sistemi di Qualità

Italian Certification of Quality  
Systems

In order to achieve this important goal the company has devoted its utmost attention to the following processes, which are areas subject to continual improvement:

- Development: each product is studied to best comply with the aesthetical and functional requirement of the final consumer. Rigorous tests are carried out searching always for new solutions for more reliable products.
- Order management: always giving the utmost attention to any request from Customers.



ISO 9001:2000  
Cert./ Zertificat n. IT-2528

International Quality Network

- Manufacturing process: with particular attention to technology and resources improvement as well as to planning and carrying out of quality control during the different manufacturing phases.
- Selection of Suppliers and Partners: by establishing with the most qualified suppliers a cooperation aimed at a common growth.
- Analysis of Quality System data: starting from product non-conformity and including any other possible information which can lead to improved processes.
- Education and training of human resources: by creating at all levels an awareness of each individual's importance in achieving a general higher quality.

The achievement of this important goal was made possible thanks to the efforts of the entire staff, to whom go our sincere thanks for the decisiveness and willingness shown in pursuing this road to improvement.



## Trattamento Protettivo ad Alta Resistenza High Grade Protective Coating



### Attestato di qualità

Si attesta che il trattamento della superficie effettuato ai nostri prodotti, denominato Zirtanio è garantito 30 anni\*.

Tale trattamento ha superato i seguenti test:

- Resistenza alla nebbia salina (1500 ore) secondo le norme ISO 9227 ASTMB117 DIN 50021
- Resistenza ai solventi secondo test MFK
- Resistenza ai prodotti specifici anticalcare
- Resistenza all'acido muriatico illimitata
- Resistenza di solidità alla luce senza alterazione secondo le norme UNI 9397

Per la pulizia consigliamo l'utilizzo di un panno inumidito con alcool.

\*Si declina ogni responsabilità per un utilizzo negligente od improprio dei prodotti.



La maniglia ed i suoi coordinati, ormai divenuti veri complementi d'arredo, sono comunque oggetti di uso quotidiano e quindi, inevitabilmente, soggetti ad una naturale usura. Inoltre, particolari situazioni climatiche, agenti atmosferici come salsedine e umidità o l'utilizzo in situazioni gravose, possono accelerare questi processi, intaccando lo strato protettivo e generando effetti corrosivi con conseguenze antiestetiche.

Grazie al trattamento Zirtanio, che viene effettuato sulla superficie dei prodotti, Valli&Valli garantisce la protezione per 30 anni.

Trattandosi di una finitura a richiesta gli uffici commerciali restano a completa disposizione per ogni ulteriore informazione e chiarimento.

### Quality Certificate

We certify that the treatment applied as a coating to the surface of our products and known as ZIRTANIO is guaranteed for 30 years\*.

This treatment has passed the following tests:

- Resistance to salt spray (1500 hours) conforming to standard ISO 9227 ASTMB117 DIN 50021
- Resistance to solvents conforming to standard MFK
- Resistance to specific anti-calcareous products
- Unlimited resistance to muriatic acid
- Resistance to alteration caused by strong light conforming to standard UNI 9397

For cleaning we advise using a cloth dampened with alcohol.

\* We disclaim all responsibility if there is negligent or inappropriate use of products.

The door handle and its accessories, which have become part of the furnishing of the home, are subject to daily use, and consequently to natural wear and tear. In addition, certain climatic conditions, or atmospheric agents such as salt-air or high humidity, or use in detrimental conditions can accelerate the ageing process, damaging the protective coating and causing corrosion with un-aesthetic results.

Thanks to the Zirtanio treatment, applied to the surface of the products, Valli&Valli guarantees protection for 30 years.

This finish is applied on request. For any further information or explanation you may require, please feel free to contact our offices.

Prodotti con trattamento protettivo ad alta resistenza  
High grade protective coating products



<b>H 1040 R8 / R8 Y</b>	<b>Serie SIBERIA / design Gabriele e Oscar Battuti</b> <b>Maniglia per porta / Door handle</b>
<b>H 1040 F</b>	<b>Serie SIBERIA / design Gabriele e Oscar Battuti</b> <b>Maniglia per finestra / Window handle</b>
<b>H 1040 F RS-41</b>	<b>Serie SIBERIA / design Gabriele e Oscar Battuti</b> <b>Maniglia per finestra / Window handle</b>
<b>H 1034 R8 / R8 Y</b>	<b>Serie POLIS / design Decoma Design</b> <b>Maniglia per porta / Door handle</b>
<b>H 1034 F</b>	<b>Serie POLIS / design Decoma Design</b> <b>Maniglia per finestra / Window handle</b>
<b>H 1034 FR S</b>	<b>Serie POLIS / design Decoma Design</b> <b>Maniglia per finestra / Window handle</b>
<b>K 1131 / K 1131 Y</b>	<b>Bocchetta / Escutcheon</b>
<b>H 195 R8 / R8 Y</b>	<b>Serie ORCHIDEA / design StudioValli</b> <b>Maniglia per porta / Door handle</b>
<b>H 195 F</b>	<b>Serie ORCHIDEA / design Valli Workshop</b> <b>Maniglia per finestra / Window handle</b>
<b>H 195 FR S</b>	<b>Serie ORCHIDEA / design Valli Workshop</b> <b>Maniglia per finestra / Window handle</b>
<b>K 1138 / K 1138 Y</b>	<b>Bocchetta / Escutcheon</b>
<b>K 1119 / K 1119 Y</b>	<b>Bocchetta / Escutcheon</b>
<b>K 1162</b>	<b>Pomolo per porta / Door knob</b>
<b>K 1155</b>	<b>Pomolo per porta / Door knob</b>
<b>K 1153</b>	<b>Pomolo per porta / Door knob</b>
<b>K 1227</b>	<b>Serie SIBERIA / design Gabriele e Oscar Battuti</b> <b>Maniglione / Pull handle</b>
<b>K 1216</b>	<b>Serie DAFNE / design Studio Carlesi Design</b> <b>Maniglione / Pull handle</b>
<b>K 1210</b>	<b>Serie MIZAR / design Eero Aarnio</b> <b>Maniglione / Pull handle</b>
<b>K 1207</b>	<b>Maniglione / Pull handle</b>
<b>K 1188</b>	<b>Maniglione / Pull handle</b>
<b>K 1704 R</b>	<b>Chiusura privacy BZG / Bathroom privacy set</b>
<b>K 1704 RS</b>	<b>Chiusura privacy BZG / Bathroom privacy set</b>
<b>K 1135</b>	<b>Bocchetta / Escutcheon</b>
<b>K 1135 RS</b>	<b>Rosetta / Rosette</b>
<b>L 18</b>	<b>Battiporta / Door knocker</b>
<b>L 17</b>	<b>Battiporta / Door knocker</b>



**Valli&Valli srl**

20055 Renate (Mi) Italy  
Via Concordia, 16  
Tel. +39 0362.982.1

**Ufficio Commerciale Italia  
Italian Commercial Office**

Tel. +39 0362.982271  
Fax +39 0362.999035  
vendite.italia@vallievalli.com

**Ufficio Commerciale Export  
Export Business Office**

Tel. +39 0362.982260  
Fax +39 0362.924455  
export@vallievalli.com

**Show-room New York**

964 Third Ave, Suite 563 / Annex  
New York, NY 10155  
Tel. +1 (212) 326 8811  
Fax +1 (212) 326 8816

**[www.vallievalli.com](http://www.vallievalli.com)**  
**[www.assaabloy.it](http://www.assaabloy.it)**

**Co-ordination**

Valli&Valli - Renate (MI)

**Graphic Design**

Hangar Design Group  
[www.hangar.it](http://www.hangar.it)

**Products's photos**

Ontime - Borgomanero

**Technical drawings**

Valli&Valli - Renate (MI)  
C&V srl - Lissone (MI)

**Color Separation**

Photo Litho Type Abc - Milano

**Printing**

Grafiche Marini - Villorba (TV)

**La Valli&Valli si riserva il diritto di apportare eventuali modifiche atte a migliorare i prodotti, senza alcun preavviso. Le misure dei nostri prodotti indicate nel presente catalogo si intendono approssimative.**

La Valli&Valli reserve the right to make eventual modifications directed towards improving their products, without previous notice. The sizes of our products indicated in this catalogue are indicative.



ASSA ABLOY is the global leader in door opening solutions, dedicated to satisfying end-user needs for security, safety and convenience.

RIF. **Z1270** 04/09