

CLIP SLIM: MANIGLIE AD INCASSO A SPESSORE RIDOTTO PER PORTE SCORREVOLI FLUSH-HANDLES FOR SLIDING THIN DOORS

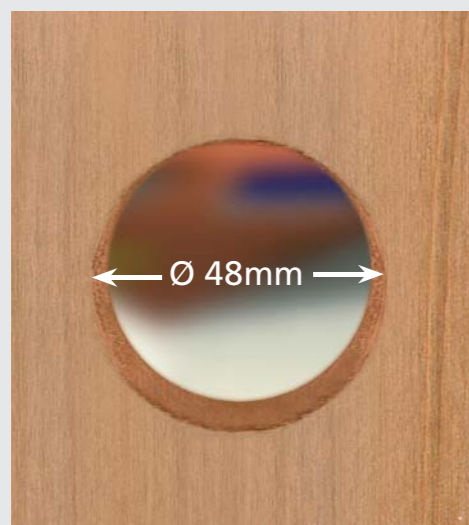

Clip Slim

Clip Slim nasce per risolvere i problemi di ingombro delle porte scorrevoli all'interno di cassoni predisposti per il rivestimento a cartongesso o di cassoni con spessori ridotti rispetto a quelli standard. Clip Slim utilizza il foro standard Ø 48 mm.

Clip Slim is born to solve the problems of encumbrance of sliding doors placed inside of cabinets-carcase arranged for plaster-board's covering or cabinets-carcase, with reduced thicknesses compared with the standard ones. Clip Slim for standard hole 48 mm diameter.

1048T



Kit maniglia per porta scorrevole, spessore porta minimo 20 mm, sporgenza cover 3 mm.

Flush-handle kit for sliding doors, minimum door thickness 20 mm, cover thickness 3 mm.

1048TN



Kit maniglia per porta scorrevole con nottolino q.6 senza serratura. Sporgenza cover 3 mm.

Flush-handle kit for sliding doors with indicator q.6, no lock. Cover thickness 3 mm.

1048TN/S



Kit maniglia per porta scorrevole con nottolino q.6 completa di serratura. Spessore porta minimo 35+50 mm, sporgenza cover 3 mm.

Flush-handle kit for sliding doors with lock and indicator q.6. Minimum door thickness 35+50 mm, cover thickness 3 mm.

1048TNN/S



Kit maniglia per porta scorrevole con nottolini q.6 completa di serratura. Spessore porta minimo 35+50 mm, sporgenza cover 3 mm.

Flush-handle kit for sliding doors with lock and indicator q.6. Minimum door thickness 35+50 mm, cover thickness 3 mm.



1048T

ClipSlim

ClipSlim 1048T

1048T

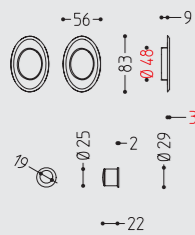

1048TN

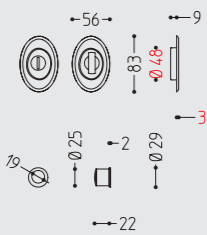

1048TN/S

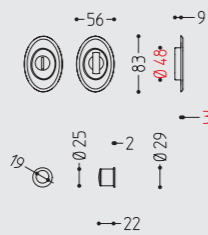

1048TNN

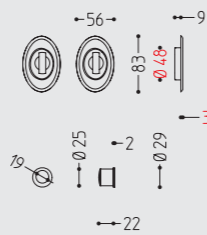

1048TNN/S

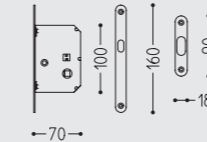
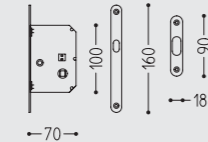
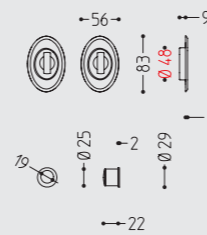

Maniglia per porta scorrevole_Flush-handle for sliding door

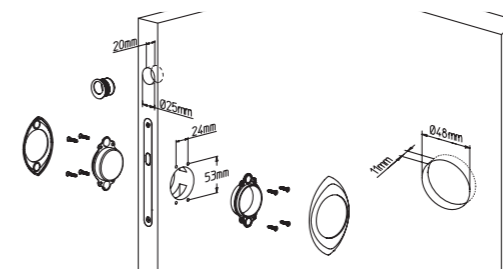

Finiture_Finishes

Materiale: **ottone pressofuso**
Material: **die cast brass**



03L



04T



26DT



MBR



MSN



MTC

1058T

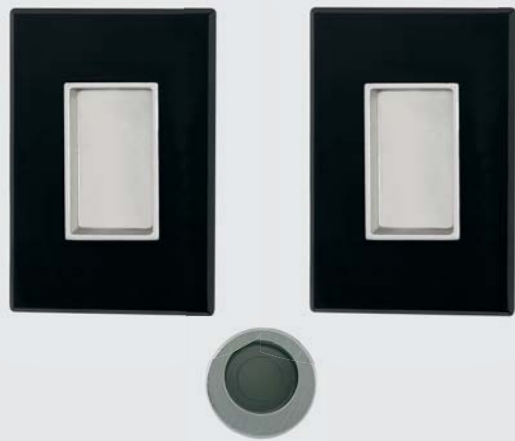

Kit maniglia per porta scorrevole, spessore porta minimo 20 mm, sporgenza cover 3 mm.

Flush-handle kit for sliding doors, minimum door thickness 20 mm, cover thickness 3 mm.



1058T

ClipSlim

ClipSlim 1058T

1058T

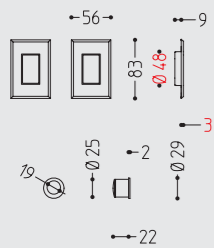

Finiture_Finishes

Materiale: **ottone pressofuso**
Material: **die cast brass**



Maniglia per porta scorrevole_Flush-handle for sliding door

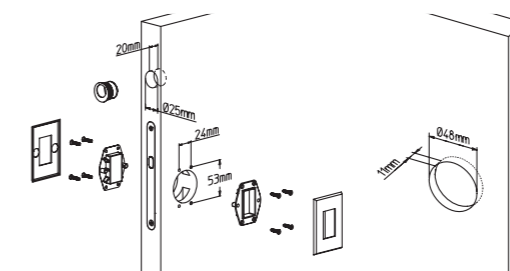

1068T



Kit maniglia per porta scorrevole, spessore porta minimo 20 mm, sporgenza cover 3 mm.

Flush-handle kit for sliding doors, minimum door thickness 20 mm, cover thickness 3 mm.

1068TN

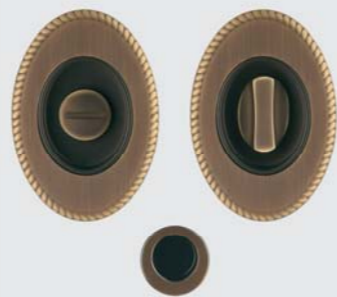

Kit maniglia per porta scorrevole con nottolino q.6 senza serratura. Sporgenza cover 3 mm.

Flush-handle kit for sliding doors with indicator q.6, no lock. Cover thickness 3 mm.

1068TN/S



Kit maniglia per porta scorrevole con nottolino q.6 completa di serratura. Spessore porta minimo 35+50 mm, sporgenza cover 3 mm.

Flush-handle kit for sliding doors with lock and indicator q.6. Minimum door thickness 35+50 mm, cover thickness 3 mm.

1068TNN/S



Kit maniglia per porta scorrevole con nottolini q.6 completa di serratura. Spessore porta minimo 35+50 mm, sporgenza cover 3 mm.

Flush-handle kit for sliding doors with lock and indicator q.6. Minimum door thickness 35+50 mm, cover thickness 3 mm.



1068T

ClipSlim

ClipSlim 1068T

1068T

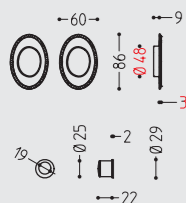

1068TN

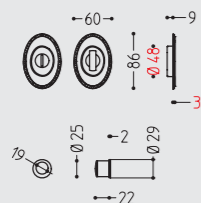

1068TN/S

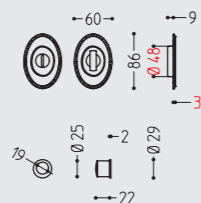

1068TNN

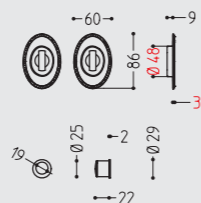

1068TNN/S

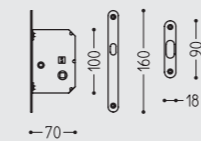
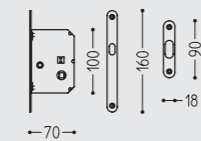
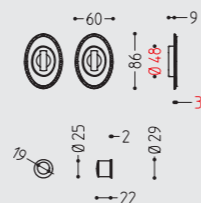

Finiture_Finishes

Materiale: **ottone pressofuso**
Material: **die cast brass**



04T



28*



MBR

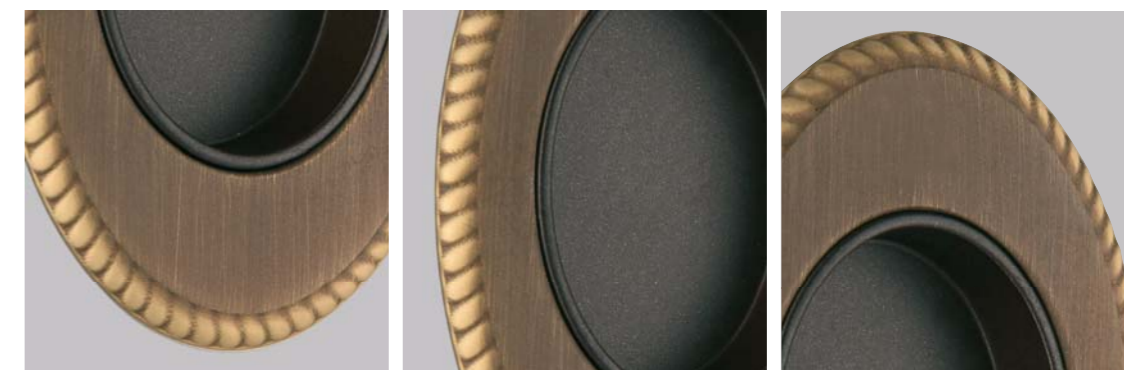

Maniglia per porta scorrevole_Flush-handle for sliding door

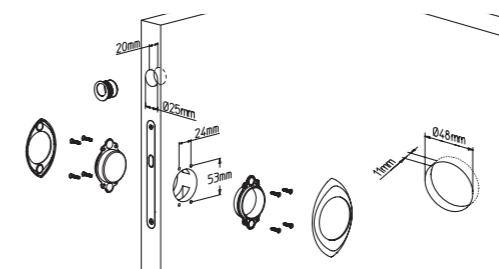

* La finitura 28 è ottenuta con processi naturali, che come tali non consentono l'uniformità di colore e di tonalità fra i singoli pezzi.

The 28 finish is obtained with natural elements that do not allow colour consistency from piece to piece.

CLIP MANIGLIA AD INCASSO PER PORTE SCORREVOLI FLUSH-HANDLES FOR SLIDING DOORS

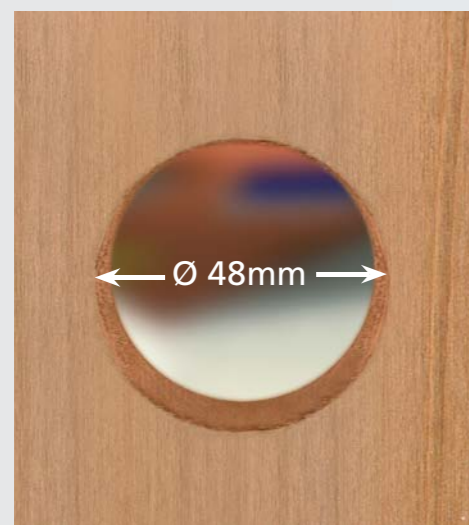

Clip

Basta un semplice "CLIP" per fissare la cover.
Non richiede siliconi o complicati sistemi di fissaggio.
Quattro viti, un "CLIP" e.... la maniglia
per lo scorrevole è pronta, perfettamente
integrata con la vostra porta.
"CLIP" è la prima maniglia con il montaggio semplice,
rapido e pulito brevettato dalla Mandelli & C. S.p.A.

Just a click and "CLIP" is on.
No silicone, no hard assembling is needed.
Four screws, one click....and "CLIP"
is immediately part of your door.
"CLIP" is the first flush-handle of easy,
quick and clean assembling.
"CLIP" is patented by Mandelli & C. S.p.A.

368TC/S



Kit maniglia per porta scorrevole con foro chiave completa di chiave a snodo e serratura. Spessore porta 35+50 mm.

Flush-handle kit for sliding doors with standard key-hole, foldable key and lock. Door thickness 35+50 mm.

368TN/S



Kit maniglia per porta scorrevole con nottolino q.6 completa di serratura. Spessore porta 35+50 mm.

Flush-handle kit for sliding doors with lock and indicator q.6. Door thickness 35+50 mm.

368TL

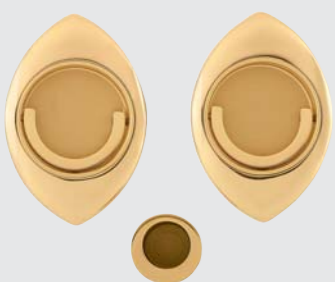

Kit maniglia per porta a libro, spessore porta minimo 20 mm.

Handle kit for folding doors, minimum door thickness 20 mm.

368TLN



Kit maniglia per porta a libro con nottolino q.6 senza serratura.

Handle kit for folding doors with indicator q.6, no lock.



368T

Clip

Clip 368T

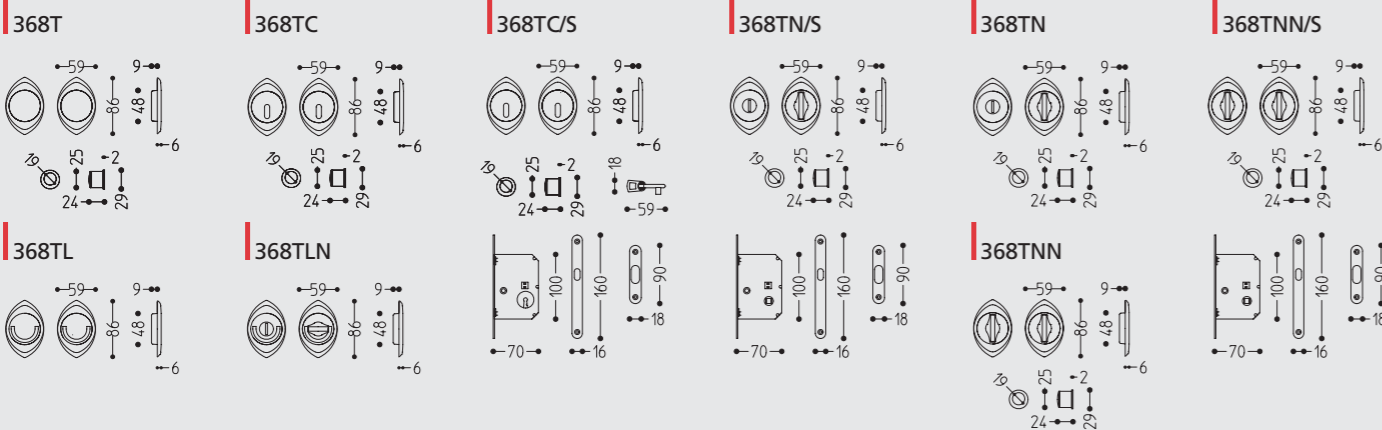

Maniglia per porta scorrevole_Flush-handle for sliding door

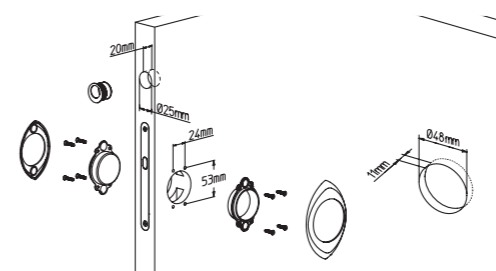

Finiture_Finishes

Materiale: **ottone pressofuso**
Material: **die cast brass**

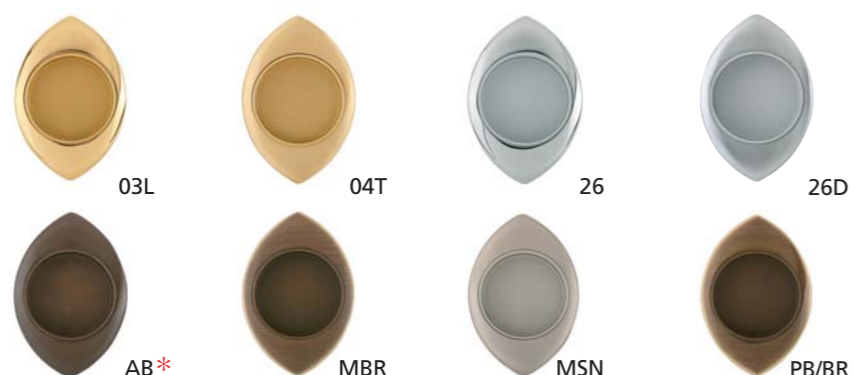

* La finitura AB è ottenuta con processi naturali, che come tali non consentono l'uniformità di colore e di tonalità fra i singoli pezzi.

The AB finish is obtained with natural elements that do not allow colour consistence from piece to piece.

Clip È un brevetto Mandelli & C. spa
Is a registered patent by Mandelli & C. spa

1018TC/S



Kit maniglia per porta scorrevole con foro chiave completa di chiave a snodo e serratura. Spessore porta 35+50 mm.

Flush-handle kit for sliding doors with standard key-hole, foldable key and lock. Door thickness 35+50 mm.

1018TN/S



Kit maniglia per porta scorrevole con nottolino q.6 completa di serratura. Spessore porta 35+50 mm.

Flush-handle kit for sliding doors with lock and indicator q.6. Door thickness 35+50 mm.

1018TL



Kit maniglia per porta a libro, spessore porta minimo 20 mm.

Handle kit for folding doors, minimum door thickness 20 mm.

1018TLN

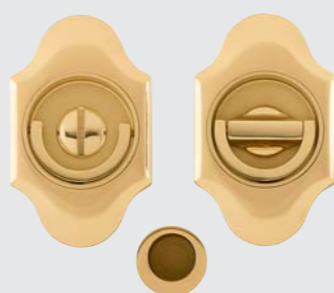

Kit maniglia per porta a libro con nottolino q.6 senza serratura.

Handle kit for folding doors with indicator q.6, no lock.



1018T

Clip

Clip 1018T

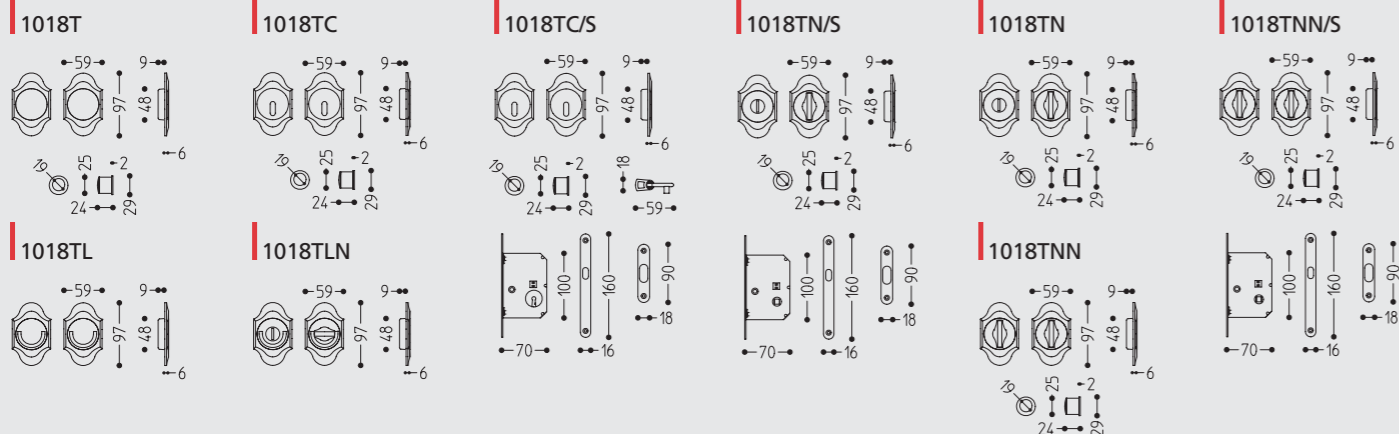

Finiture_Finishes

Materiale: **ottone pressofuso**
Material: **die cast brass**

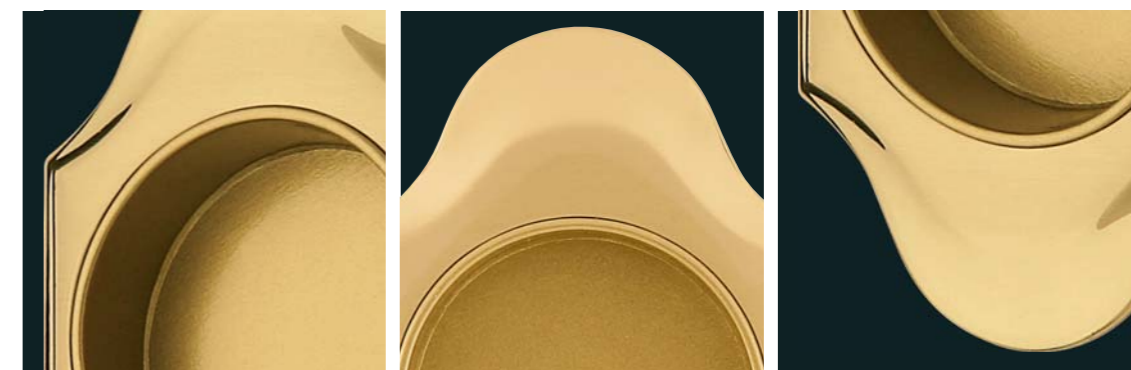

Maniglia per porta scorrevole_Flush-handle for sliding door

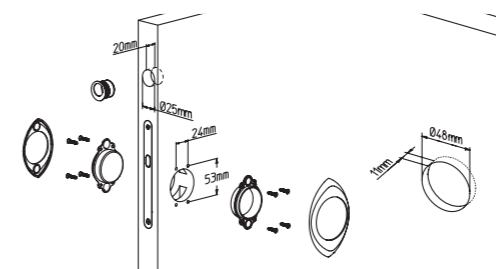

* La finitura AB è ottenuta con processi naturali, che come tali non consentono l'uniformità di colore e di tonalità fra i singoli pezzi.

The AB finish is obtained with natural elements that do not allow colour consistence from piece to piece.

1028TC/S



Kit maniglia per porta scorrevole con foro chiave completa di chiave a snodo e serratura. Spessore porta 35+50 mm.

Flush-handle kit for sliding doors with standard key-hole, foldable key and lock. Door thickness 35+50 mm.

1028TN/S



Kit maniglia per porta scorrevole con nottolino q.6 completa di serratura. Spessore porta 35+50 mm.

Flush-handle kit for sliding doors with lock and indicator q.6. Door thickness 35+50 mm.

1028TL



Kit maniglia per porta a libro, spessore porta minimo 20 mm.

Handle kit for folding doors, minimum door thickness 20 mm.

1028TLN



Kit maniglia per porta a libro con nottolino q.6 senza serratura.

Handle kit for folding doors with indicator q.6, no lock.



1028T

Clip

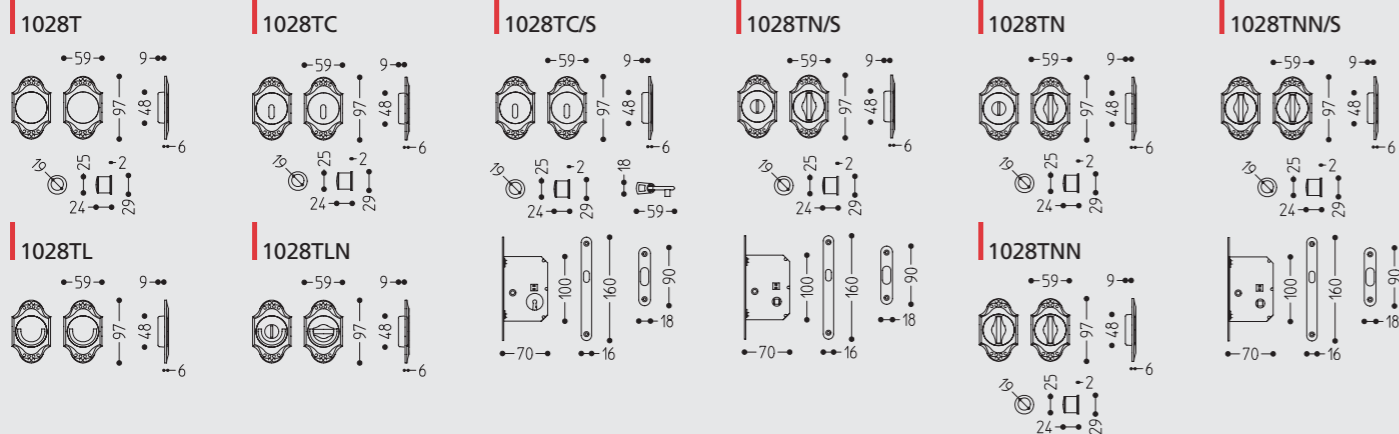

Finiture_Finishes

Materiale: **ottone pressofuso**
Material: **die cast brass**



Maniglia per porta scorrevole_Flush-handle for sliding door

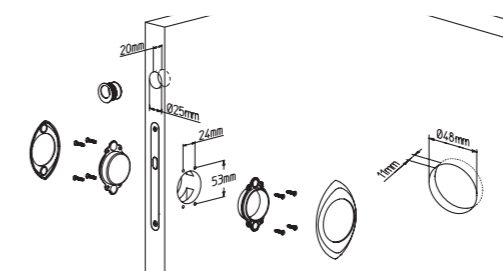

* La finitura AB è ottenuta con processi naturali, che come tali non consentono l'uniformità di colore e di tonalità fra i singoli pezzi.

The AB finish is obtained with natural elements that do not allow colour consistence from piece to piece.

1038TC/S



Kit maniglia per porta scorrevole con foro chiave completa di chiave a snodo e serratura. Spessore porta 35+50 mm.

Flush-handle kit for sliding doors with standard key-hole, foldable key and lock. Door thickness 35+50 mm.

1038TN/S



Kit maniglia per porta scorrevole con nottolino q.6 completa di serratura. Spessore porta 35+50 mm.

Flush-handle kit for sliding doors with lock and indicator q.6. Door thickness 35+50 mm.

1038TL



Kit maniglia per porta a libro, spessore porta minimo 20 mm.

Handle kit for folding doors, minimum door thickness 20 mm.

1038TLN



Kit maniglia per porta a libro con nottolino q.6 senza serratura.

Handle kit for folding doors with indicator q.6, no lock.



1038T

Clip

Clip 1038T

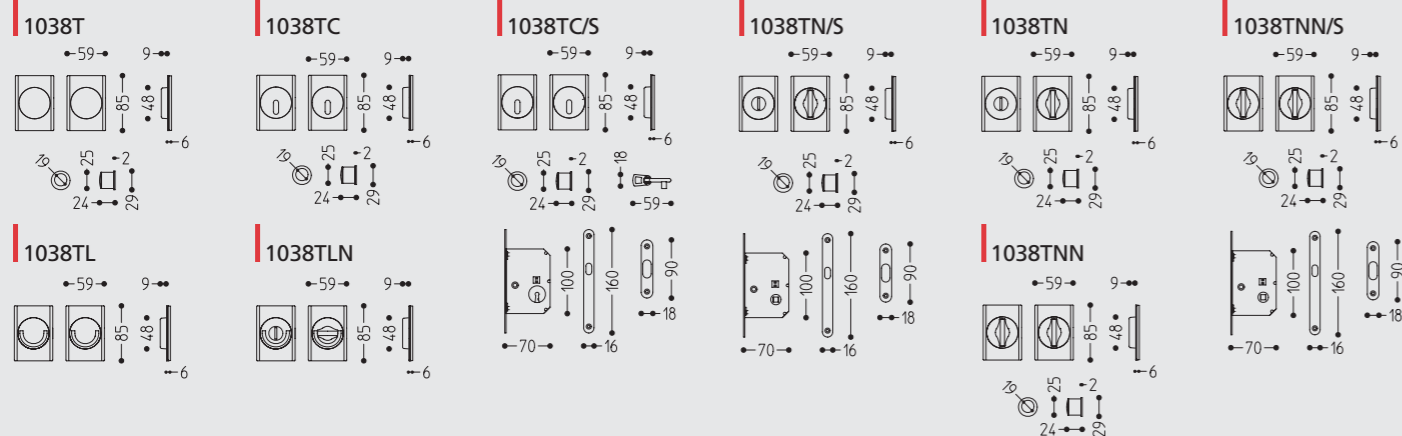

Finiture_Finishes

Materiale: **ottone pressofuso**
Material: **die cast brass**



Maniglia per porta scorrevole_Flush-handle for sliding door

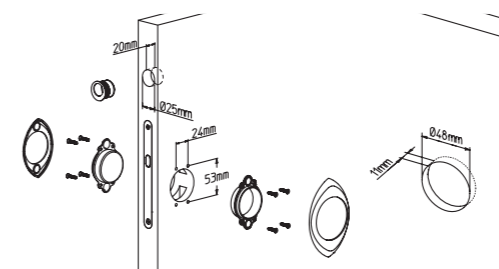

368



Kit maniglia per porta scorrevole,
spessore porta minimo 20 mm.

Flush-handle kit for sliding doors,
minimum door thickness 20 mm.

368C/S



Kit maniglia per porta scorrevole con foro
chiave completa di chiave a snodo e serratura.
Spessore porta 35+50 mm.

Flush-handle kit for sliding doors
with standard key-hole, foldable key and lock.
Door thickness 35+50 mm.

378



Kit maniglia per porta scorrevole,
spessore porta minimo 20 mm.

Flush-handle kit for sliding doors,
minimum door thickness 20 mm.

378C/S



Kit maniglia per porta scorrevole con foro
chiave completa di chiave a snodo e serratura.
Spessore porta 35+50 mm.

Flush-handle kit for sliding doors
with standard key-hole, foldable key and lock.
Door thickness 35+50 mm.

368

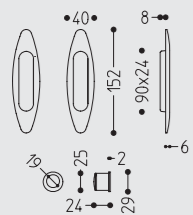

368C

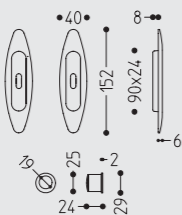

368C/S

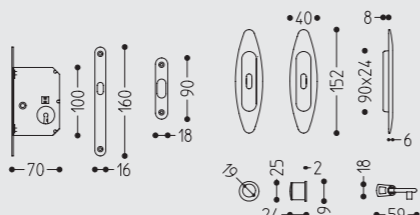

378

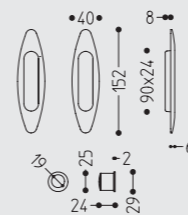

378C

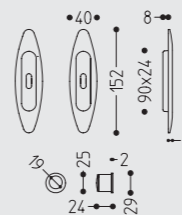

378C/S

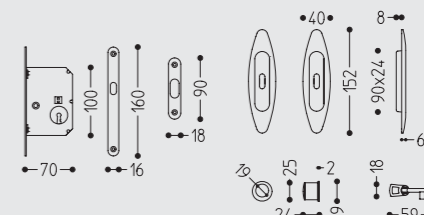

Finiture_Finishes

Materiale: **ottone pressofuso**
Material: **die cast brass**

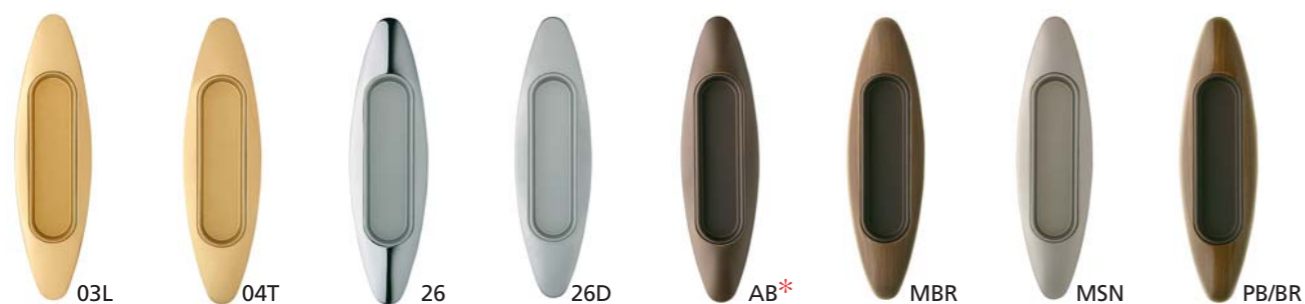

Finiture_Finishes

Materiale: **ottone pressofuso**
Material: **die cast brass**

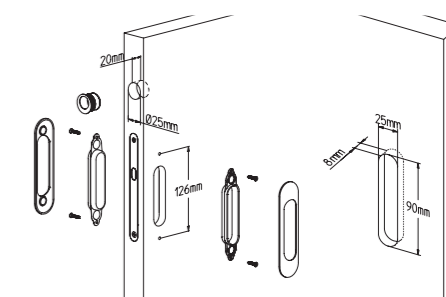
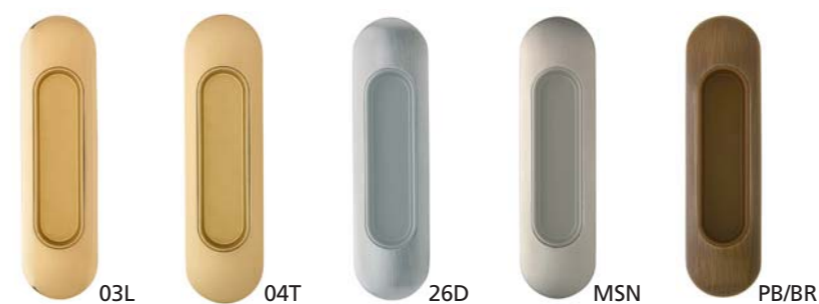

1018



Kit maniglia per porta scorrevole,
spessore porta minimo 20 mm.

Flush-handle kit for sliding doors,
minimum door thickness 20 mm.

1018C/S



Kit maniglia per porta scorrevole con foro
chiave completa di chiave a snodo e serratura.
Spessore porta 35+50 mm.

Flush-handle kit for sliding doors
with standard key-hole, foldable key and lock.
Door thickness 35+50 mm.

1028



Kit maniglia per porta scorrevole,
spessore porta minimo 20 mm.

Flush-handle kit for sliding doors,
minimum door thickness 20 mm.

1028C/S



Kit maniglia per porta scorrevole con foro
chiave completa di chiave a snodo e serratura.
Spessore porta 35+50 mm.

Flush-handle kit for sliding doors
with standard key-hole, foldable key and lock.
Door thickness 35+50 mm.

1018

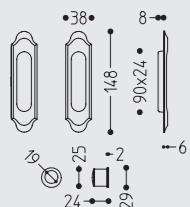

1018C

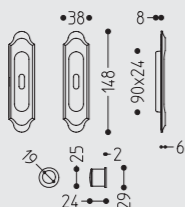

1018C/S

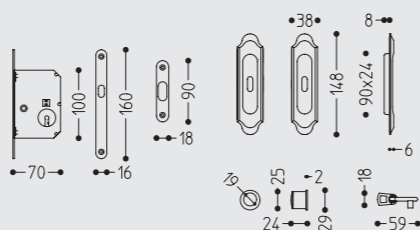

1028

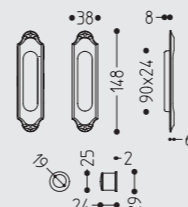

1028C

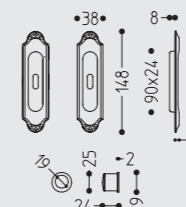

1028C/S

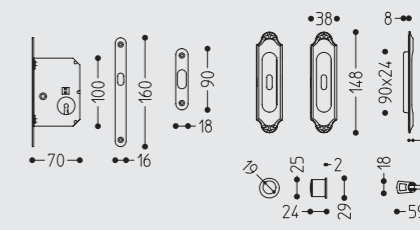

Finiture_Finishes

Materiale: **ottone pressofuso**
Material: **die cast brass**

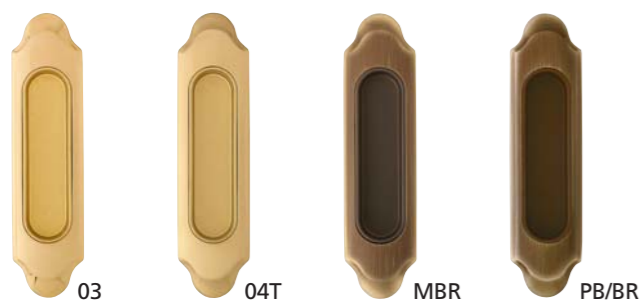

Finiture_Finishes

Materiale: **ottone pressofuso**
Material: **die cast brass**

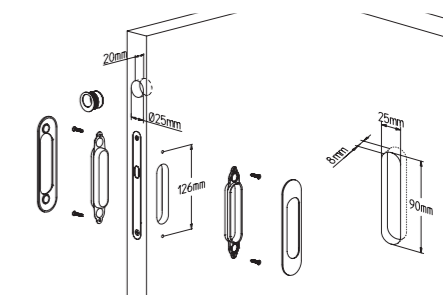
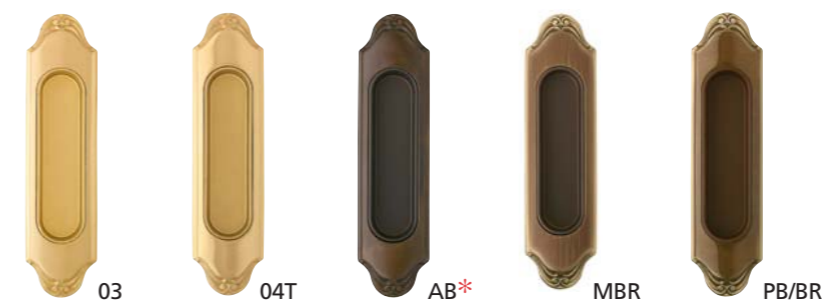

1038



Kit maniglia per porta scorrevole, spessore porta minimo 20 mm.

Flush-handle kit for sliding doors, minimum door thickness 20 mm.

1038C/S



Kit maniglia per porta scorrevole con foro chiave completa di chiave a snodo e serratura. Spessore porta 35+50 mm.

Flush-handle kit for sliding doors with standard key-hole, foldable key and lock. Door thickness 35+50 mm.

MANIGLIE PER PORTE SCORREVOLI FLUSH-HANDLES

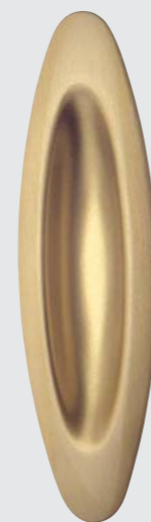

258
03
04
26
26D



S18
03
04
26
26D
AB* (senza sfumatura-shaded)
PB/BR
SNF

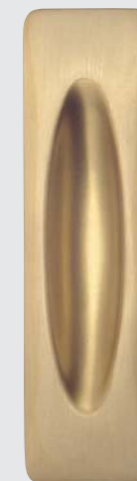

3008
03
04
26
26D
MBR
MSN

1038

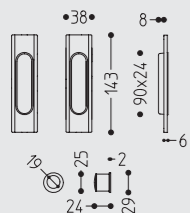

1038C

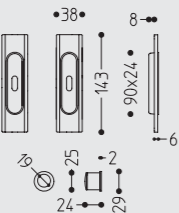

1038C/S

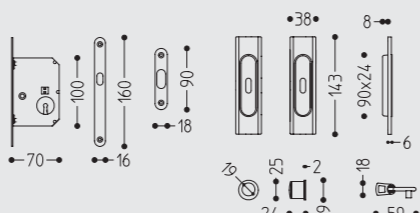

2214/AP
2214/BP
A COPPIA_PAIR
03
04
26
26D
AB*
SNF

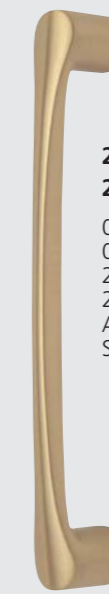

2214/AC
2214/BC
03
04
26
26D
AB*
SNF

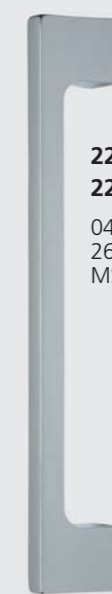

2239/A1-C
2239/AC
04T
26D
MSN

Finiture_Finishes

Materiale: ottone pressofuso
Material: die cast brass

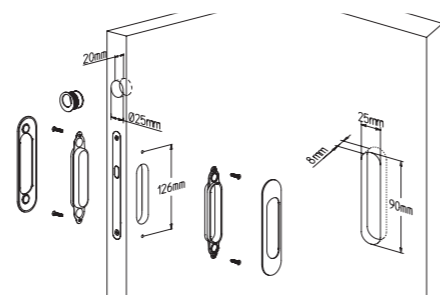

258

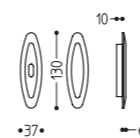

S18

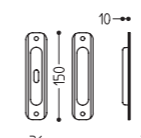

2214/AC

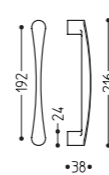

2214/BC

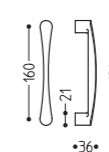

2214/AP

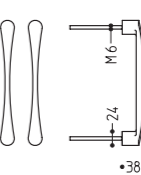

2214/BP

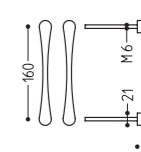

2239/AC

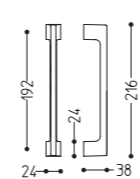

2239/A1C

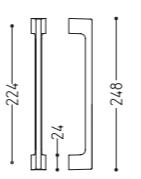

2239/AP

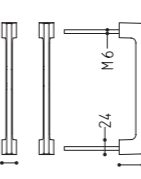

2239/A1P

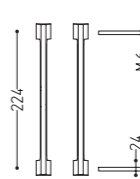

3008

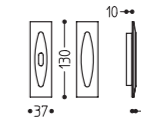

* La finitura AB è ottenuta con processi naturali, che come tali non consentono l'uniformità di colore e di tonalità fra i singoli pezzi.
The AB finish is obtained with natural elements that do not allow colour consistence from piece to piece.

196

197

MAN. ALZANTI SCORREVOLI_PULL-UP HANDLES 196

MAN. ALZANTI SCORREVOLI_PULL-UP HANDLES 197

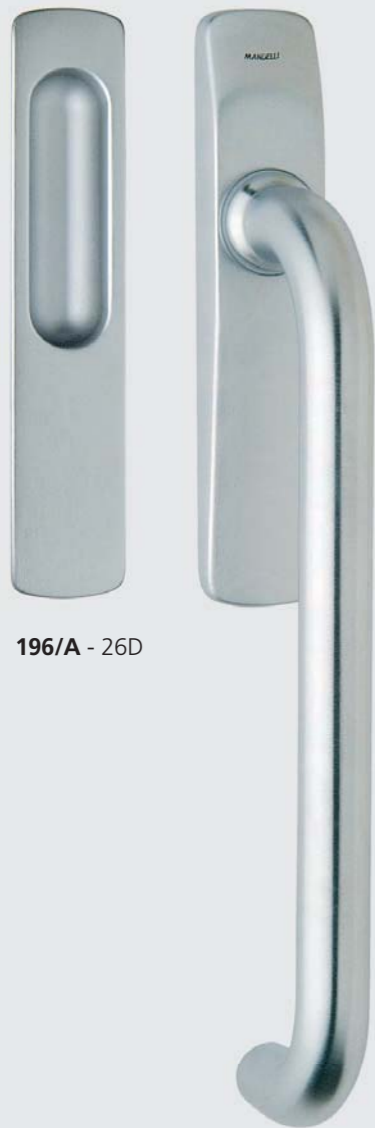

196/A - 26D

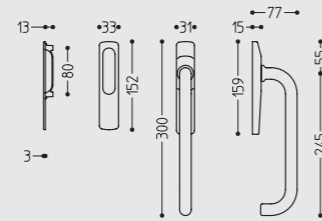

196/A

Maniglione alzante scorrevole completo di maniglia ad incasso (con/senza foro cilindro) **Lunghezza impugnatura 245 mm** - \varnothing 10 mm

Patented mechanism pull-up handle for sliding door complete with flush handle (with/without key-hole cylinder) **Pull length 245 mm** - \varnothing 10 mm

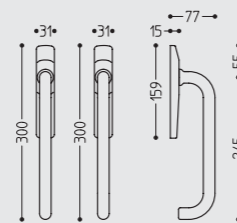

196/A-P

Maniglione alzante scorrevole a coppia (con/senza foro cilindro) **Lunghezza impugnatura 245 mm** - \varnothing 10 mm

Patented mechanism pull-up handle pair (with/without key-hole cylinder) **Pull length 245 mm** - \varnothing 10 mm

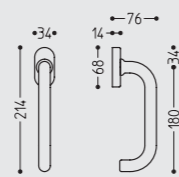

196/B

Maniglione DK **Lunghezza impugnatura 180 mm** \varnothing 7 mm

Pull-up handle DK for sliding door **Pull length 180 mm** \varnothing 7 mm

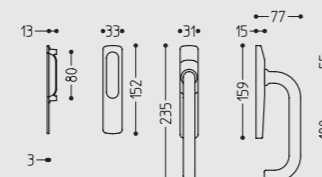

196/C

Maniglione alzante scorrevole completo di maniglia ad incasso (con/senza foro cilindro) **Lunghezza impugnatura 180 mm** - \varnothing 10 mm

Patented mechanism pull-up handle for sliding door complete with flush handles (with/without key-hole cylinder) **Pull length 180 mm** - \varnothing 10 mm

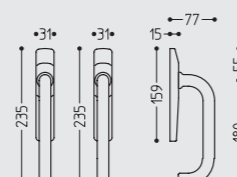

196/C-P

Maniglione alzante scorrevole a coppia (con/senza foro cilindro) **Lunghezza impugnatura 180 mm** \varnothing 10 mm

Patented mechanism pull-up handle-pair (with/without key-hole cylinder) **Pull length 180 mm** - \varnothing 10 mm



197/A - 26D/26

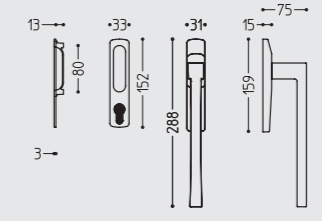

197/A

Maniglione alzante scorrevole completo di maniglia ad incasso (con/senza foro cilindro) **Lunghezza impugnatura 233 mm** - \varnothing 10 mm

Patented mechanism pull-up handle for sliding door complete with flush handle (with/without key-hole cylinder) **Pull length 233 mm** - \varnothing 10 mm

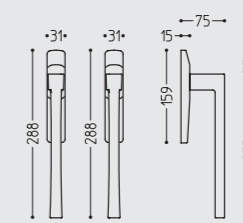

197/A-P

Maniglione alzante scorrevole a coppia (con/senza foro cilindro) **Lunghezza impugnatura 233 mm** - \varnothing 10 mm

Patented mechanism pull-up handle pair (with/without key-hole cylinder) **Pull length 233 mm** - \varnothing 10 mm

196/A - 196/A-P - 196/C - 196/C-P
movimento 4 scatti_4 releases

Finiture_Finishes

Materiale: **ottone pressofuso**
Material: **die cast brass**

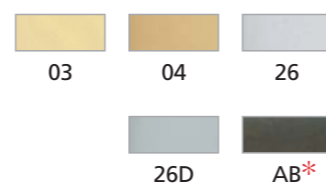

197/A - 197/A-P
movimento 4 scatti_4 releases

Finiture_Finishes

Materiale: **ottone pressofuso**
Material: **die cast brass**

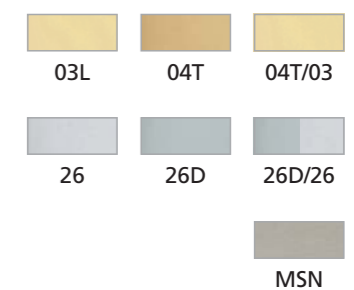

* La finitura AB è ottenuta con processi naturali, che come tali non consentono l'uniformità di colore e di tonalità fra i singoli pezzi.

The AB finish is obtained with natural elements that do not allow colour consistence from piece to piece.



160/R

FIX-VI Maniglione con rosetta Screwed-on pull

Sistema di fissaggio brevettato Fix-Vi.
Materiale: porte in legno.
Spessore: > 20 mm.
Sistema di fissaggio già incluso
nella confezione.

Patented fixing system Fix-Vi.
Material: wood doors.
Door thickness: > 20 mm.
Available in box.

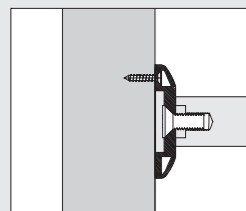

AB*

3025/R-B

FIX-PE Maniglione con perno Pull on dummy bolt

Sistema di fissaggio brevettato Fix-Pe.
Materiale: porte in legno.
Spessore: > 20 mm.
Sistema di fissaggio già incluso
nella confezione.

Patented fixing system Fix-Pe.
Material: wood doors.
Door thickness: > 20 mm.
Available in box.

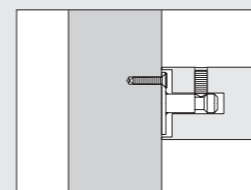

03

160/R DX-SX

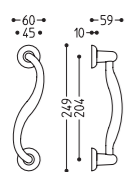

160/R-C

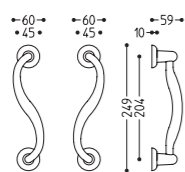

160/R-P

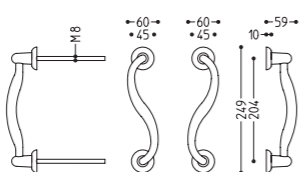

Finiture_Finishes

Materiale: **ottone pressofuso**
Material: **die cast brass**

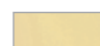

03



AB*



PB/BR

3025/R-B

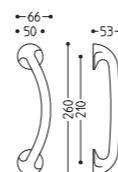

Finiture_Finishes

Materiale: **ottone pressofuso**
Material: **die cast brass**



03



26



26D



PB/BR

* La finitura AB è ottenuta con processi naturali, che come tali non consentono l'uniformità di colore e di tonalità fra i singoli pezzi.

The AB finish is obtained with natural elements that do not allow colour consistence from piece to piece.



465



465 - 26D

465/L

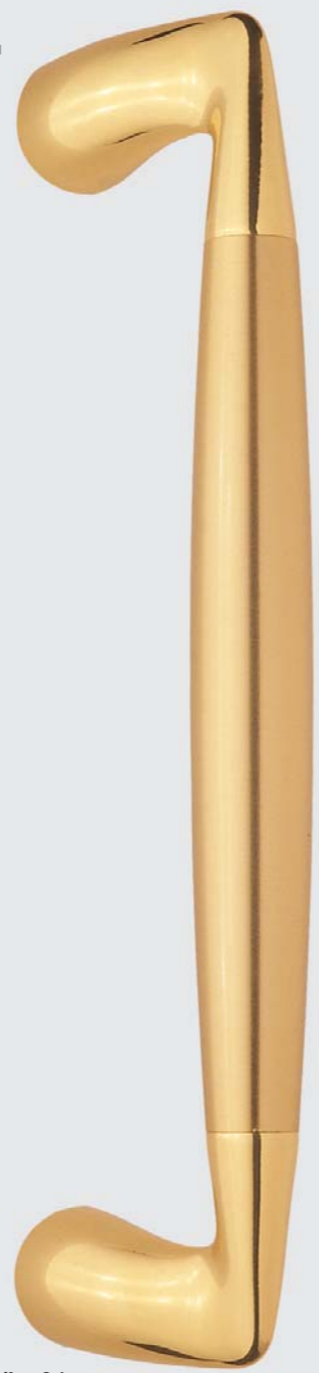

465/L - 04

495



MSN

465

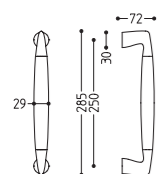

465/L

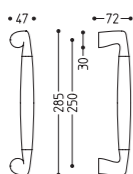

TUTTO OTTONE
FULL BRASS



03P



04



26D

OTTONE/CILIEGIO
BRASS/CHERRY WOOD



26/CHE



26D/CHE

OTTONE/WENGÈ
BRASS/WENGÈ



26/WEN



26D/WEN

495

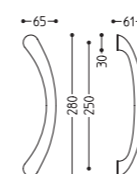

Finiture_Finishes

Materiale: **ottone pressofuso**
Material: **die cast brass**

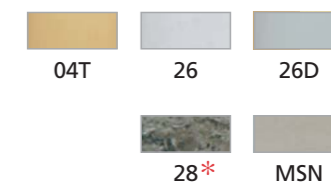

* La finitura 28 è ottenuta con processi naturali, che come tali non consentono l'uniformità di colore e di tonalità fra i singoli pezzi.

The 28 finish is obtained with natural elements that do not allow colour consistence from piece to piece.

775



26D

995



26D

775

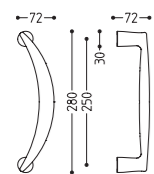

Finiture_Finishes

Materiale: **ottone pressofuso**
Material: **die cast brass**



995

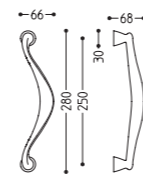

Finiture_Finishes

Materiale: **ottone pressofuso**
Material: **die cast brass**

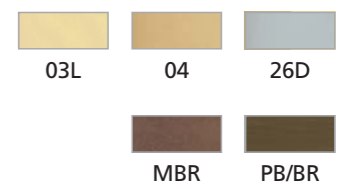

1035



26DT

1035

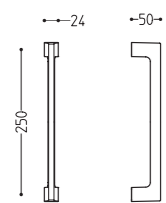

Finiture_Finishes

Materiale: **ottone**
Material: **brass**

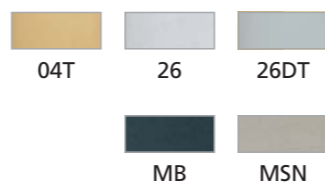

1125



03

1125

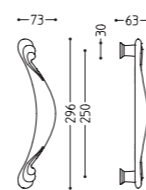

Finiture_Finishes

Materiale: **ottone pressofuso**
Material: **die cast brass**

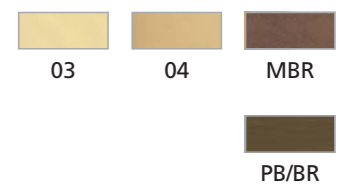

1155

1255

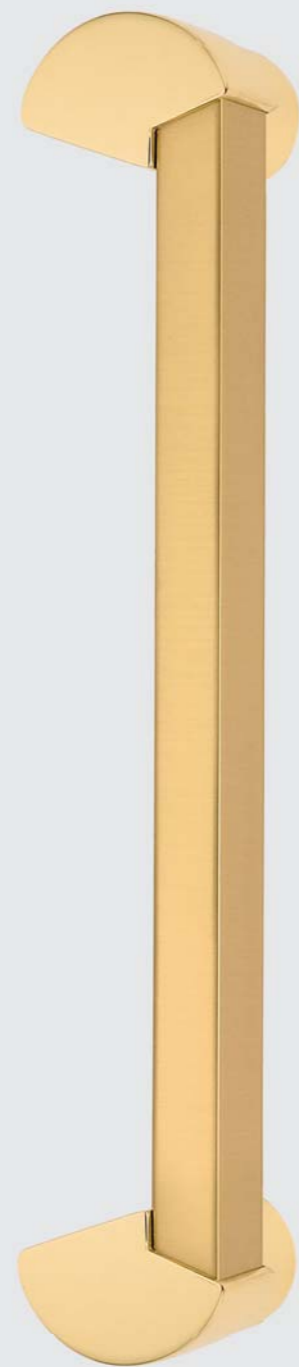

04

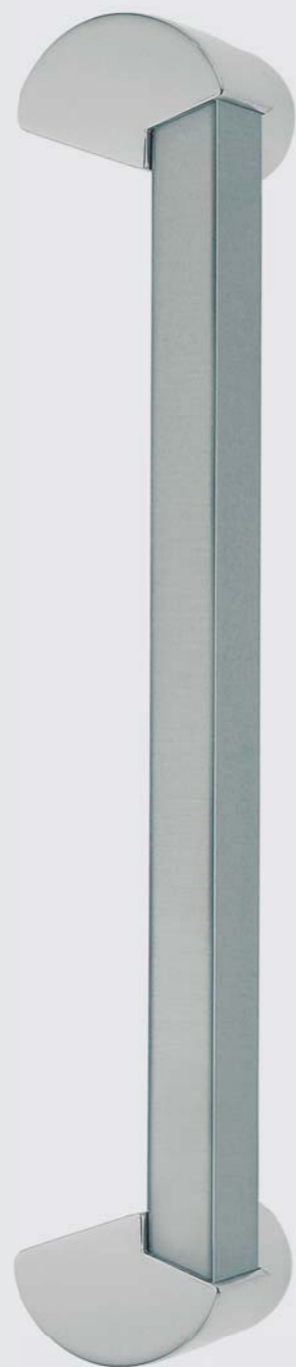

26D



26DT

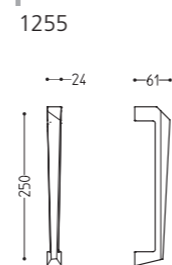
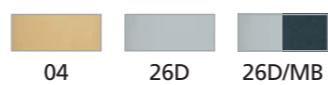
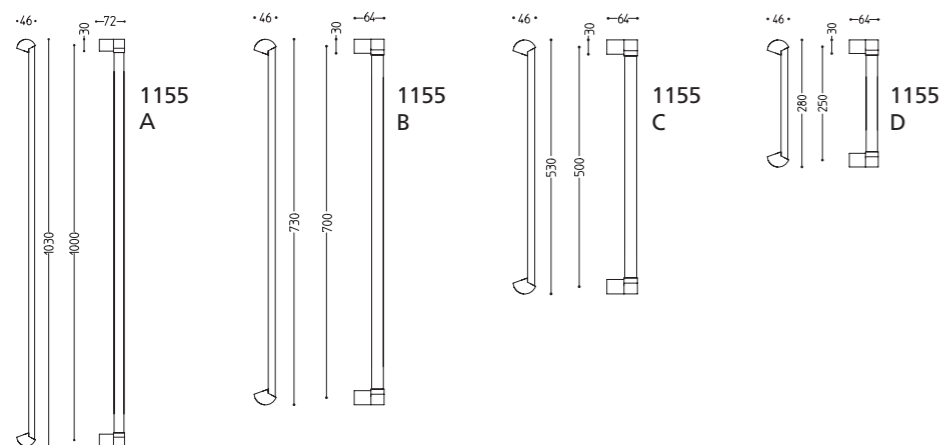

Finiture_Finishes

Materiale: **ottone**
Material: **brass**



1305

1315



26

03L

1305

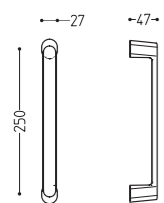

Finiture_Finishes

Materiale: **ottone**
Material: **brass**

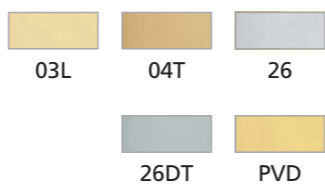

1315

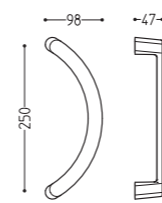

Finiture_Finishes

Materiale: **ottone**
Material: **brass**

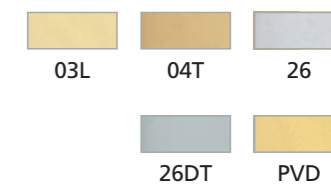

Sistemi di fissaggio per maniglioni

Fixing systems for door-pulls

KIT 01 fissaggio maniglione singolo

Fixing kit for single pull

Materiale Material	Spessore Door Thickness	Foro Drill	Profondità Depth hole
Porte in legno Wooden doors	> 30 mm	Ø 10 mm	25 mm

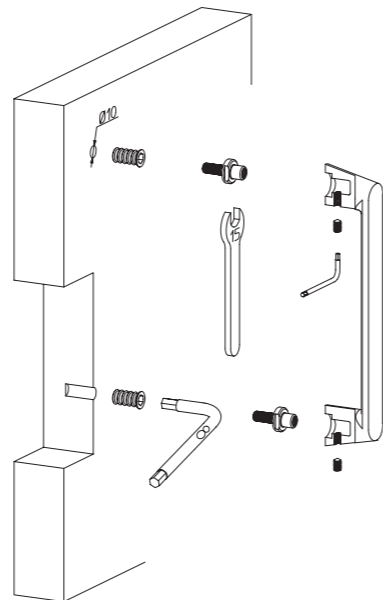
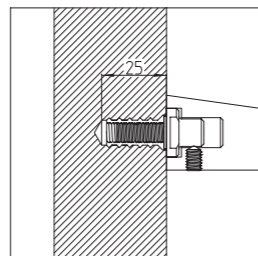

Sistemi di fissaggio per maniglioni

Fixing systems for door-pulls

KIT 03/911 fissaggio maniglione con rosetta tonda

Fixing kit for pull on round rose

Materiale Material	Spessore Door Thickness
Porte in legno Wooden doors	> 20 mm

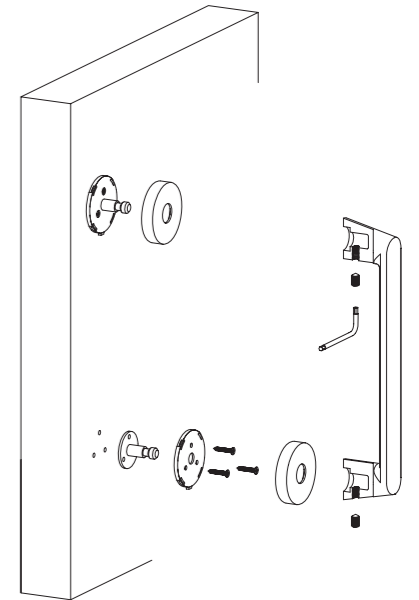
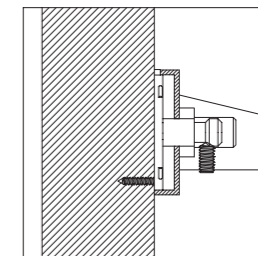

KIT 02 fissaggio maniglione singolo con passante

Fixing kit for single pull-bolt through

Materiali Material	Spessore Door Thickness	Foro Drill
Porte in legno Wooden doors	10 ↔ 80 mm	Ø 10 mm
Porte in PVC PVC doors	10 ↔ 80 mm	Ø 10 mm
Porte in alluminio Aluminium doors	10 ↔ 80 mm	Ø 10 mm

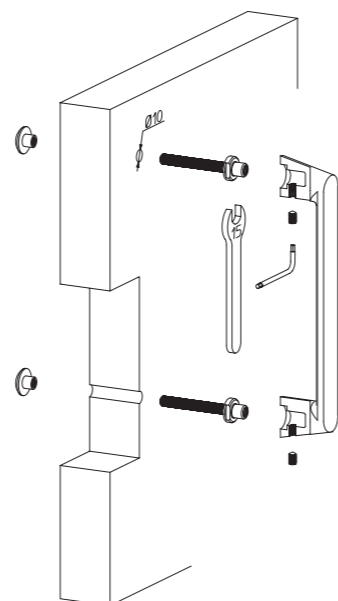
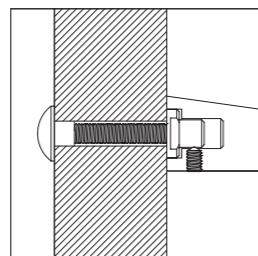
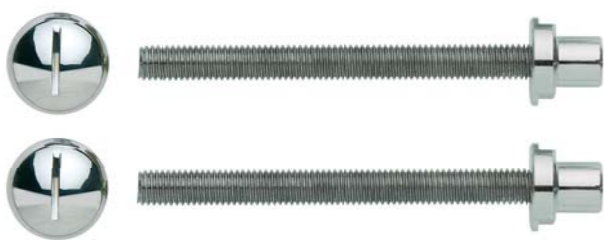

KIT 03/1161 fissaggio maniglione con rosetta quadra

Fixing kit for pull on square rose

Materiale Material	Spessore Door Thickness
Porte in legno Wooden doors	> 20 mm

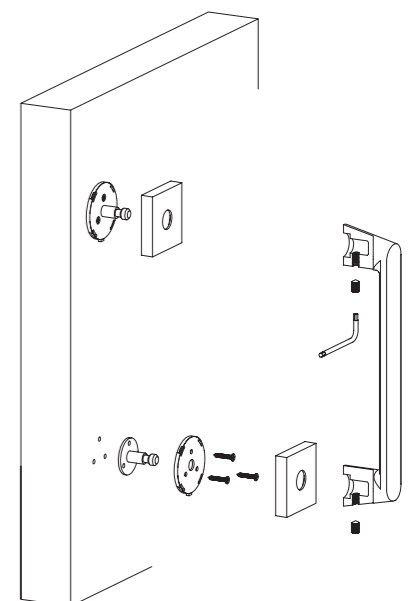
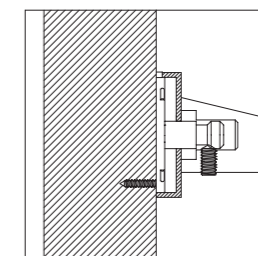

Sistemi di fissaggio per maniglioni

Fixing systems for door-pulls

KIT 04 fissaggio maniglione singolo con passante su vetro

Fixing kit for single pull-bolt through on glass doors

Materiale Material	Spessore Door Thickness	Foro Drill
Porte in vetro Glass doors	> 10 mm	Ø 12 mm

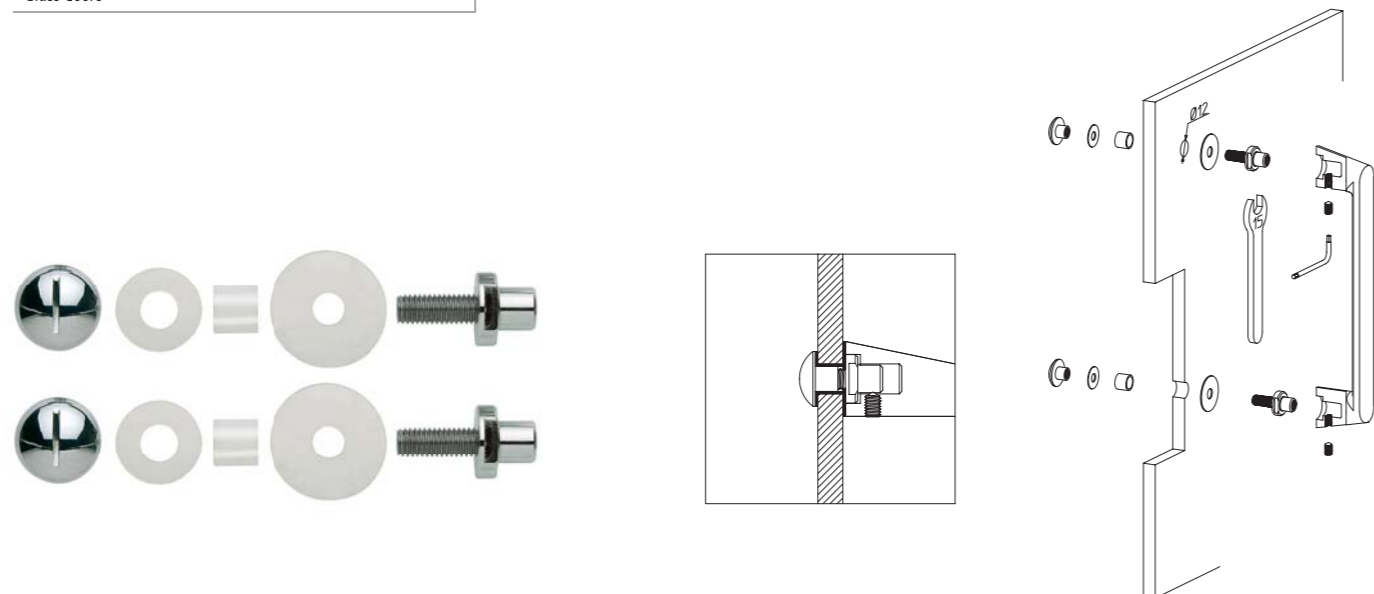

Sistemi di fissaggio per maniglioni

Fixing systems for door-pulls

KIT 06 fissaggio maniglione a coppia

Fixing kit for pull pair

Materiale Material	Spessore Door Thickness	Foro Drill
Porte in legno Wooden doors	10 ↔ 80 mm	Ø 8 mm
Porte in PVC PVC doors	10 ↔ 80 mm	Ø 8 mm
Porte in alluminio Aluminium doors	10 ↔ 80 mm	Ø 8 mm

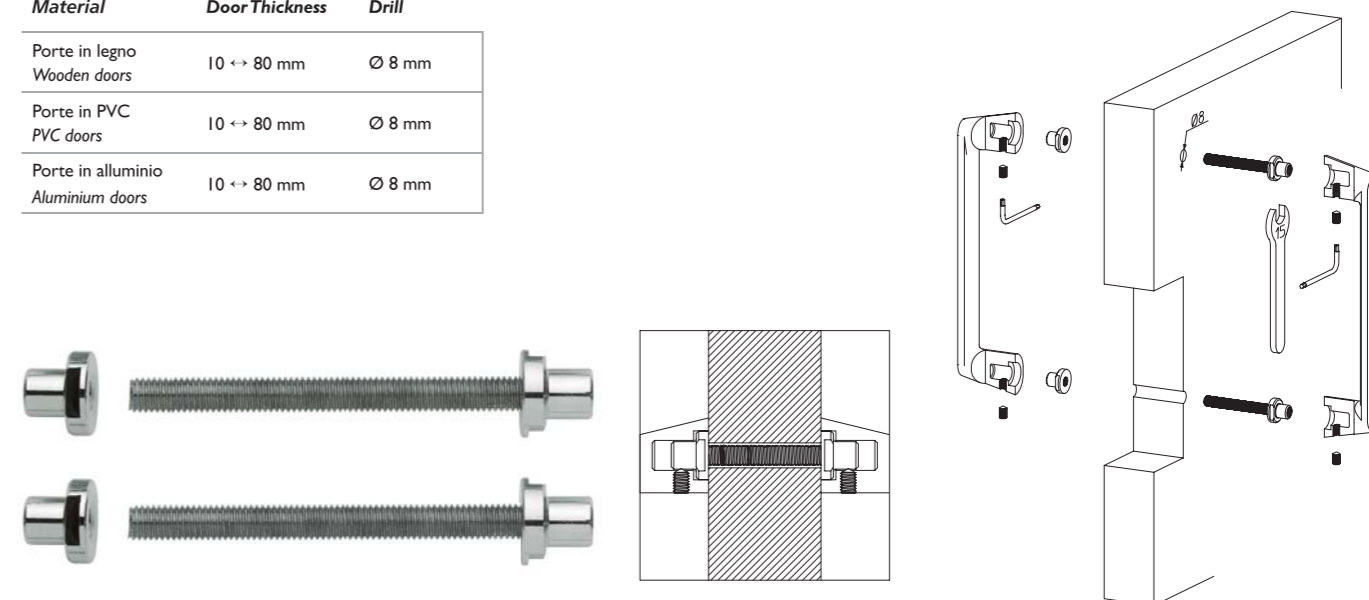

KIT 05 fissaggio maniglione singolo su porte in alluminio o PVC

Fixing kit for single pull on aluminium or pvc doors

Materiale Material	Spessore Door Thickness	Foro Drill
Porte in alluminio Aluminium doors	1,5 ↔ 3 mm	Ø 13 mm
Porte in PVC PVC doors	1,5 ↔ 3 mm	Ø 13 mm

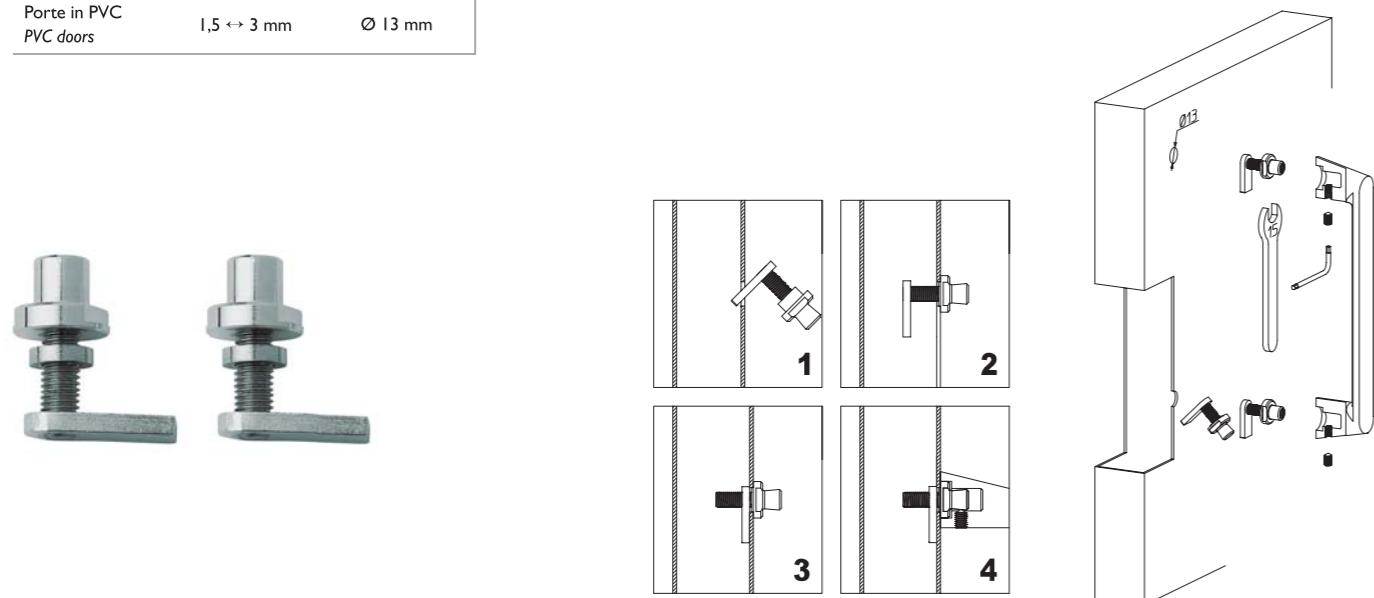

KIT 07 fissaggio maniglione a coppia su vetro

Fixing kit for pull pair on glass door

Materiale Material	Spessore Door Thickness	Foro Drill
Porte in vetro Glass doors	> 10 mm	Ø 12 mm

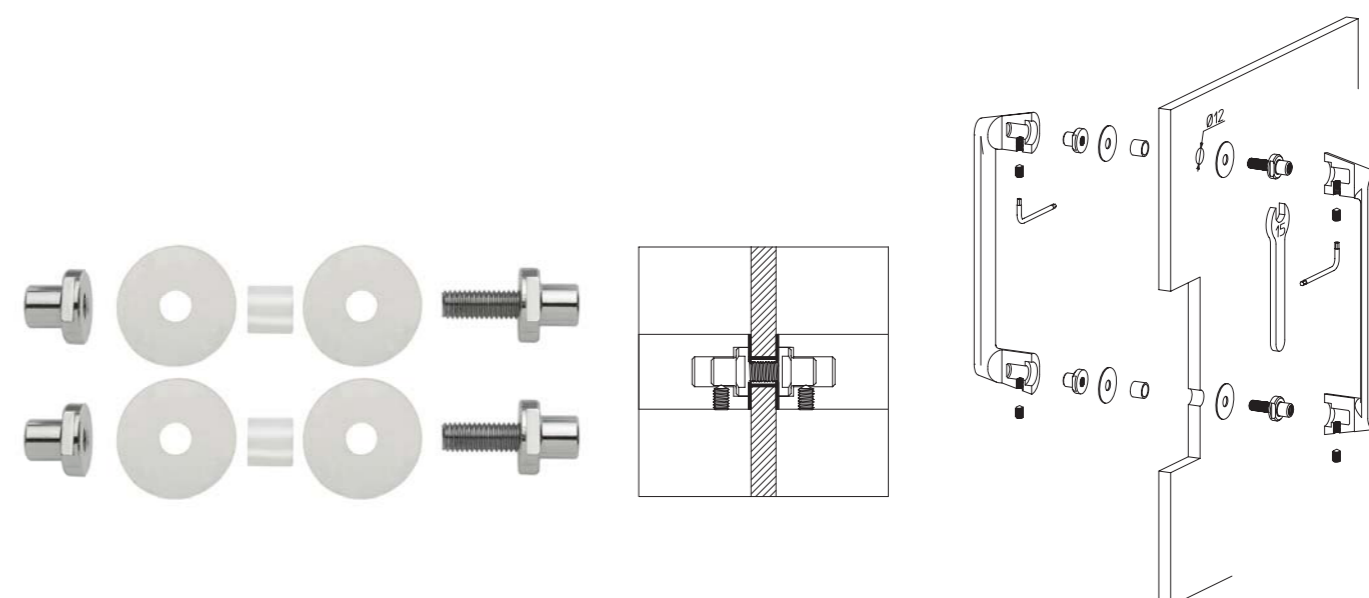

Sistemi di fissaggio per maniglioni

Fixing systems for door-pulls

KIT 08/60 o 08/75 fissaggio maniglione singolo su porte in legno con maniglia

Fixing kit for single pull on wooden doors with lever handle

Materiale Material	Spessore Door Thickness	Foro Drill
Porte in legno Wooden doors	60 mm (kit tipo 08/60)	Ø 10 mm
	75 mm (kit tipo 08/75)	

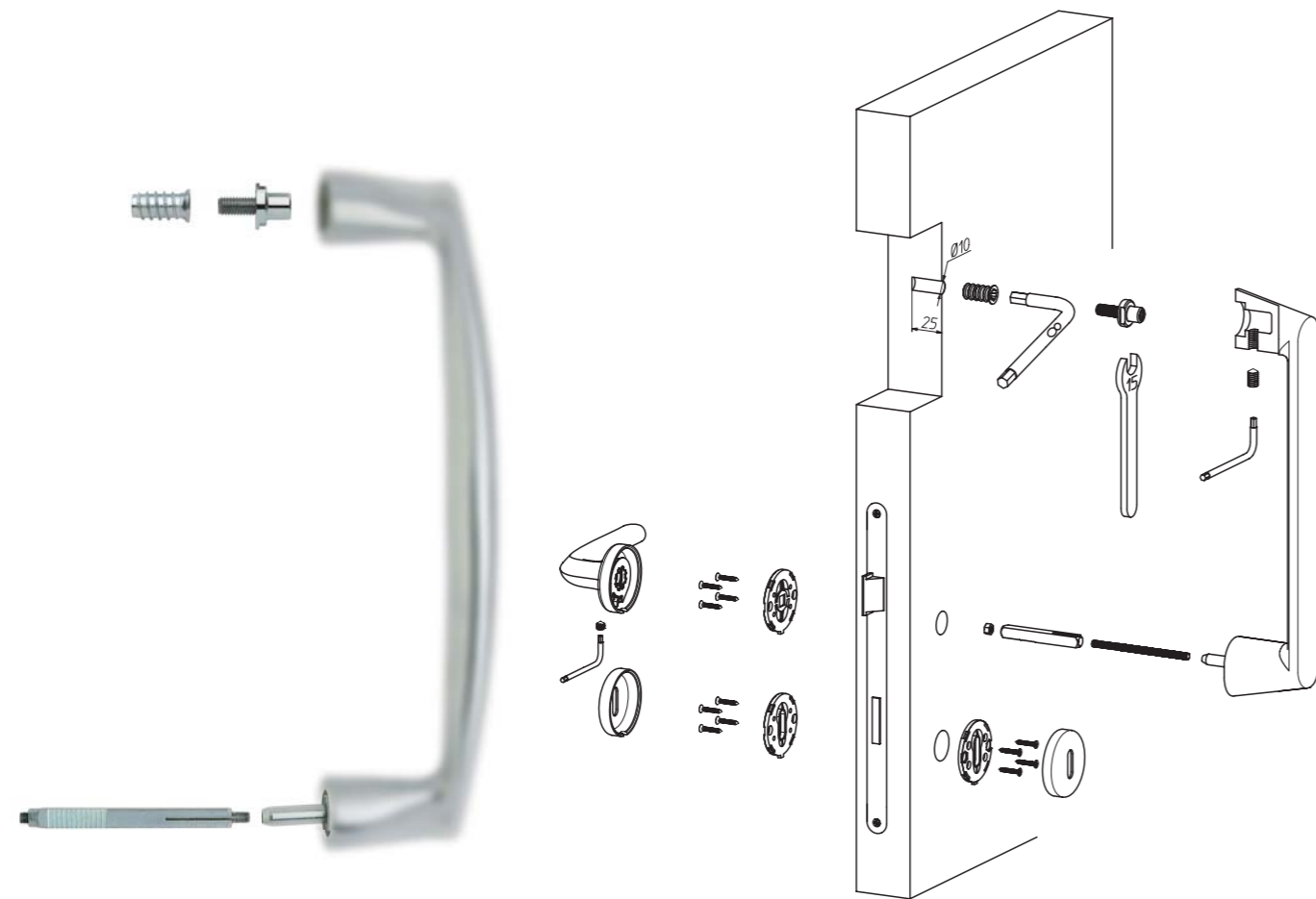

Kit da richiedere in fase di ordine in quanto premontato direttamente sul maniglione.

Kit to be requested on order, as pre-assembling on pull.

Sistemi di fissaggio per maniglioni

Fixing systems for door-pulls

KIT 09/60 o 09/75 fissaggio maniglione singolo su porte in alluminio o PVC con maniglia

Fixing kit for single pull on aluminium or PVC doors with lever handle

Materiale Material	Spessore Door Thickness	Foro Drill
Porte in alluminio o PVC Aluminium or PVC doors	sez. max 3 mm tot. 60 mm (kit tipo 09/60)	Ø 13 mm
	sez. max 3 mm tot. 75 mm (kit tipo 09/75)	

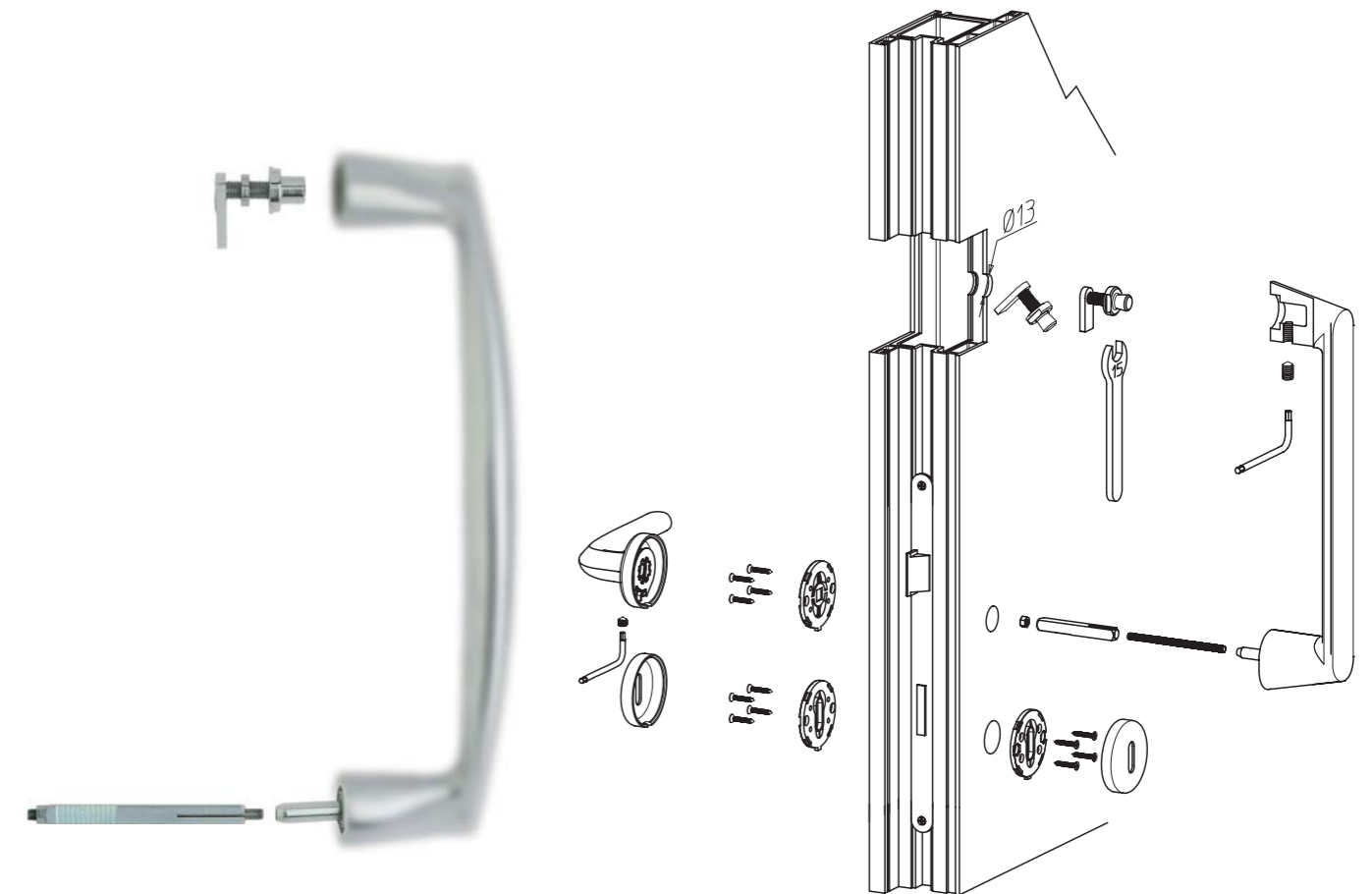

Kit da richiedere in fase di ordine in quanto premontato direttamente sul maniglione.

Kit to be requested on order, as pre-assembling on pull.

284



644

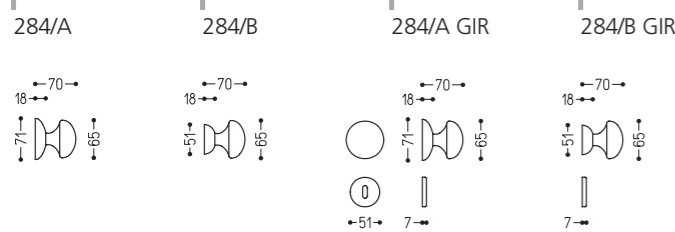

Finiture_Finishes

Materiale: **ottone pressofuso**
Material: **die cast brass**

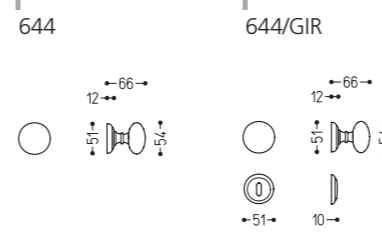
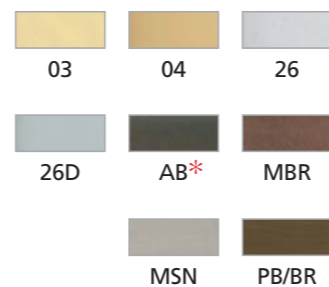

Finiture_Finishes

Materiale: **ottone pressofuso**
Material: **die cast brass**

Decoro porcellana
Porcelain decor

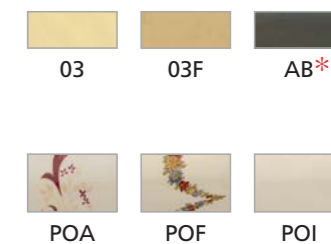

524



744

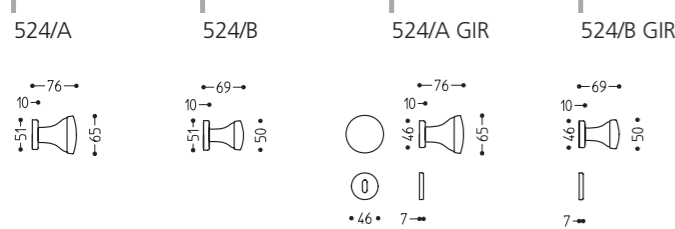
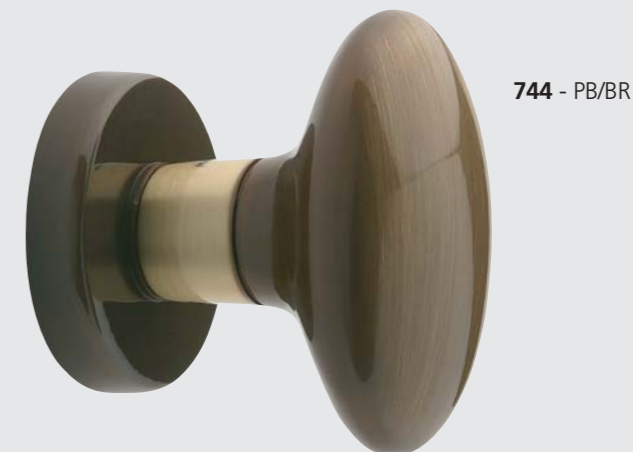

Finiture_Finishes

Materiale: **ottone pressofuso**
Material: **die cast brass**

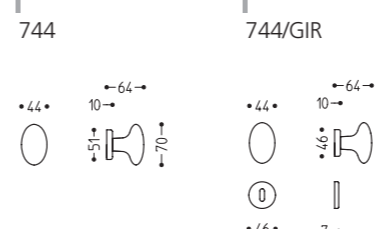
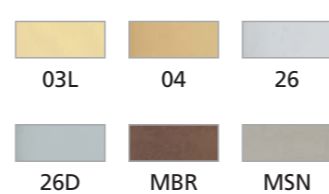

Finiture_Finishes

Materiale: **ottone pressofuso**
Material: **die cast brass**

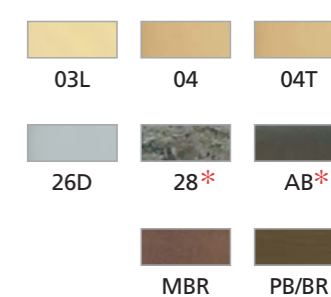

* La finitura **AB** è ottenuta con processi naturali, che come tali non consentono l'uniformità di colore e di tonalità fra i singoli pezzi.

The **AB** finish is obtained with natural elements that do not allow colour consistence from piece to piece.



* Le finiture **28** e **AB** sono ottenute con processi naturali, che come tali non consentono l'uniformità di colore e di tonalità fra i singoli pezzi.

The **28** and **AB** finishes are obtained with natural elements that do not allow colour consistence from piece to piece.

854



854 - PB/BR

854

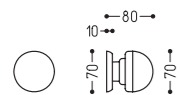

854/GIR

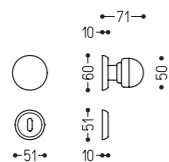

Finiture_Finishes

Materiale: **ottone pressofuso**
Material: **die cast brass**

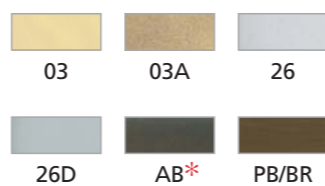

1104



1104 - MBR/POI

1104

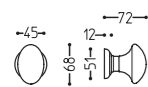

1104/GIR

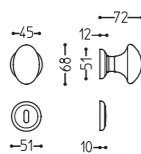

Finiture_Finishes

Materiale: **ottone pressofuso**
Material: **die cast brass**

Decoro porcellana
Porcelain decor



1024



1024/A Ø90 - MBR



1024/B Ø72 - MBR



1024/GIR - MBR



1024/A - Ø90

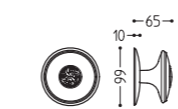

1024/B - Ø72

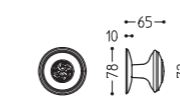

1024/GIR

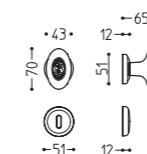

Finiture_Finishes

Materiale: **ottone pressofuso**
Material: **die cast brass**



* La finitura AB è ottenuta con processi naturali, che come tali non consentono l'uniformità di colore e di tonalità fra i singoli pezzi.

The AB finish is obtained with natural elements that do not allow colour consistence from piece to piece.



3114



3114 - 26/BRI

3114

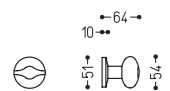

3114/GIR

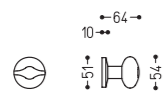

Finiture_Finishes

Materiale: **ottone pressofuso**
Material: **die cast brass**

Ottone/Radica Brass/Briarwood	Ottone/Pero Brass/Pear wood	Ottone/Teak Brass/Teak wood
03/BRI	26/PEA	26/TEA
26/BRI	26D/PEA	26D/TEA
26D/BRI		

ACCESSORI PER PORTA DOOR-FITTINGS



101 - 26D
03
04
26
26D
AB*
PVD



102 - AB*
03
04
AB*

3124



3124 - 26D

3124

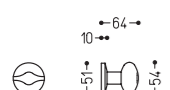

3124/GIR

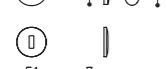

Finiture_Finishes

Materiale: **ottone pressofuso**
Material: **die cast brass**

04	26D
----	-----

101

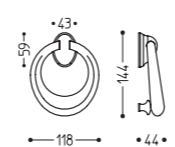

102

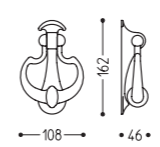

106

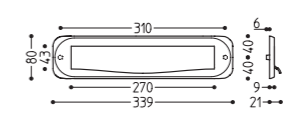

106 - 03
03
26D
AB*
PB/BR



* La finitura AB è ottenuta con processi naturali, che come tali non consentono l'uniformità di colore e di tonalità fra i singoli pezzi.

The AB finish is obtained with natural elements that do not allow colour consistence from piece to piece.

ACCESSORI PER PORTA DOOR-FITTINGS

PORTABITI COAT-HOOKS



200/C - 03
03 / 04 / 26 / 26D / AB* / PB/BR

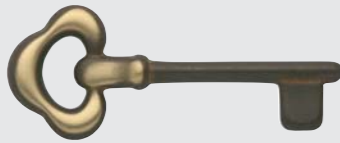

650/C - PB/BR
03 / 03A / 04 / AB* / PB/BR



710/C - 26D
03 / 04 / 26 / 26D / MBR / MSN / SNF



S10/C - 04
03 / 04 / 26 / 26D / SNF



109 - 26D
03 / 03A / 04 / 26 / 26D / AB*
MBR / MSN / PB/BR / SNF



113/RFV - 03
03 / 03A / 04 / 26 / 26D / 27 / 28*
AB* / MBR / MSN / PB/BR / SNF



114/RFV - 26D
03 / 03A / 03LX* / 04 / 26 / 26D / 27
AB* / MBR / PB/BR / SNF



1161-114/RFV - 26DT
03L / 04T / 26 / 26DT / MB / MSN / MTC



84 - 26D
03 / 26 / 26D

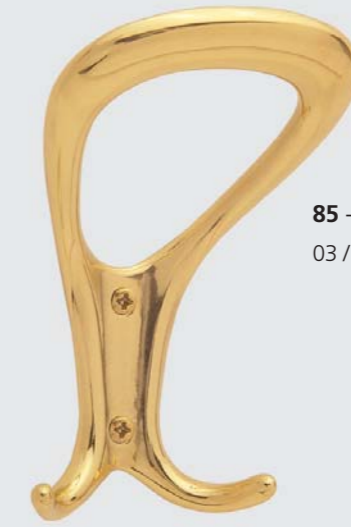

85 - 03
03 / 04 / 26 / 26D / AB*



86 - 26D
03 / 04 / 26 / 26D / AB*



87 - 26D
03 / 26 / 26D / MBR / MSN / MTC

200/C



650/C



710/C

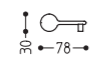

S10/C



109



84

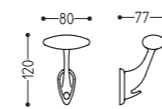

85

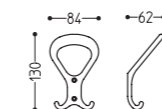

86

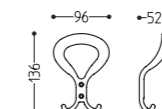

87

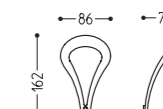

113/RFV

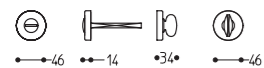

114/RFV

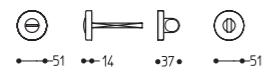

1161-114/RFV

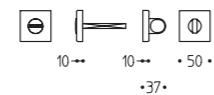

* Le finiture 03LX, 28 e AB sono ottenute con processi naturali, che come tali non consentono l'uniformità di colore e di tonalità fra i singoli pezzi.

The 03LX, 28 and AB finishes are obtained with natural elements that do not allow colour consistence from piece to piece.



* La finitura AB è ottenuta con processi naturali, che come tali non consentono l'uniformità di colore e di tonalità fra i singoli pezzi.

The AB finish is obtained with natural elements that do not allow colour consistence from piece to piece.

PORTABILI COAT-HOOKS



88 - 26D
26 / 26D / MBR
MSN / MTC



90/A



90/C

90/A-B-C-D - 26D
03L / 26 / 26D / MBR
MSN / MTC



90/B



90/D



89 - 26D
26D / MBR / MSN / MTC



91 - 26D
03L / 04T / 26DT / MBR



92 - 26DT
04T / 26DT / MB/26



94 - 26DT
04T / 26DT / MB/26

88

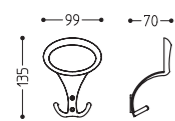

90/A

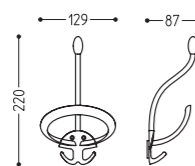

90/B

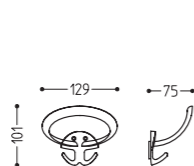

90/C

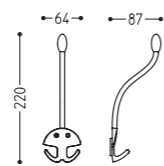

90/D



91

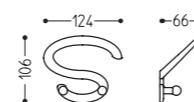

92

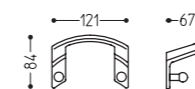

94

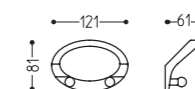

89

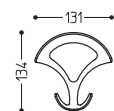

POMOLI PER MOBILI CABINET-KNOBS

2005 - 26D



design Studio Mandelli

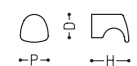

MISURA	D	H	P
A	20	32	24
B	18	26	19

Finiture_Finishes
03 / 26 / 26D / PB/BR

2006 - PB/BR



design Studio Mandelli

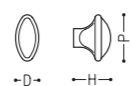

MISURA	D	H	P
A	20	32	40
B	16	26	32

Finiture_Finishes
03 / 26 / 26D / AB*/ PB/BR

2007 - 03



design Studio Mandelli

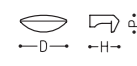

MISURA	D	H	P
A	40	25	14
B	25	25	13
C	16	25	12

Finiture_Finishes
03 / 26 / 26D / PB/BR

2008 - PB/BR

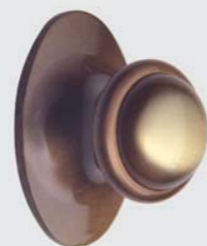

design Studio Mandelli

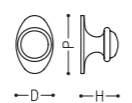

MISURA	D	H	P
A	32	32	50
B	25	25	39

Finiture_Finishes
03 / AB*/ PB/BR

2019 - 26D



design Studio Mandelli

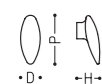

MISURA	D	H	P
A	22	29	50
B	19	27	47
C	17	22	40

Finiture_Finishes
03 / 04 / 26 / 26D / AB*

2021 - 26D



design Studio Mandelli

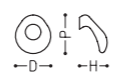

MISURA	D	H
A	38	26
B	32	23
C	27	19

Finiture_Finishes
03 / 04 / 26 / 26D / AB*/ PB/BR

2022 - 26D

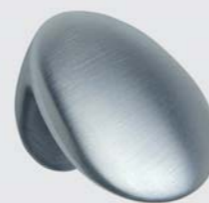

design Luciano Vaghi



MISURE INDICATIVE		
MISURA	D	H
A	37	30
B	30	25

Finiture_Finishes
03 / 04 / 26 / 26D / MBR / MSN

2023 - 26D



design Luciano Vaghi

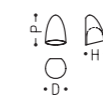

MISURA	D	H	P
A	35	34	51

Finiture_Finishes
03 / 04 / 26 / 26D / MBR / MSN

2024 - 03A



design Matt Johnson

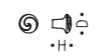

MISURA	D	H
A	32	32
B	25	25

Finiture_Finishes
03A / MBR / PB/BR

2025 - 03



design Luciano Vaghi

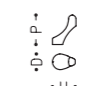

MISURA	D	H	P
A	27	39	50

Finiture_Finishes
03 / 04 / 26 / 26D / MSN

2026 - 03



design Takahide Sano

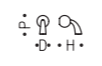

MISURA	D	H	P
A	18	37	32
B	14	30	25

Finiture_Finishes
03 / 04 / 26 / 26D / MBR / MSN

2027 - 04

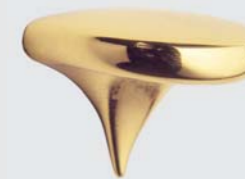

design Luciano Vaghi

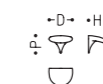

MISURA	D	H	P
A	40	30	30
B	30	25	25

Finiture_Finishes
04 / 26 / 26D / MBR / MSN

2028 - 26D



design Takahide Sano

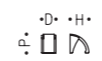

MISURA	D	H	P
A	24	32	32

Finiture_Finishes
04 / 26D / MSN

* La finitura AB è ottenuta con processi naturali, che come tali non consentono l'uniformità di colore e di tonalità fra i singoli pezzi.

The AB finish is obtained with natural elements that do not allow colour consistence from piece to piece.



MANIGLIE PER MOBILI CABINET-HANDLES

2201 - 03



design Studio Mandelli



MISURA	F	L
A	96	27
B	64	27

Finiture_Finishes
03

2204 - 26



design Studio Mandelli



MISURA	F	L
A	96	30
B	64	30

Finiture_Finishes
03 / 26 / 26D / AB*

2218 - 04



design Studio Mandelli



MISURA	F	L
B	160	30
C	128	30
D	96	25
E	64	21

Finiture_Finishes
03 / 04 / 26 / AB*

2219 - 04



design Studio Mandelli

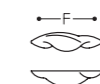

MISURA	F	L
D	96	27
E	64	25

Finiture_Finishes
03 / 04 / 26 / 26D / AB* / PB/BR

2205 - PB/BR



design Studio Mandelli



MISURA	F	L
A	96	30
B	64	30

Finiture_Finishes
03 / 26D / AB* / PB/BR

2206 - 26D



design Studio Mandelli



MISURA	F	L
A	96	30
B	64	30

Finiture_Finishes
03 / 26 / 26D / PB/BR

2220 - 26



design Studio Mandelli



MISURA	F	L
D	96	32
E	64	27

Finiture_Finishes
03 / 04 / 26 / AB* / PB/BR

2221 - 03



design Studio Mandelli



MISURA	F	L
D	96	35
E	64	32

Finiture_Finishes
03 / 04 / 26 / AB* / PB/BR

2214 - 26D



design Studio Mandelli



MISURA	F	L
A	192	38
B	160	38
C	128	35
D	96	32
E	64	30

Finiture_Finishes
03 / 04 / 26 / 26D / AB* / SNF

2215/DX-SX - 26



design Studio Mandelli



MISURA	F	L
C	128	32
D	96	30
E	64	27

Finiture_Finishes
03 / 04 / 26 / 26D

2223 - 26



design Studio Mandelli



MISURA	F	L
A	192	32
B	160	32
C	128	32
D	96	28

Finiture_Finishes
03 / 04 / 26 / 26D / AB*

2224 - 26D



design Takahide Sano

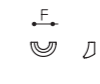

MISURA	F	L
F	32	25

Finiture_Finishes
04 / 26 / 26D / MSN

* La finitura AB è ottenuta con processi naturali, che come tali non consentono l'uniformità di colore e di tonalità fra i singoli pezzi.

The AB finish is obtained with natural elements that do not allow colour consistence from piece to piece.



* La finitura AB è ottenuta con processi naturali, che come tali non consentono l'uniformità di colore e di tonalità fra i singoli pezzi.

The AB finish is obtained with natural elements that do not allow colour consistence from piece to piece.

MANIGLIE PER MOBILI CABINET-HANDLES

2225 - 26D



design Takahide Sano

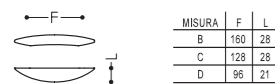

MISURA	F	L
B	160	28
C	128	28
D	96	21

Finiture_Finishes
04 / 26 / 26D / MBR / MSN

2226 - 26D



design Takahide Sano

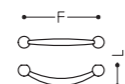

MISURA	F	L
A	192	35
B	160	35
C	128	35
D	96	35

Finiture_Finishes
04 / 26D / MSN

2231 - 26D



design Luciano Vaghi

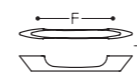

MISURA	F	L
A	192	27
B	160	27
C	128	27

Finiture_Finishes
04 / 26 / 26D / MBR / MSN

2233 - 04



design Luciano Vaghi

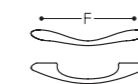

MISURA	F	L
C	128	35
D	96	35

Finiture_Finishes
04 / 26 / 26D / MBR

2227 - MSN



design Takahide Sano

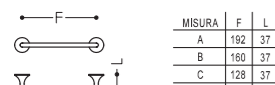

MISURA	F	L
A	192	37
B	160	37
C	128	37
D	96	37

Finiture_Finishes
04 / 26 / 26D / MBR / MSN

2228 - 26



design Takahide Sano

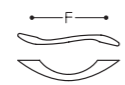

MISURA	F	L
A	192	35
B	160	35
C	128	35

Finiture_Finishes
04 / 26 / 26D / MSN

2235 - MBR



design Takahide Sano

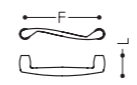

MISURA	F	L
C	128	35
D	96	35

Finiture_Finishes
04 / 26 / MBR / MSN

2237 - 26D



design Matt Johnson

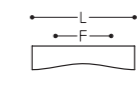

MISURA	F	L	H
C	96	178	41
D	84	141	33

Finiture_Finishes
04 / 26 / 26D / MBR / MSN

2229 - MSN



design Luciano Vaghi

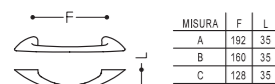

MISURA	F	L
A	192	35
B	160	35
C	128	35

Finiture_Finishes
03 / 04 / 26 / 26D / MSN

2230 - 03



design Matt Johnson



MISURA	F	L
A	192	41
B	160	41
C	128	41

Finiture_Finishes
03 / 04 / 26 / 26D / MSN

2238 - 26D



design Matt Johnson

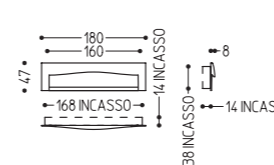

Finiture_Finishes
04 / 26D / MSN

2239 - 26D



design Studio Mandelli

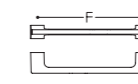

MISURA	F	L
A1	224	38
A	192	38

Finiture_Finishes
04T / 26D / MSN



Maniglia per porta con piastra
Door-handle on back-plate

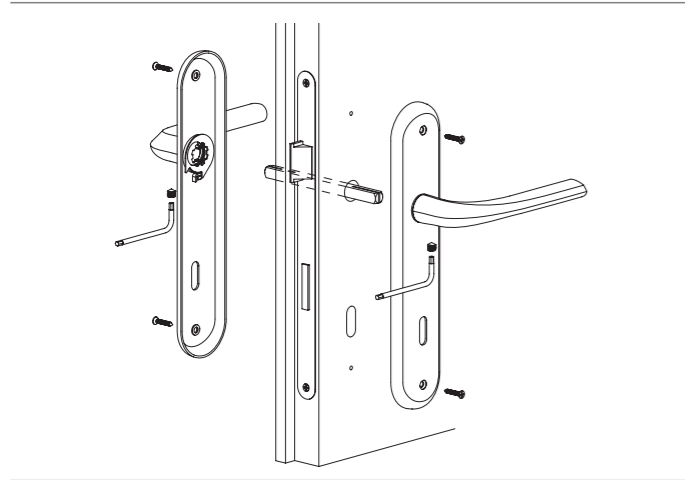

Maniglia per porta con rosetta fissaggio TG
Door-handle on rose with TG tight-through system Ø38mm

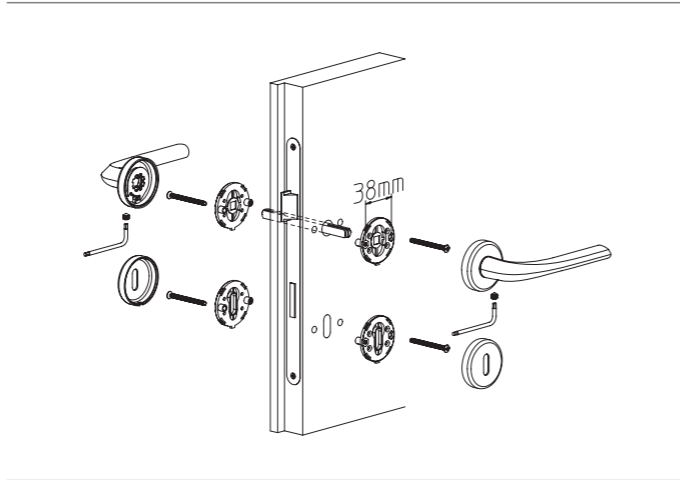

Maniglia per porta con rosetta fissaggio TS
Door-handle on rose with TS fixing system

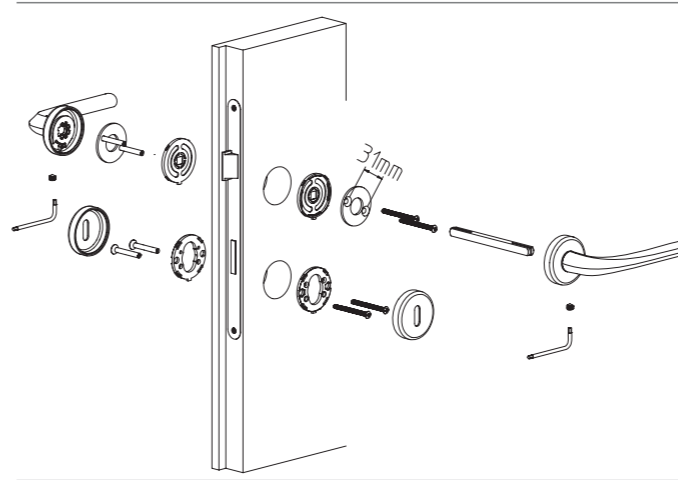

Maniglia per porta con rosetta AU PASSAGE
Door-handle on rose with AU Passage fixing system

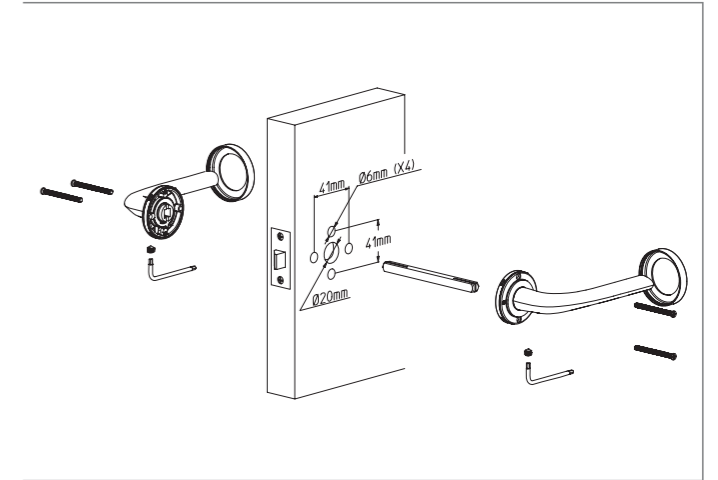

Maniglia per porta con rosetta
Door-handle on rose

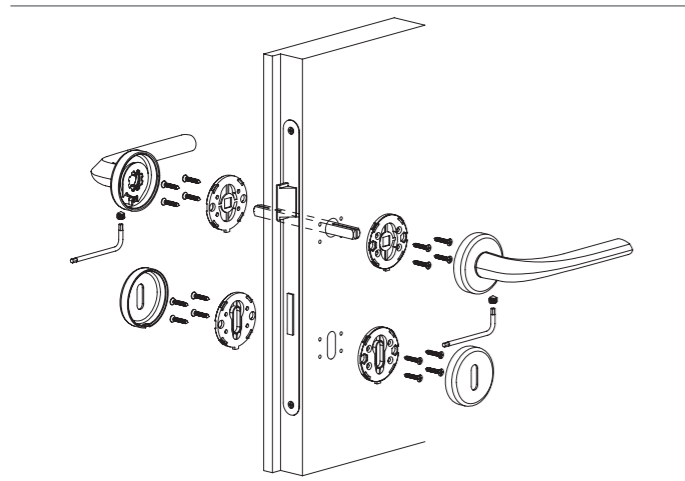

Maniglia per porta con sotto rosetta quadra fissaggio TG
Door-handle on sub-squared rose with TG tight-through system Ø38mm

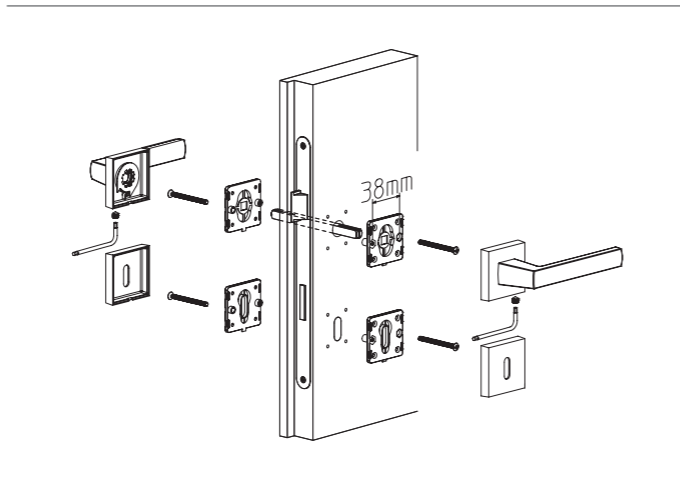

Maniglia per porta con rosetta fissaggio TS DISCO
Door-handle on rose with TS-disc fixing system

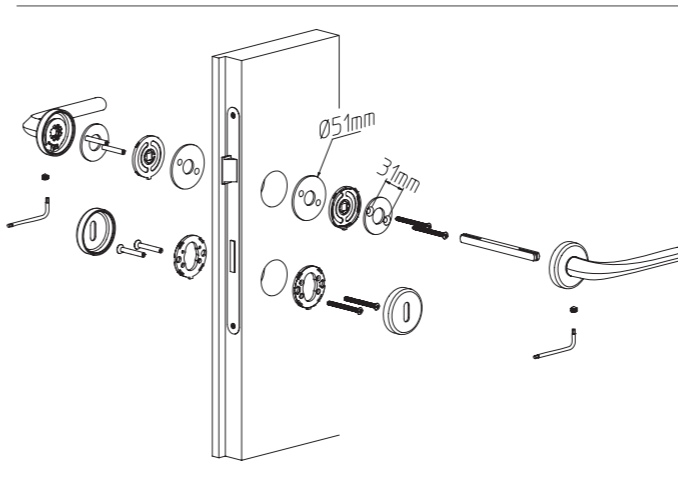

Maniglia per porta con rosetta AU PRIVACY
Door-handle on rose with AU Privacy fixing system

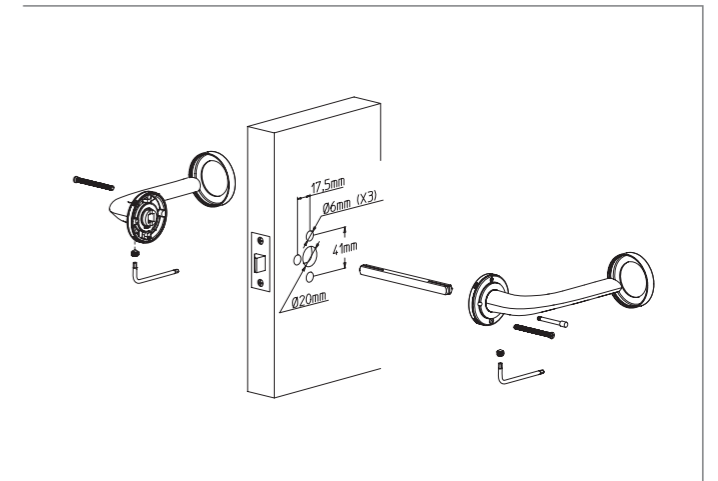

Maniglia per porta con sotto rosetta quadra
Door-handle on sub-squared rose

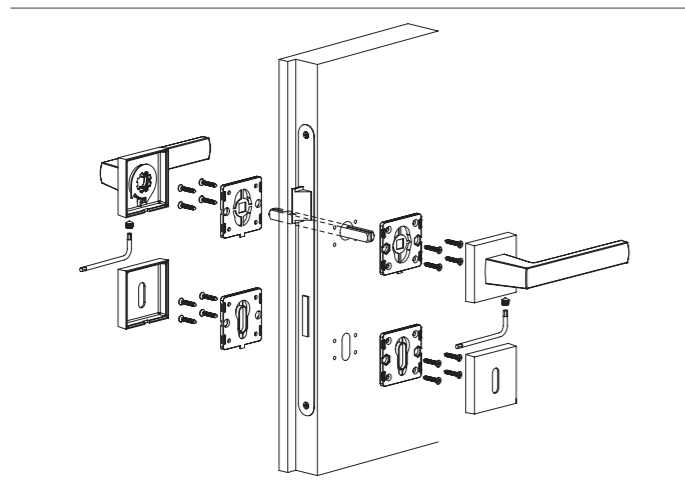

Maniglia per porta con rosetta fissaggio JP
Door-handle on rose with JP fixing system

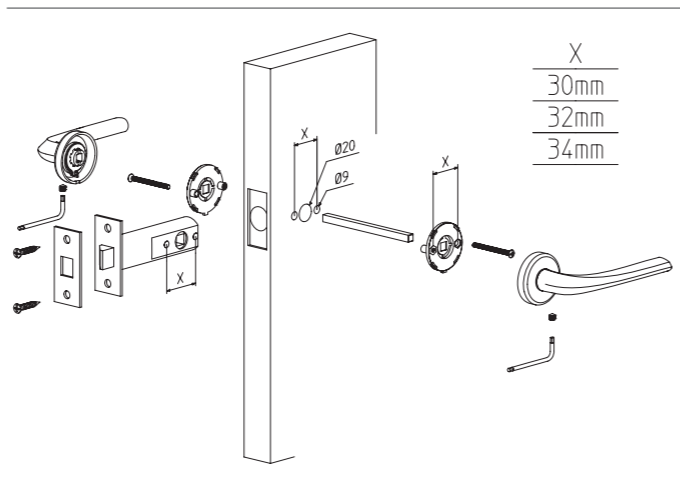

Maniglia per porta con rosetta magnetica
Door-handle on magnetic rose

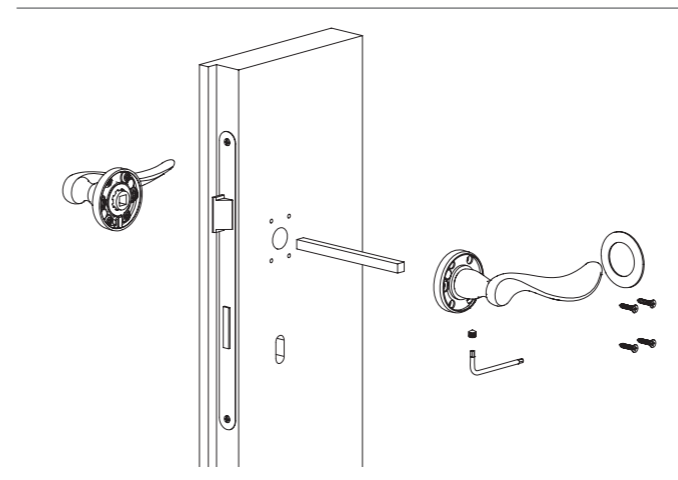

Maniglia per finestra (cremonese)
Window-handle on plate

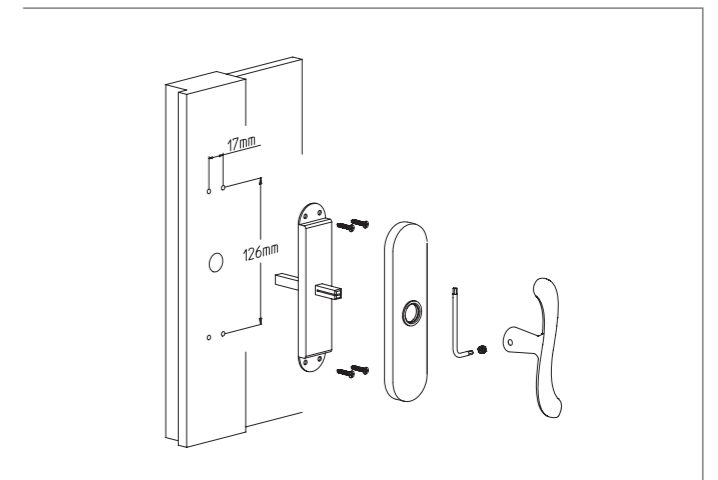

Sistemi di montaggio

Assembling schemes

Maniglia per finestra movimento DK
Drehkip window system

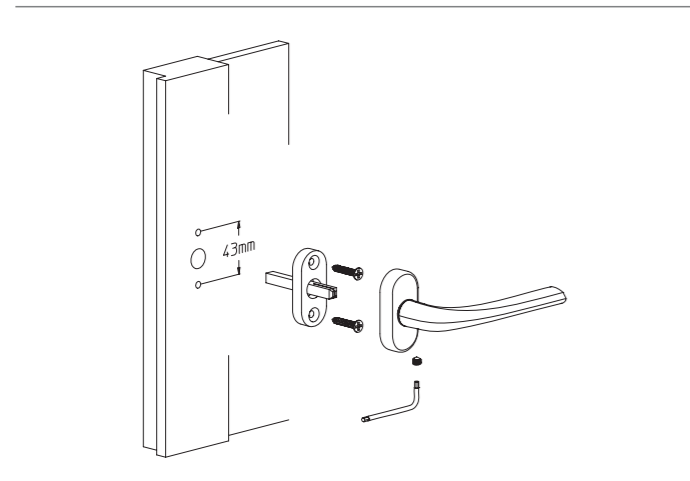

Maniglia per finestra con impugnatura maniglia
Window lever-handle

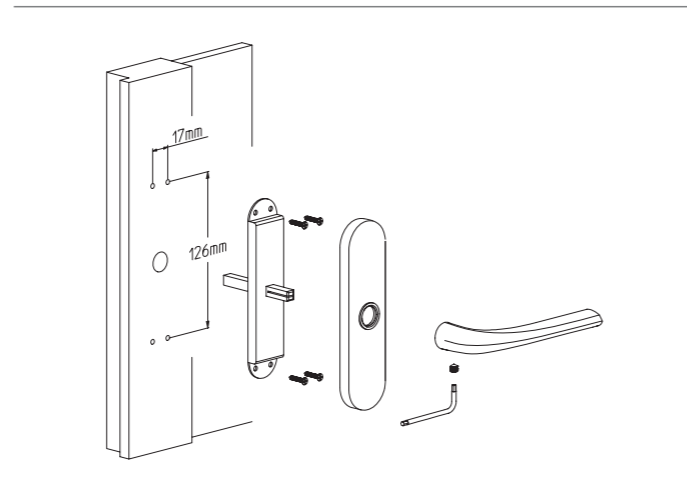

Maniglia per finestra movimento DKM magnetico brevettato
Patented magnetic DKM-lever system

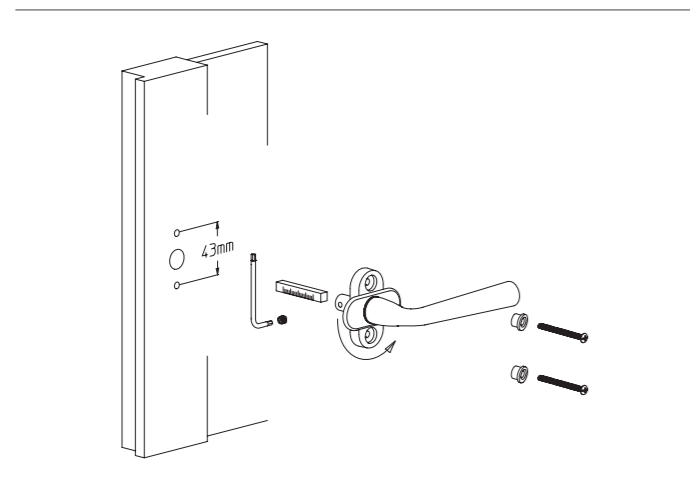

Pomolo fisso
Fix door-knob

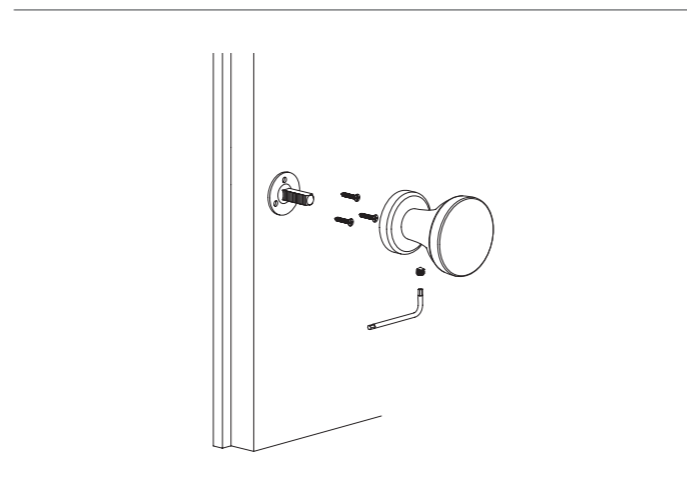

Maniglia per finestra mov. DKM-SIC magnetico di sicurezza brevettato
Patented security DKM-SIC-lever system

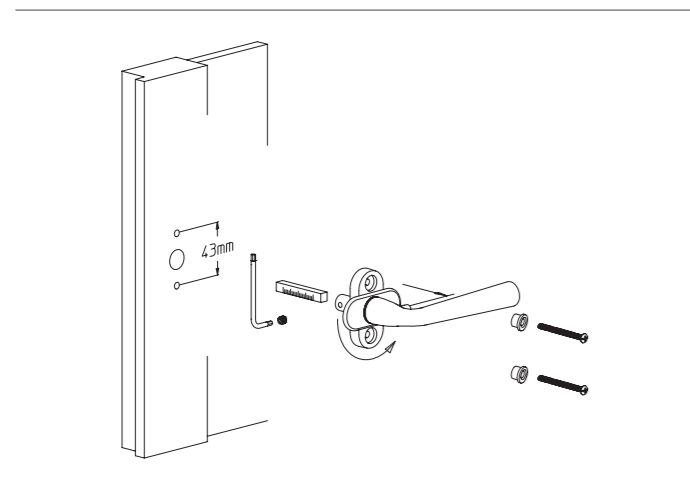

Pomolo girevole con rosetta e bocchetta
Turnable door-knob on rose with keyhole escutcheon

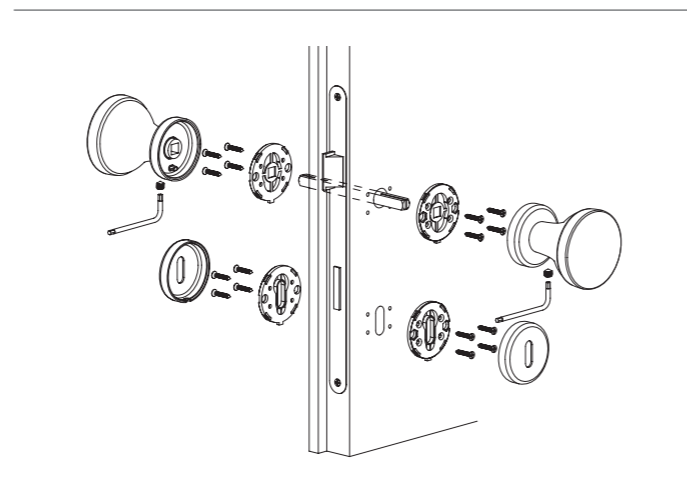

Maniglione alzante scorrevole
Patented mechanism pull-up handle for sliding door

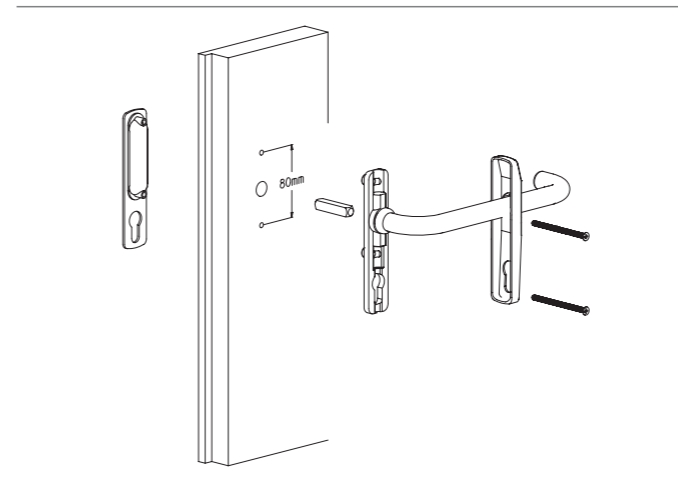

Maniglione alzante scorrevole a coppia
Patented mechanism pull-up handle pair

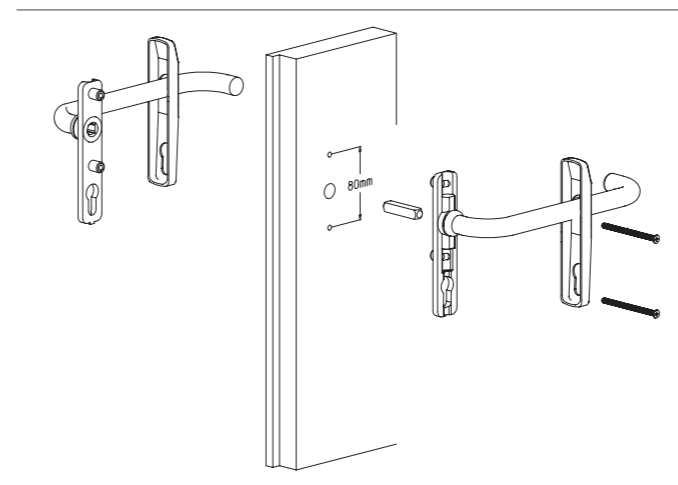

Maniglia con piastra di sicurezza ES2
Security entry set

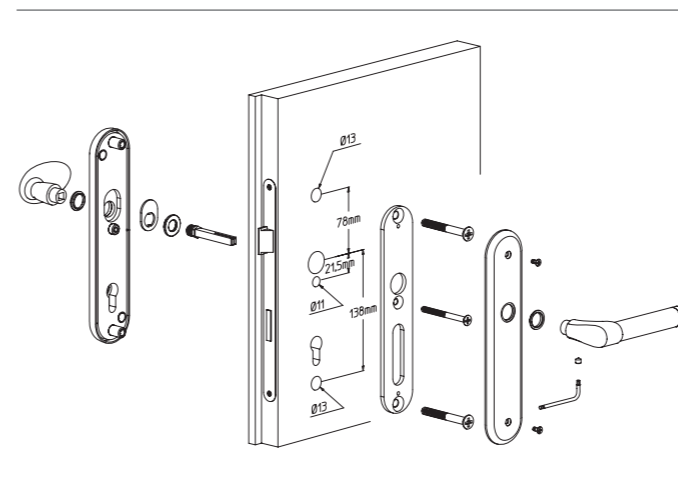

Sistemi di montaggio

Assembling schemes

Maniglia per porta scorrevole brevettata
Flush-handle kit for sliding door

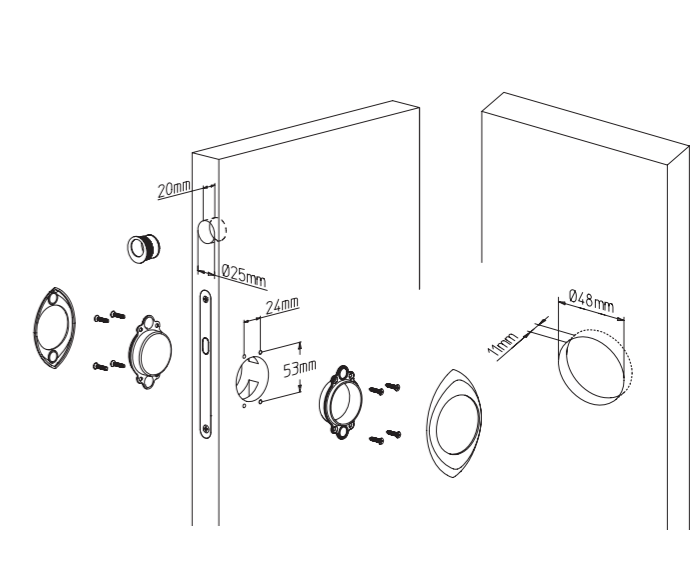
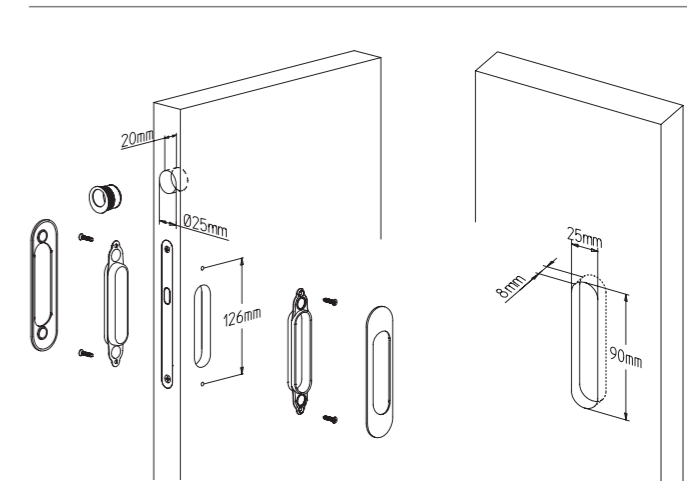

Clip ClipSlim sono brevetti Mandelli & C. spa
are a registered patent by Mandelli & C. spa

Movimenti, quadri e accessori

Devices, spindles and fittings

Tipologie prodotti

Product range

MOVIMENTI, QUADRI E ACCESSORI, SPINDLES

TIPOLOGIE PRODOTTI, PRODUCT RANGE

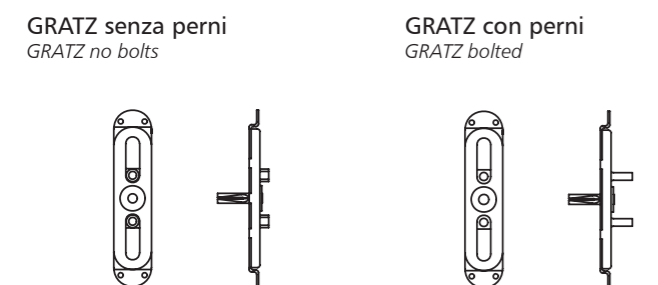

C63M313/5

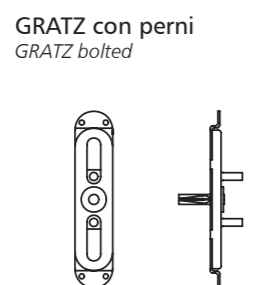

C63M314/5

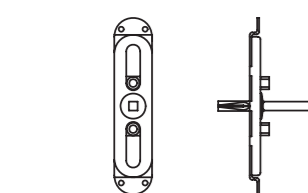

GRATZ ∇ 7 senza perni
GRATZ with 7 mm spindle,
no bolts

C63M315/5

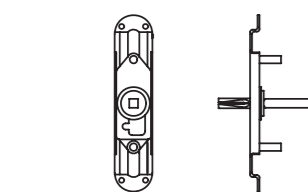

M.P. ∇ 7 mm
M.P. with 7 mm spindle

C63M316/5

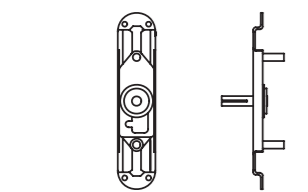

M.P.
M.P.

C63M317/5

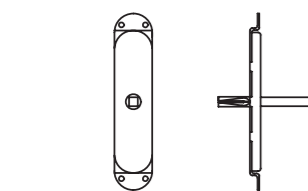

MARTELLINA ∇ 7 mm
MARTELLINA with
7 mm spindle

C63M318/5

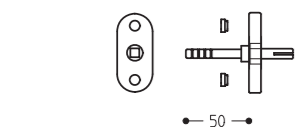

DREH-KIPP ∇ 7 mm
4 scatti
DREH-KIPP with 7 mm spindle,
4 releases

C63M319/50MOD

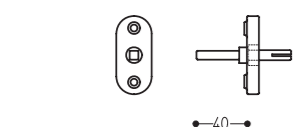

DREH-KIPP ∇ 7 mm
8 scatti
DREH-KIPP with 7 mm spindle,
8 releases

COD. C63M319/8SC

Quadro 4 PxP ∇ 8 mm
piastra tonda \varnothing 35 mm
Round 4 PxP Dummy Spindle ∇ 8 mm
dia 35 mm



C63Q35X2

Quadro 4 PxP ∇ 8 mm
4 PxP Dummy Spindle ∇ 8 mm



C63QPOM

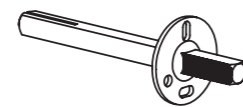

Quadro 4 PxP ∇ 8 mm x 130 mm
4 PxP Dummy Spindle ∇ 8 mm x 130 mm

q. 8 x 130 mm C63Q8X130



Quadro Standard ∇ 8 mm
Standard Spindle ∇ 8 mm

q. 8 x 100 mm C63Q8X100
q. 8 x 114 mm C63Q8X114
q. 8 x 125 mm C63Q8X125



Quadro Block ad espansione
Self Locking Spindle

q. 8 x 65 mm C63Q8X65ESP
q. 8 x 78 mm C63Q8X78ESP

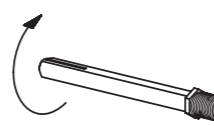

Quadro ∇ 8 mm
con passante filettato M12
Spindle ∇ 8 with threaded bolt M12

q. 8 x 85 mm C63Q8X85F12
q. 8 x 100 mm C63Q8X100F12

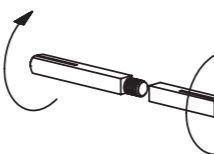

Quadro ∇ 8 mm a snodo
 ∇ 8 mm Privacy spindle

q. 8 x 95 mm C63Q8X95SNO
q. 8 x 110 mm C63Q8X110SNO

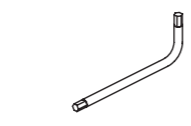

Chiave esagonale \varnothing 3 mm
Allen Wrench

C61CED3



Grani con cava esagonale
Grub Nut

M6 x 6 mm C60G6X6T
M6 x 10 mm C60G6X10T



Passante con dado
Threaded Bolt and Nut

M6 x 100 mm C63PD6X100
M8 x 150 mm C63PD8X150



Riduzioni per quadri
Spindle adapters

4 x 8 x 10 mm C63RP4X8X10
5 x 8 x 29 mm C63RP5X8X29
6 x 8 x 29 mm C63RP6X8X29
7 x 8 x 29 mm C63RP7X8X29
8 x 8,5 x 10 mm C63RP8X8.5X20

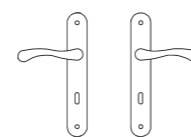

Maniglia per porta q. 6-7-8-8,5 mm
molla di ritorno incorporata,
con piastra cieca, foro normale o cilindro.

Door-handle on back plate
(dummy, standard keyhole, cylinder profile),
6-7-8-8,5 mm spindle, spring loaded.

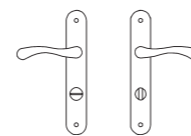

Maniglia per porta con piastra q. 6-7-8-8,5
mm, molla di ritorno incorporata, più farfalla e
voltolino q. 4-5-6-8 mm (specificare all'ordine).

Door-handle on back plate 6-7-8-8,5 mm
spindle, spring loaded, complete with turn
thumb and indicator, 4-5-6-8 mm bathr. spindle
(please specify when ordering).

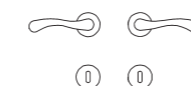

Maniglia per porta con rosetta q. 6-7-8-8,5 mm,
molla di ritorno incorporata, più bocchetta
con foro normale o cilindro, con dispositivo
di fissaggio brevettato.

Door-handle on rose 6-7-8-8,5 mm spindle,
spring loaded, complete with escutcheons
(standard or cylinder profile keyhole)
and patented fixing system.



Maniglia per porta con rosetta q. 6-7-8-8,5 mm,
molla di ritorno incorporata con dispositivo
di fissaggio brevettato, più farfalla e voltolino
q. 4-5-6-8 mm (specificare all'ordine).

Door-handle on rose 6-7-8-8,5 mm spindle,
spring loaded, patented fixing system, omplete
with turn thumb and indicator, 4-5-6-8 mm
bathr. spindle (please specify when ordering).



Maniglia per porta con rosetta q. 6-7-8-8,5 mm,
senza bocchetta molla di ritorno incorporata
con dispositivo di fissaggio brevettato.

Door-handle on rose 6-7-8-8,5 mm spindle,
no escutcheon, spring loaded,
patented fixing system.

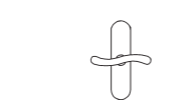

Maniglia per finestra (cremonese)
(specificare movimento).

Window-handle on plate
(please specify mechanism when ordering).

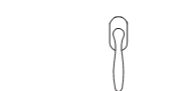

Maniglia per finestra con movimento DK
(specificare se DX o SX).

Drehkipp window-system
(please specify LH or RH when ordering).



Maniglia per finestra con movimento DKM
magnetico brevettato.

Patented magnetic DKM-lever system.



Maniglia per finestra con movimento DKM-SIC
magnetico di sicurezza brevettato.

Patented magnetic DKM-SIC-lever system.

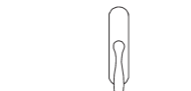

Maniglia per finestra con piastra con
impugnatura maniglia DX o SX
(cremonese - martellina).

Lever window-handle on plate
(please specify LH or RH when ordering).

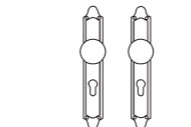

Pomolo fisso o girevole su piastra q. 6-8 mm.
(con piastra cieca, foro normale o cilindro).

Door-knob on back plate (dummy, standard
keyhole, cylinder profile) fix or turnable,
6-8 mm spindle.

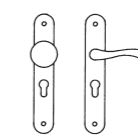

Maniglia per porta con piastra, molla di ritorno
incorporata (DX o SX) e pomolo con piastra
senza molla di ritorno (DX o SX), q. 6-7-8-8,5 mm
(con piastra cieca, foro normale o cilindro).

Door-handle on back plate, spring loaded LH
or RH and door-knob on back plate no spring
loaded, LH or RH, (dummy, standard keyhole
cylinder profile) 6-7-8-8,5 mm spindle.



Pomolo fisso per porta, q. 6-7-8-8,5 mm.
Fix door-knob, 6-7-8-8,5 mm spindle.

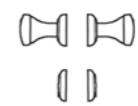

Pomolo girevole per porta q. 6-7-8-8,5 mm
completo di bocchetta, foro normale o cilindro,
dispositivo di fissaggio brevettato.

Turnable door-knob, 6-7-8-8,5 mm spindle,
complete with escutcheons (standard or cylinder
profile keyhole) Patented fixing system.



Bocchetta per porta con dispositivo di fissaggio
incorporato, con foro normale, cilindro,
ovale o tipo "Kaba".

Door-key escutcheon, standard, cylinder,
oval or "Kaba" cut-out. Patented fixing system.



Chiave per porta.
Door-key.

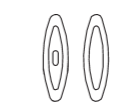

Maniglia per porta scorrevole,
con/senza foro chiave (normale, cilindro).
Flush-handle kit for sliding door with/without
standard or cylinder keyhole.

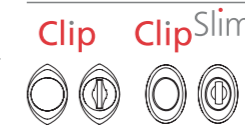

Maniglia per porta scorrevole **brevettata**,
con/senza foro chiave (normale, cilindro).
Flush-handle kit for sliding door with/without
standard or cylinder keyhole.

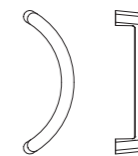

Maniglione per porta, con
sistema di fissaggio brevettato.
Door-pull complete with
patented fixing system.

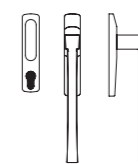

Maniglione alzante scorrevole a movimento
brevettato, completo di maniglia ad incasso
(con/senza foro normale, cilindro).
Pull-up handle for sliding doors with patented
mechanism, complete with flush-handle
(dummy, cylinder or standard keyhole).



Portabiti.
Coat-hook.

Le maniglie su piastra sono disponibili con interassi compatibili con la maggioranza degli standard mondiali. Specificare l'interasse richiesto al momento dell'ordine.
Door-handles on back plate match most world standards. Please specify centres when ordering.

Le maniglie su rosetta sono disponibili con un sistema di fissaggio adatto ai vari standard mondiali.
Door-handles on roses are delivered with a patented fixing system compatible with worldwide standards.



La società Mandelli si riserva di apportare in qualsiasi momento modifiche ai propri prodotti senza alcun preavviso. Descrizioni, foto, colori e dimensioni dei prodotti sono indicativi.

La finitura **brunito antichizzato** è ottenuta con processi naturali che non permettono l'uniformità di colore e di tonalità fra i singoli pezzi.

Le finiture **28 e 03LX** rappresentate sono puramente illustrative e possono non corrispondere esattamente alla realtà; sono ottenute con processi naturali, che come tali non consentono l'uniformità di colore e di tonalità fra i singoli pezzi.



Mandelli se reserva de aportar modificaciones a sus productos en cualquier momento sin algun aviso previo. Descripciones, fotos, colores y dimensiones de los productos son indicativas.

El acabado **bronce antiguo** es logrado con procedimientos naturales que no permiten la uniformidad de color y de tonalidad entre cada unas piezas.

El acabado **28** representado a catalogo es simplemente una imagen de ejemplo y puede que no coincida exactamente con la realidad: este acabado se realiza con unos procesos de laboraciones naturales y por lo tanto no se puede garantizar una uniformidad de color y tonalidad entre una pieza y la otra.



Technische Änderungen und Farbabweichungen vorbehalten. Produktbeschreibungen, Abbildungen, Farben und Massen nicht bindend.

Die **bruniert antik** Oberfläche ist durch natürlichen Elementen erreicht, die keine Stückuniformität garantieren können.

Aufgrund des von uns angewendeten natürlichen Herstellungprozesses kann es beim Endprodukt **Nr. 28** zu farblichen Abweichungen gegenüber dem in der Abbildung gezeigten Produkt kommen.



The Company Mandelli reserves the right to change product specifications without prior notice. Descriptions, photos, colours and product sizes are not binding.

The **antique bronze** finish is obtained with natural elements that do not allow colour consistence from piece to piece.

The **28 and 03LX** finishes are obtained with natural elements that do not allow colour consistence from piece to piece. The showed pictures are illustrative only and can be not in conformity with the real finish tone.



La société Mandelli se réserve d'apporter modifications le moment quelconque à ses produits sans aucun préavis. Descriptions, photos, couleurs et dimensions des produits sont indicatives.

La finition **bronce vielli** est obtenue par des procédés naturels qui ne permettent pas l'uniformité de couleur et de tonalité parmi les pièces.

La finition **28** ici représentée est seulement explicative et elle peut ne pas correspondre exactement à la réalité: elle est obtenue avec des procédés naturels, qui ne permettent pas l'uniformité de la couleur et de la tonalité parmi chaque pièce.



Фирма Mandelli оставляет за собой право в любой момент вносить изменения в свои изделия без всякого предварительного извещения. Описания, фотографии, цвета и размеры изделий являются указательными.

Отделка **Бронза Античная** достигается путем естественных процессов, которые не позволяют получить однородность цвета и тона между отдельными изделиями.