

A close-up photograph of a wooden workbench. In the foreground, a chisel with a wooden handle and a metal head lies on the surface. To its left, a large wooden block is being worked on, with several long, thin shavings curled around it. The background shows more wood and shavings, creating a sense of a busy workshop. The lighting is warm and focused on the tools and wood.

*Accuride*<sup>®</sup>

*Always Moving Forward*

PRECISION BALL BEARING SLIDE PRODUCTS

FOR WOOD FURNITURE  
& WOOD CABINETS

SUMMER 2013

# Accuride®

**Always Moving Forward**



Accuride International Inc. began as a small tool and die shop in 1962 in South Gate, California, producing top-quality slides for tape drives and copy machines.

In the late 1960s, Accuride developed ball bearing slides for metal office furniture. The company's design engineers then took on the wood furniture market, developing features such as breathing tabs to absorb tolerances in wood products.

Today, still privately held, Accuride has nearly one million square feet of manufacturing space around the world and is the largest company in the world dedicated to the innovative design and manufacturing of ball bearing slides. Accuride slides are designed into a wide range of applications from fine furniture and appliances, to electronic enclosures, and automotive and industrial equipment.

Accuride built its reputation on quality and ensures strict standards are met by maintaining control over many manufacturing processes others routinely job-out. Progressive dies, roll forms, and plating lines are designed, built, and maintained in house, as are other key tools and machinery.

The North American facilities feature the largest tooling operation in the industry. Globally, Accuride employs more than 100 tool and die makers, has 77 roll form machines and two in-house steel mills.

Accuride plates over 75,000,000 square feet of material per year and is the largest zinc plater in the world. Accuride was the first slide manufacturer to use the electro-coating process on ball bearing slides and has developed finishes that vigorously resist corrosion.



Accuride's test laboratory is among the largest in the industry. Products are tested to meet or exceed standards established by ANSI and other testing agencies.

Accuride was the first U.S. based slide manufacturer awarded ISO 9001 certification. Today, all our production facilities have quality management systems registered to ISO 9001:2008.



As a part of Accuride's global commitment to adhering to local environmental laws (even exceeding the standards, whenever practical), using raw materials efficiently, and reducing waste, all slide finishes and components comply with the Restriction of Hazardous Substances (RoHS) Directive.

# SLIDES FOR WOOD FURNITURE AND WOOD CABINETRY SUMMER 2013

## Technical Information \_\_\_\_\_ 2

*Slide Selection Criteria*

## Cross Section Guide \_\_\_\_\_ 4

## Light-Duty Slides \_\_\_\_\_ 8

*1029, 2632, 2132*

## Medium-Duty Slides \_\_\_\_\_ 11

*3732, Eclipse Undermount, 3832 Family,*

*3864, 7432/7434, 3017*

## Heavy-Duty Slides \_\_\_\_\_ 17

*400 Series, 3641, 3640A, 3600, 3607, 3657,*

*7950, 7957, 9301, 9307, 9308*

## Corrosion-Resistant Collection \_\_\_\_\_ 24

*SS2028, SS0330, SS5322, SS5321, AL4140, AL4120*

## Flipper Door Slides® \_\_\_\_\_ 28

*117, 1145, 1155, 123/1234,*

*1321 Pro Pocket, 1332/1432*

## Specialty Slides \_\_\_\_\_ 33

*Ascent, CB3620-258TV, 2006, 2109,*

*Keyboard Tray Systems, 2019, 2002, 0363,*

*322, 340, 301-2590, 3600-200, 3600-201,*

*115RC, CB-Hand Locking Handle Kit*

## Limited Lifetime Warranty \_\_\_\_\_ 43



Furniture by [www.diamondcase.com](http://www.diamondcase.com)



## To the reader:

This catalog is designed to assist you in making the proper slide selection for your application. The information listed in this section explains the pertinent factors to consider when selecting a slide. Products are categorized as follows:

- ◆ **Light-Duty Slides** — Load ratings up to 75 pounds. These slides are suitable for small box drawers in residential and commercial cabinetry.
- ◆ **Medium-Duty Slides** — Load ratings range from 90–100 pounds. This group is appropriate for residential cabinetry, casework, and commercial desk and credenza drawers.
- ◆ **Heavy-Duty Slides** — Load ratings from 100–500 pounds. Suitable for a wide range of applications such as wide lateral files, large storage drawers, file cabinets, and pantry pull-outs.
- ◆ **Corrosion-Resistant Collection** — Load ratings from 100–1,323 pounds. These products are made with stainless steel and aluminum to provide solutions for applications subjected to moisture.
- ◆ **Flipper Door Slides®** — Load ratings from 25–75 pounds. These slides carry doors for entertainment centers, overhead storage units, and armoires.
- ◆ **Specialty Slides** — Load ratings from 14.5–265 pounds. This group includes media hardware, slides for kitchen cutting boards, pencil drawers, pull-out and pass-through shelves, and keyboard trays.

Each section has a convenient selection guide, along with detailed descriptions for each product. For additional information, technical sheets, and specific design information, visit our web site at [www.accuride.com](http://www.accuride.com).

## DESIGN FACTORS

As with the selection of any system component, when choosing a slide for a specific application, you should consider the full range of features by comparing the project requirements to the key performance elements of the slide.

**Length**—Slide length is measured as the longest dimension of a fully closed slide. As a rule, always use the maximum length allowable in the application.

**Extension**—Or “travel”, refers to how far the drawer extends from the cabinet.

**3/4 extension** Drawer opens partially, about 3/4 of the total slide length.

**Full extension** Drawer opens the same amount as the slide length.

**Over travel** Drawer opens more than the length of the slide.

**Drawer Width**—In general, wider drawers require a slide with a higher load rating and a cross section designed to withstand lateral stress. All slide products carry a maximum recommended drawer width.

**Types of Movement**—There are generally two types of slide movement:

**Telescoping** Slide movement occurs in stages. The drawer member extends fully and then picks up the intermediate member, pulling it to the end of the travel.

**Progressive** Movement is a result of all slide members moving simultaneously. This type of movement provides extremely smooth, quiet movement.

**Disconnects**—Slides with a disconnect method allow for the removal of the drawer or drawer member. Four types of disconnects are commonly found on slides for commercial and residential applications:

**Lever** Disconnect is achieved by releasing an internal lever and pulling the drawer straight outward, away from the cabinet.

**Rail** A rail latch allows you to raise the drawer off the slide and away from the cabinet. This type of disconnect facilitates smooth movement and easy drawer removal.

**Friction** No levers or latches are required to remove the drawer. Disconnect is achieved by pulling the drawer firmly through the resistance of the ball retainer.

**Push Latch** A latch is pressed to release the drawer. Disconnect is achieved by pulling the drawer firmly through the resistance of the ball retainer.

*Note: Disconnect instructions are available online at [www.accuride.com/woodworking/resources/disconnect](http://www.accuride.com/woodworking/resources/disconnect)*

**Slide Profiles**—More than one slide profile (or height) may be appropriate for a given application. Accuride provides several low-profile design options for applications in which a smaller profile would enhance the appearance of the completed unit.

## LOAD FACTORS

---

**Load Rating**—Most Accuride slides are tested a minimum of 50,000 cycles in accordance with the guidelines of all applicable ANSI/BIFMA specifications, or as appropriate for some moderate use applications. See the product technical sheet for specific information regarding test criteria. Thorough testing means that you can count on Accuride slides to meet industry-accepted criteria.

Our slides are rated for the dynamic load that an 18" pair will carry without failure (load rating decreases proportionally beyond the 18" length). In all cases, the static (resting) load capacity of each model is at least twice the load rating, providing at minimum a 100% static safety factor, even when the slide is loaded to its maximum rating. Because slide performance may be affected by factors unique to a specific application, always test slides in the intended application.

**Flat Mounting**—For optimal slide performance, mount slides only as indicated in the catalog or on the technical sheet. Certain slides may be mounted flat under a drawer, but the resulting load rating will be at least 50% less than the load rating applicable to the same pair of slides mounted vertically on the side of the drawer. Please consult the product technical sheet for specific flat-mount load rating information.

**Shock/Vibration**—Subjecting slides to shock and vibration may adversely affect the performance. Applications that are subject to these conditions should be tested to evaluate the affect on slide performance. If conditions are severe, select a heavier-duty slide.

## APPLICATION FACTORS

---

**Unit Construction**—When installed in a drawer or cabinet that is lightweight and flexible, drawer slides can contribute to the structural rigidity of the unit. To ensure that the slide is able to provide this support, select a model with a slightly higher load rating and larger cross section than you would ordinarily need for the application.

**Installation**—Most slides are designed to be mounted in pairs on the sides of drawers or moving unit. When installing slides, exercise care to ensure that they are mounted parallel to each other, in vertical and horizontal axes.

Before mounting slides other than as designed, carefully

consider any potential adverse effects on the slide and, if necessary, consult the factory. For example, mounting slides flat under the drawer, rather than on the side, will lower the load rating by at least 50%, but mounting a slide high on one side and low on the other side will have little adverse effect on load rating. Be sure to evaluate the mounting scheme thoroughly and test as needed. Not all slide models can be used in flat-mount applications.

## ENVIRONMENTAL FACTORS

---

Unless otherwise stated, Accuride slides are designed for indoor use and should be protected from excessive moisture, chemical fumes, dirt, and corrosion. The Accuride self-cleaning ball retainer protects slide raceways by removing foreign particles between ball bearings. The lubricant provided is sufficient for normal slide life. Use care when applying finishing agents because overspray may negatively affect slide movement. Should you need to clean the slides, you can re-lubricate them with a quality grease rated "EP" for extreme pressure.

Extreme temperatures can also affect the lubricant and plastic or rubber components. Commercial drawer slides are designed to be used for extended periods in temperatures between 0 and 180 degrees Fahrenheit. For service outside normal temperature and humidity ranges, consult the factory.

## MATERIALS & FINISHES

---

**Steel Slides**—Slide members and ball retainers are made from cold-rolled steel; ball bearings are carburized steel.

**Standard Finish (C):** Clear zinc electroplate

*Optional Finishes:*

CB - Black electroplate

EW - White electrocoat

CH - Weather resistant

**Stainless Steel**—Slide members, ball retainers, and ball bearings are stainless steel.

**Aluminum**—Slide members are aluminum, ball retainers and bearings are stainless steel.

## TECHNICAL SUPPORT

---

Please visit the *Technical Resources* section on our web site at [www accuride.com](http://www accuride.com) for the most current technical information.

For further assistance, use the online *Technical Support Request* or send an e-mail to [technical@accuride.com](mailto:technical@accuride.com).

# CROSS SECTION GUIDE

LIGHT DUTY

## 1029

35 lbs.  
Max. drawer width 16"

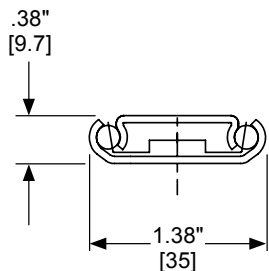

## 2632

65 lbs./pr.  
Max. dwr. width 16"

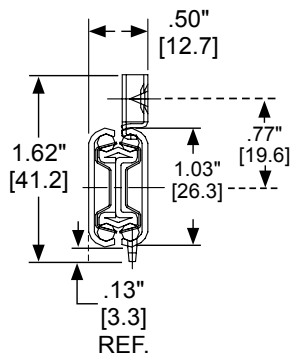

## 2132

75 lbs./pr.  
Max. dwr. width 16"

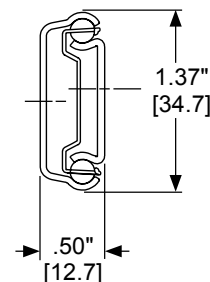

## 3732

100 lbs./pr.  
Max. dwr. width 16"

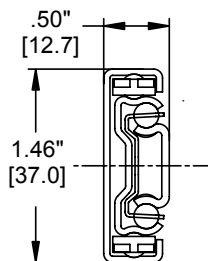

## ECLIPSE 3132

100 lbs./pr.  
Max. dwr. width 30" wide

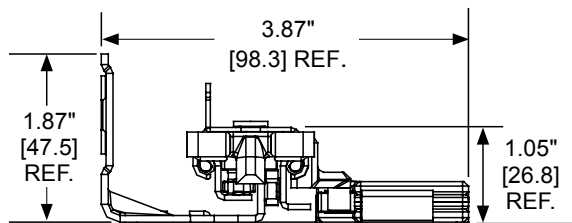

## 3832/3834

90-100 lbs./pr.  
Max. dwr. width 16"

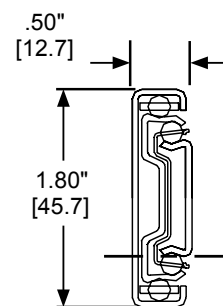

## 3864

90 lbs./pr.  
Max. dwr. width 16"

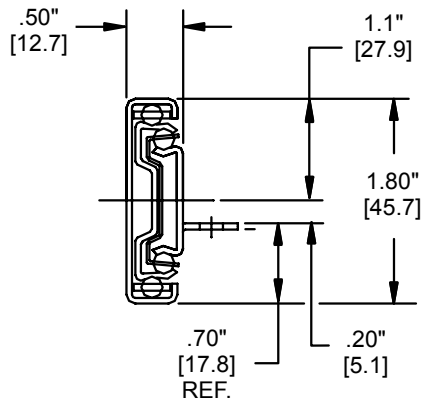

## 7432/7434

100 lbs./pr.  
Max. dwr. width 24"

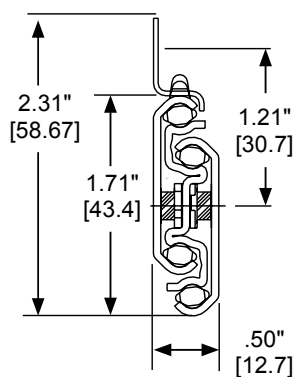

## 3017

100 lbs./pr.  
Max. dwr. width 24"

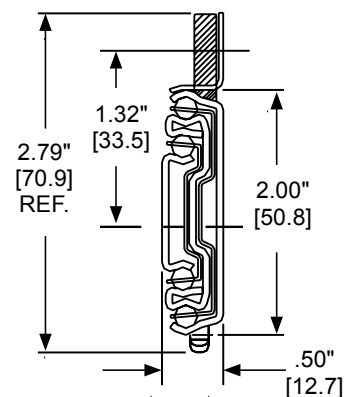

MEDIUM DUTY

### 4032/33/34/35

100-150 lbs./pr.  
Max. dwr. width:  
4032=27"; 4034=24"; 4033/35=18"

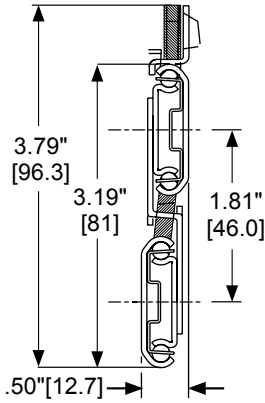

### 3641

180 lbs./pr.  
Max. dwr. width 42"

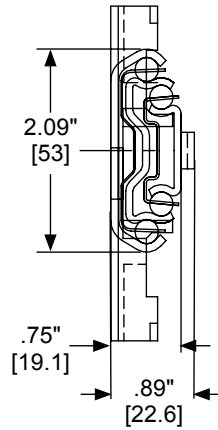

### 3640A

200 lbs./pr. side mount  
Max. dwr. width 42"  
75 lbs./pr. flat mount  
Max. dwr. width 24"

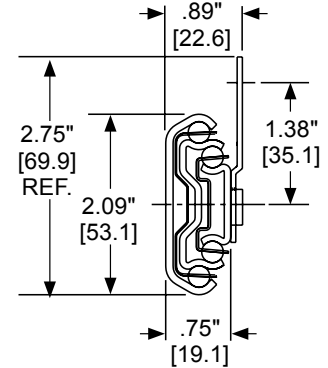

### 3600/3607/3657

200 lbs./pr.  
Max. dwr. width 42"

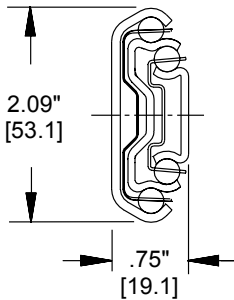

### 7950/7957

Side mount: 350 lbs./pr.  
Flat mount: 150 lbs./pr.  
Max. dwr. width 42"

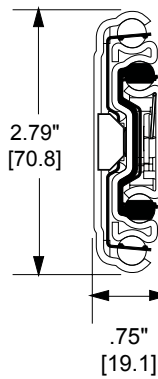
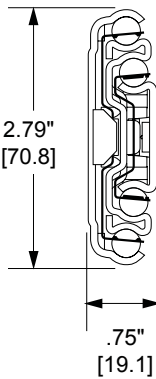

### 9301/9307/9308

150-500 lbs./pr.  
Dependent on usage

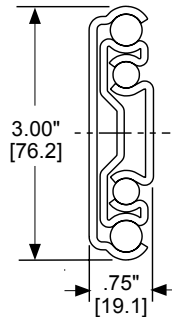

### SS2028

100 lbs./pr.  
Max. drawer width 18"

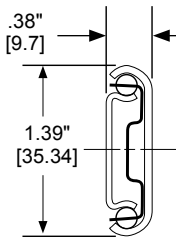

### SS0330

143 lbs./pr.  
Max. drawer width 18"

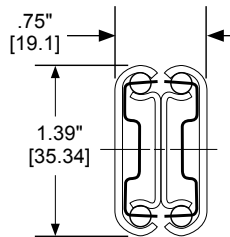

### SS5321

350 lbs./pr.  
Max. drawer width 18"

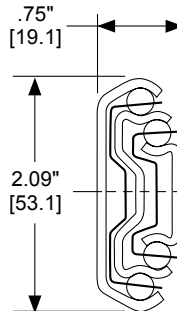

### SS5322

265 lbs./pr.  
Max. drawer width 18"

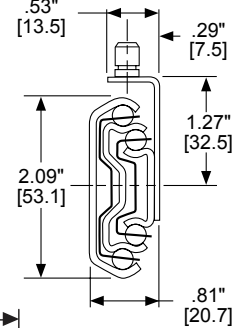

### AL4140

Up to 1,323 lbs./pr.

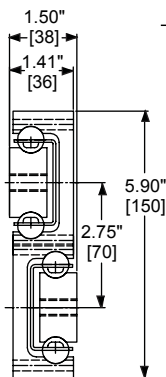

### AL4120

Up to 1,212 lbs./pr.

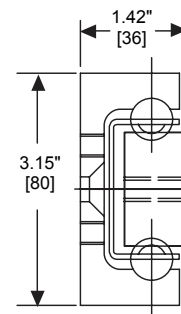

# CROSS SECTION GUIDE

FLIPPER DOOR SLIDES®

SPECIALTY SLIDES

## 117

25 lbs./pr.  
Doors up to 24" w x 36" h

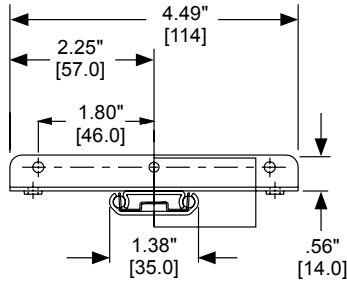

## 1145

30 lbs./pr.  
Doors up to 36" wide

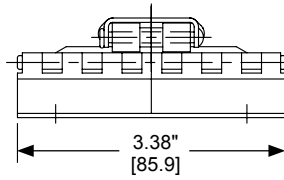

## 1155

30 lbs./pr.  
Doors up to 48" wide

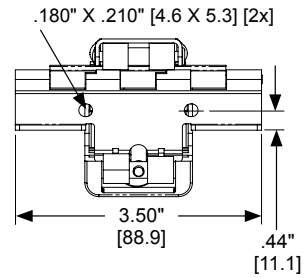

## 123/1234

30 lbs./pr.  
Doors up to 24" w x 42" h

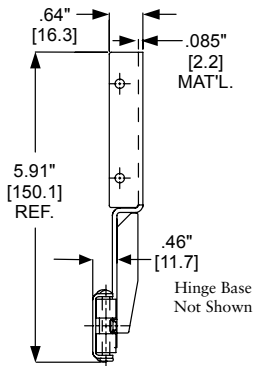

## 1321

30 lbs./pr.  
Doors up to 24" w x 42" h

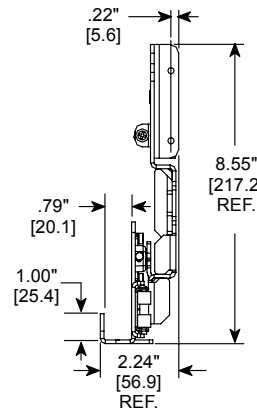

## 1332/1432

75 lbs./pr.  
Doors up to 26" w x 78" h

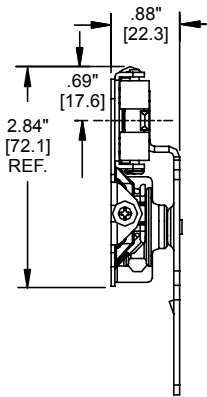

## Ascent CBLIFT-0019

Up to 14.5 lbs.

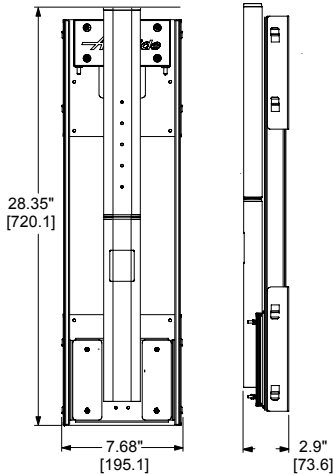

## CB3620-258TV

225 lbs.

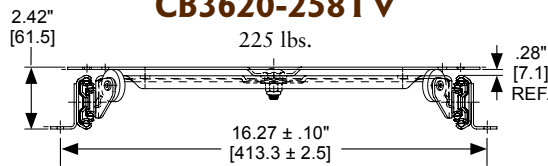

## 2006

45 lbs./pr.  
Max. dwr. width 16"

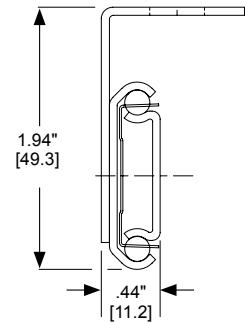

## 2109

75 lbs./pr.  
Max. dwr. width 16"

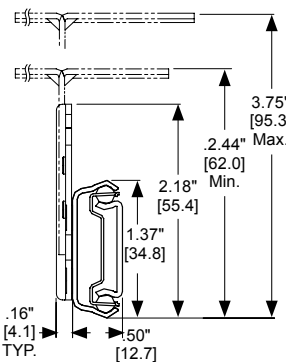

## 2019

75 lbs./pr.  
Max. dwr. width 16"

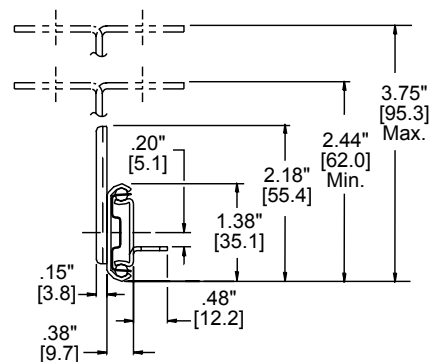



**2002**  
50 lbs./pr.  
Max. dwr. width 12"

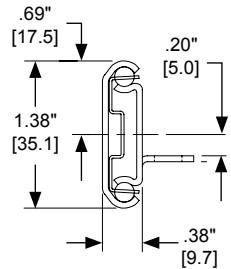

**0363**  
100 lbs./pr.  
Max. dwr. width 18"

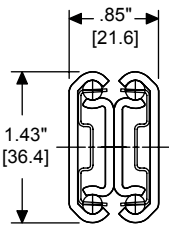

**CBERGO-TRAY200/300**

Profile width 29.6"

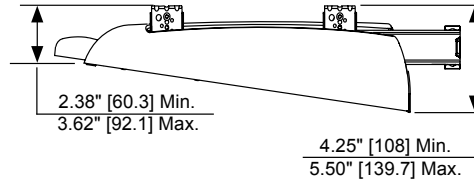

**322**  
100 lbs./pr.  
Max. dwr. width 16"

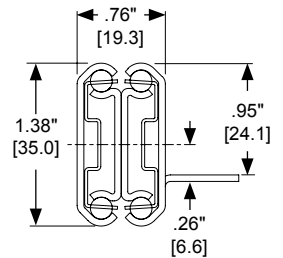

**340**  
110 lbs./pr.  
Max. dwr. width 18"

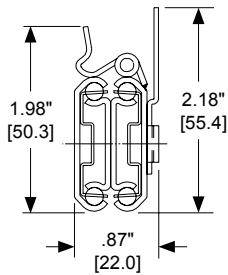

**301-2590**  
155 lbs./pr.  
Max. dwr. width 16"

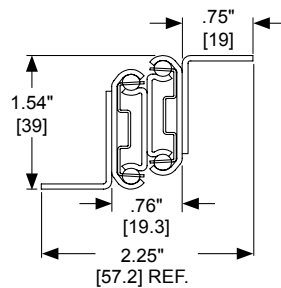

**3600-200**  
175 lbs./pr.  
Max. dwr. width 20"

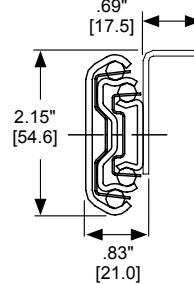

**3600-201**  
175 lbs./pr.  
Max. drawer width 20"

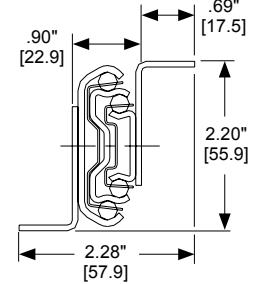

## I15RC

**LINEAR MOTION TRACK SYSTEM**  
Up to 265 lbs. [120 kg]

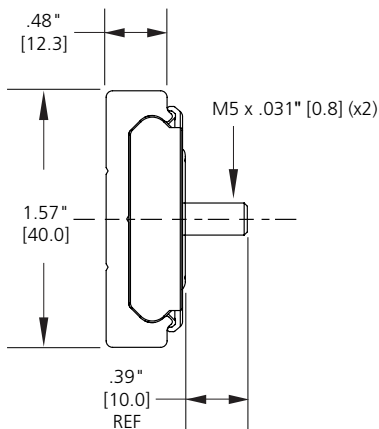

## CB-HAND - LOCKING HANDLE KITS

Max. dwr. width 60"  
Adds lock-in and lock-out to heavy-duty slides.

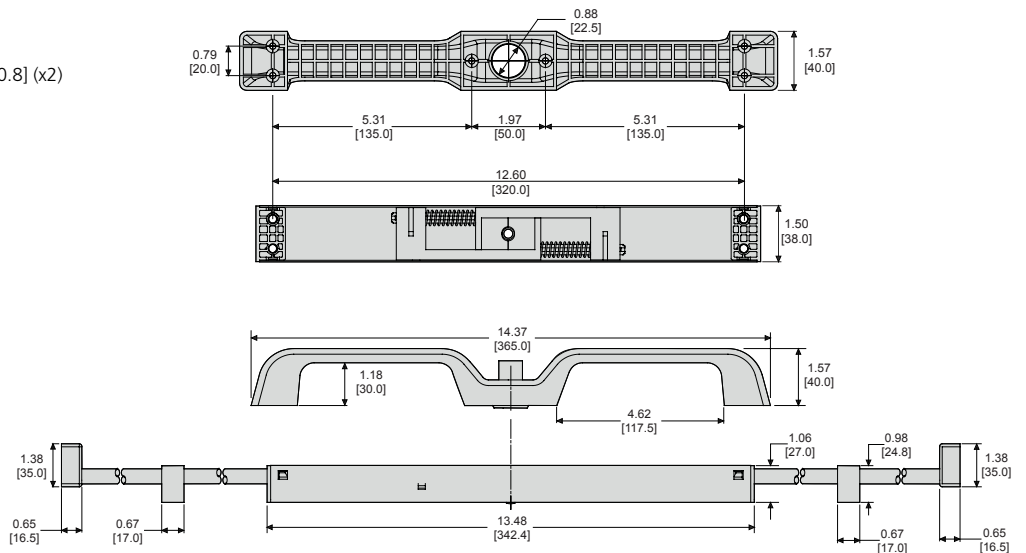

# LIGHT-DUTY SLIDES



35–75 POUNDS  
DRAWER WIDTHS UP TO 16 INCHES

MODEL	LOAD RATING	TRAVEL	DRAWER WIDTH	DETENT	DISCONNECT	PAGE
1029	35 lbs. [16 kg]	3/4	16" [406 mm]	None	Friction	9
2632	65 lbs. [30 kg]	Full	16" [406 mm]	Hold-in	Rail	9
2132	75 lbs. [34 kg]	3/4	16" [406 mm]	Hold-in	Lever	10

# 1029

35-lb. [16 kg] load rating

*A concealed undermount slide for small shallow drawers in light-duty applications.*

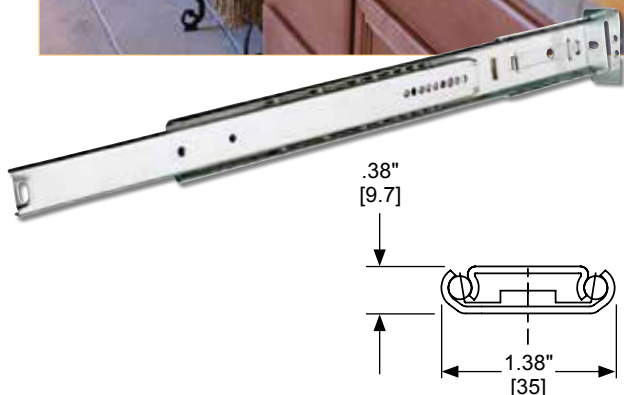

## SPECIFICATIONS

- 3/4 extension
- Drawers up to 16" [406 mm] wide
- Friction disconnect
- Steel ball bearings
- Lengths 13"-27" [330-685 mm]
- Clear zinc or black finish

## SPECIAL FEATURES

- Single slide center-mounted under drawer
- Eliminates side space requirements

**Adjustable rear mounting bracket:**  
P/N 4010-0157-CE

**Reversed rear mounting bracket:**  
P/N 4010-0353-CE



# 2632

65-lb. [30 kg] load rating

*Suitable for light-duty commercial or residential use: store fixtures, lab furniture, and kitchen box drawers.*



## SPECIFICATIONS

- Full extension
- .50" [12.7 mm] side space
- Drawers up to 16" [406 mm] wide
- Rail mount/disconnect
- Steel ball bearings
- Even lengths 8"-22" [203-559 mm]
- Clear zinc or black finish

## SPECIAL FEATURES

- Lowest profile rail mount
- Hold-in detent to prevent drawer roll-out and bounce-back
- Silenced in and out
- 32 mm and traditional hole pattern

# 2132

75-lb. [34 kg] load rating

*Use in small shallow drawers intended for office supplies or kitchen utensils in commercial or residential applications.*

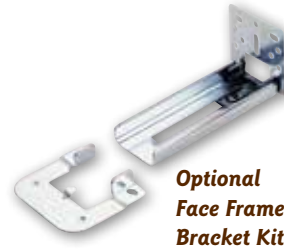

**Optional  
Face Frame  
Bracket Kit**

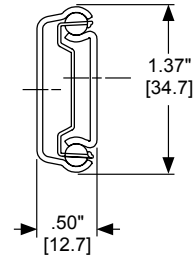

## SPECIFICATIONS

- 3/4 extension
- .50" [12.7 mm] side space
- Drawers up to 16" [406 mm] wide
- Lever disconnect
- Steel ball bearings
- Lengths 10"-28" [250-700 mm]
- Clear zinc or black finish

## SPECIAL FEATURES

- Low profile
- Hold-in detent
- Cam Drawer Adjust
- 32 mm and traditional hole pattern

**Optional face frame bracket kit:**

**P/N 4180-0321-XE**

**Pilaster mounting kit:**

**P/N 4180-0266-XE**



**90–100 POUNDS  
DRAWER WIDTHS 16–30 INCHES**

<b>MODEL</b>	<b>LOAD RATING</b>	<b>TRAVEL</b>	<b>DRAWER WIDTH</b>	<b>DETENT</b>	<b>DISCONNECT</b>	<b>PAGE</b>
3732	100 lbs. [45 kg]	Full	16" [406 mm]	Hold-in	Push latch	12
3132EC	100 lbs. [45 kg]	Full	30" [762 mm]	Hold-in	Lever	13
3832	100 lbs. [45 kg]	Full	16" [406 mm]	Hold-in	Lever	14
3864	90 lbs. [41 kg]	1" Over [25.4 mm]	16" [406 mm]	Hold-in	Lever	14
3834	90 lbs. [41 kg]	1" Over [25.4 mm]	16" [406 mm]	Hold-in	Lever	14
7432	100 lbs. [45 kg]	Full	24" [610 mm]	Hold-in	Rail	16
7434	100 lbs. [45 kg]	1" Over [25.4 mm]	24" [610 mm]	Hold-in	Rail	16
3017	100 lbs. [45 kg]	1" Over [25.4 mm]	24" [610 mm]	Hold-in	Rail	16

# 3732

100-lb. [45 kg] load rating

*This low profile slide has a convenient face frame mounting hole at the front of the slide. Ideal for kitchen, bathroom, or institutional box drawers.*



## SPECIFICATIONS

- Full extension
- .50" [12.7 mm] side space
- Drawers up to 16" [406 mm] wide
- Unhanded push latch disconnect
- Ball bearings:
  - Zinc and black finish-steel
  - White finish-steel and polymer
- Even lengths 12"-28" [305-711 mm]
- Clear zinc, white, or black finish
- Available in Production Packaging (FP)

Optional rear face frame bracket mounting kit:

P/N 4180-0431-XE

**Rear  
Face Frame  
Bracket**

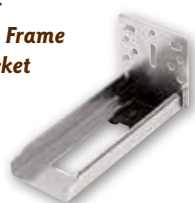

## SPECIAL FEATURES

- Lowest profile side mount slide
- Hold-in detent to prevent drawer roll-out and bounce-back
- Enhanced silencing in and out
- 32 mm and traditional hole pattern
- Front face frame mounting hole

## SAVE TIME!

**PRODUCTION PACKAGING (FP)  
AVAILABLE FOR  
ALL LENGTHS**



*Slides are shipped with the drawer members disconnected from the cabinet members. The two types of members are packaged separately within the same box, allowing the drawer members to be distributed to a different area of the shop for installation.*

**Replace  
logo with  
instead  
vec**

# 3132 Eclipse

100-lb. [45 kg] load rating

*The Eclipse undermount offers a durable concealed slide solution for both commercial and residential installations.*



## 3132EC - EASY-CLOSE

*Brings drawers to a gentle close*

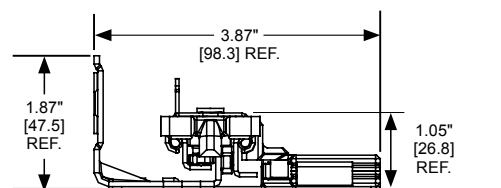
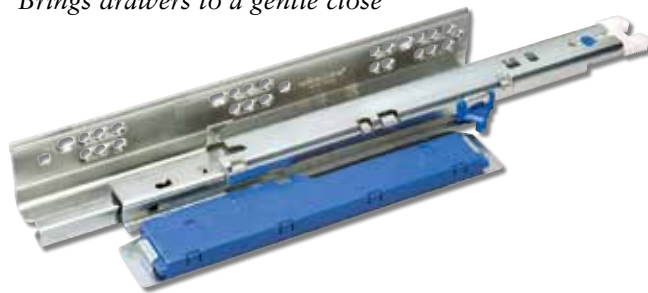

### SPECIFICATIONS

- Full extension
- Accommodates drawers up to 30" [762 mm] wide
- Front lever disconnect
- Steel and polymer ball bearings
- Even lengths 12"–28" [305–711 mm], plus 10" [254 mm], 15" [381 mm] and 21" [533 mm]
- Clear zinc finish

### SPECIAL FEATURES

- Easy-Close action brings drawers to a gentle close
- Face frame and frameless compatible
- 1/4-turn cam lock to secure drawer front position
- Vertical and horizontal cam adjustment up to 1/8"
- Slotted holes for front-to-back adjustment
- Self-adjusting drawer depth
- Optional rear face frame bracket provides 2" of depth adjustment.
- 32 mm and traditional hole pattern

### OPTIONAL KITS

**Tool kit:**

P/N 4180-0603-XE

**Drill jig:**

P/N 4180-0568-XE

**Slotted rear face frame bracket kit:**

P/N 4180-0656-XE

**Bottom mount bracket kit:**

P/N 4180-0569-XE

**Inset face frame bracket kit:**

P/N 4180-0604-XE

**Bottom Inset face frame bracket kit:**

P/N 4180-0605-XE

**Vertical mount disconnect:**

P/N 4180-0584-XE

**Standard horizontal mount:**

P/N 4180-0559-XE

**BHMA**  
with a tip  
ad of a  
tor file



# 3832 Family

90–100-lb. [41–45 kg] load rating

*This group of products offers a number of options including self-closing, detent out, weather-resistant, touch release, and easy-close.*

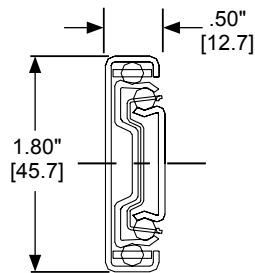
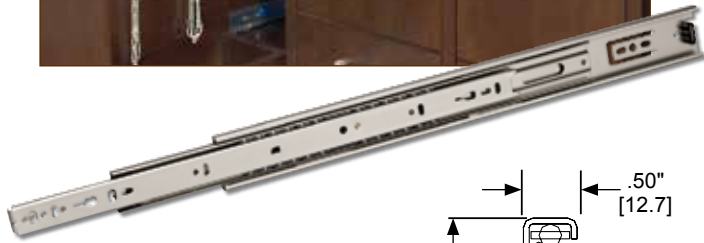

## SPECIFICATIONS

- Full extension
- .50" [12.7 mm] side space
- Drawers up to 16" [406 mm] wide
- Lever disconnect
- Ball bearings:
  - Zinc and black finish–steel
  - White finish–steel and polymer
- Clear zinc, black, or white finish\*\*

## SPECIAL FEATURES

- Hold-in detent to prevent drawer roll-out and bounce-back
- Cam Drawer Adjust
- Easy access to mounting holes
- Silenced in and out
- 32 mm and traditional hole pattern

\*\* Finish options vary by model.

3832TR eliminates the need for knobs or pulls.

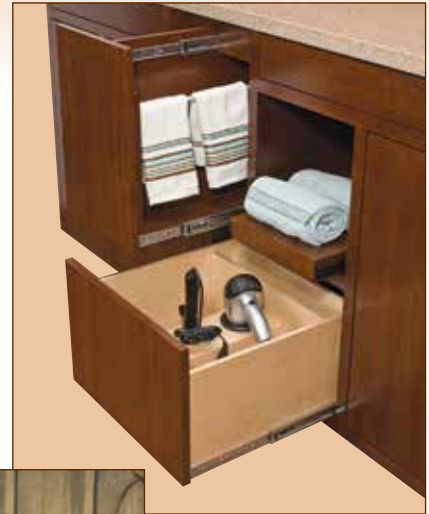

CH3832 is ideal for environments subjected to indirect humidity.

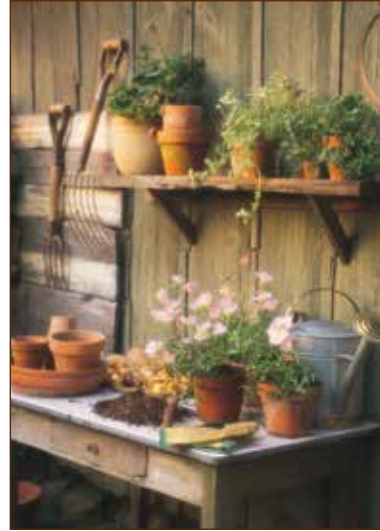

Optional accessories for pilaster and face frame mounting:

Pilaster kit:  
P/N 4180-0266-XE

Face frame kit:  
P/N 4180-0322-XE

3832TR/3832HDTR  
Face frame kit:  
P/N 4180-0661-XE

3832EC  
Face frame kit:  
P/N 4180-0305-XE



Face Frame  
Bracket Kit

## SAVE TIME!

**PRODUCTION  
PACKAGING (FP)**

**MODEL 3832  
10"–28" LENGTHS**

**MODEL 3834  
ALL LENGTHS**



*Slides are shipped with the drawer members disconnected from the cabinet members. The two types of members are packaged separately within the same box, allowing the drawer members to be distributed to a different area of the shop for installation.*



## A host of options to suit a variety of applications...



### 3832-CLASSIC

- Even lengths 6"-28" [154-700 mm]
- Lengths 10"-28" available in Production Packaging (FP)



### 3834-OVER TRAVEL

- 90-lb. [41 kg] load rating
- 1" [25.4 mm] over travel
- Even lengths 12"-28" [305-700 mm]
- Available in Production Packaging (FP)



### 3832SC-SELF-CLOSING\*

- Self-closing device ensures drawer closure
- Even lengths 12"-28" [300-700 mm]



### 3834SC-SELF-CLOSING\*

- 90-lb. [41 kg] load rating
- Self-closing device ensures drawer closure
- 1" [25.4 mm] over travel
- Even lengths 14"-28" [350-700 mm]

### 3832HDSC-HEAVY-DUTY SC\*

- Self-closing device has heavier spring for stronger hold-in action
- Even lengths 12"-28" [300-700 mm]



### 3832DO-DETENT OUT

- Special detent out to hold drawers or pull-out shelves in an open position
- Even lengths 10"-28" [199-700 mm]

### 3832TR-TOUCH RELEASE 3832HDTR-HEAVY-DUTY TR

- These products hold drawers or roll-out shelves in a closed position until activated by touch
- Even lengths 12"-28" [300-700 mm]



### CH3832-WEATHER RESISTANT

- Special coating provides eight times more protection than standard zinc finish
- Stainless steel ball retainer, ball bearings, and rivets
- Even lengths 10"-28" [199-700 mm]

### 3832EC-EASY-CLOSE\*

- Brings drawers to a gentle close
- Even lengths 14"-28" [350-705 mm]
- Not available in white finish

*Note: For optimum performance, be sure the drawer box is constructed 1-1/16" smaller than the cabinet drawer opening.*



### 3864-MOUNTING TABS

- Mounting tabs provide quick installation of drawer boxes, trays, or shelves.
- 90-lb. [41 kg] load rating
- 1" [25.4 mm] over travel
- Even lengths 12"-28" [305-711 mm]

\* Due to the self-closing feature, a stronger pull-force is required to open drawers.

# 7432/7434

100-lb. [45 kg] load rating

The top-quality choice for file, desk, and storage drawers in commercial or residential applications.

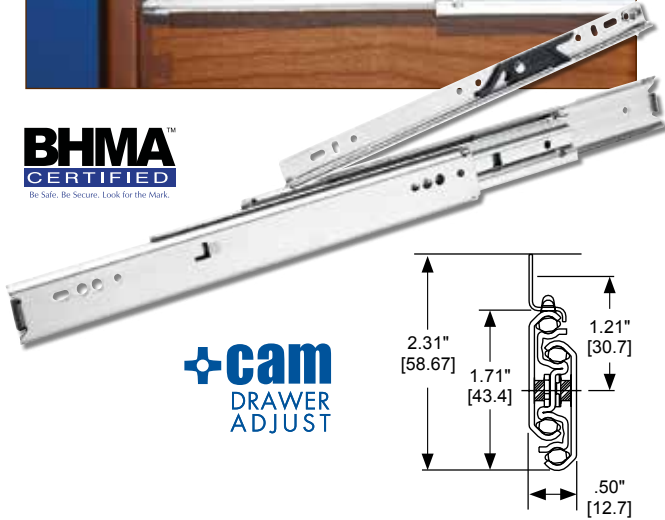

## SPECIFICATIONS

- .50" [12.7 mm] side space
- Drawers up to 24" [610 mm] wide
- Rail mount/disconnect
- Steel ball bearings
- Even lengths 12"–28" [300–700 mm]
- Clear zinc or black finish

## SPECIAL FEATURES

- Progressive movement
- Hold-in detent to prevent drawer roll-out and bounce-back
- Cam Drawer Adjust
- 32 mm and traditional hole pattern

### 7432

- Full extension

### 7434

- 1" [25.4 mm] over travel

# 3017

100-lb. [45 kg] load rating

Designed for wider desk and credenza drawers. The rail/mount disconnect and polymer ball bearings provide smooth and quiet operation.

Furniture by [www.diamondcase.com](http://www.diamondcase.com)

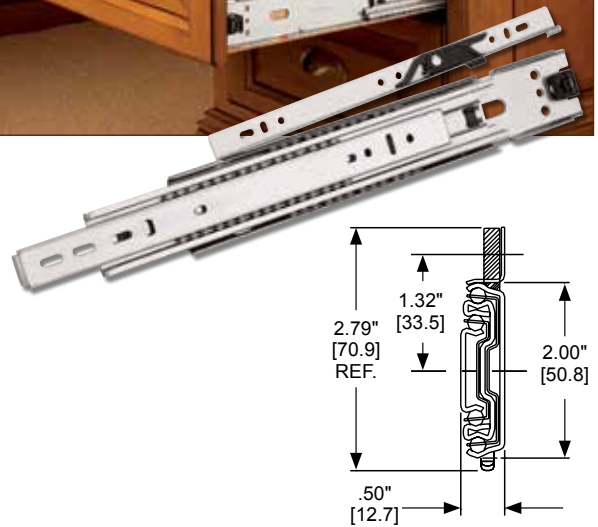

## SPECIFICATIONS

- 1" [25.4 mm] over travel
- .50" [12.7 mm] side space
- Drawers up to 24" [610 mm] wide
- Rail mount/disconnect
- Polymer ball bearings
- Hold-in detent to prevent drawer roll-out and bounce-back
- Even lengths 12"–28" [305–711 mm]
- Clear zinc or black finish



100–500 POUNDS  
DRAWER WIDTHS 18–42 INCHES



MODEL	LOAD RATING	TRAVEL	DRAWER WIDTH	DETENT	DISCONNECT	PAGE
4032	150 lb. [68 kg]	Full	27" [686 mm]	Hold-in	Rail	18
4033	100 lb. [45 kg]	Full	18" [457 mm]	Hold-in	Rail	18
4034	150 lb. [68 kg]	1.5" Over [38.1 mm]	24" [610 mm]	Hold-in	Rail	18
4035	100 lb. [45 kg]	1.5" Over [38.1 mm]	18" [457 mm]	Hold-in	Rail	18
3641 Interlock	180 lb. [82 kg]	1" Over [25.4 mm]	42" [1067 mm]	Hold-in	Rail	19
3640A	200 lb. [91 kg] Side mount 75 lb. [34 kg] Flat mount	1" Over [25.4 mm]	42" [1067 mm] 24" [610 mm]	Hold-in	Rail None	19
3600	200 lb. [91 kg]	Full	42" [1067 mm]	Hold-in	None	20
3607 Lock-out	200 lb. [91 kg]	Full	42" [1067 mm]	Hold-in	Lever	20
3657	200 lb. [91 kg]	Full	42" [1067 mm]	Hold-in	Lever	20
7950	350 lb. [159 kg]	Full	42" [1067 mm]	Hold-in	None	21
7957	350 lb. [159 kg]	Full	42" [1067 mm]	Hold-in	Lever	21
9301	150–500 lb. [227 kg] Dependent on application	Full	Up to 42" [1067 mm]		None	22
9307 Lock-out	150–500 lb. [227 kg] Dependent on application	Full	Up to 42" [1067 mm]		None	23
9308 Lock-in/out	150–500 lb. [227 kg] Dependent on application	Full	Up to 42" [1067 mm]		None	23

*Note: Super Heavy-Duty Models AL4120 and AL4140 may be found in the Corrosion-Resistant Collection on page 27.*

## 400 series

100–150-lb. [45–68 kg] load rating

*Smooth and quiet operation for deep drawers.*



Furniture by [www.diamondcase.com](http://www.diamondcase.com)

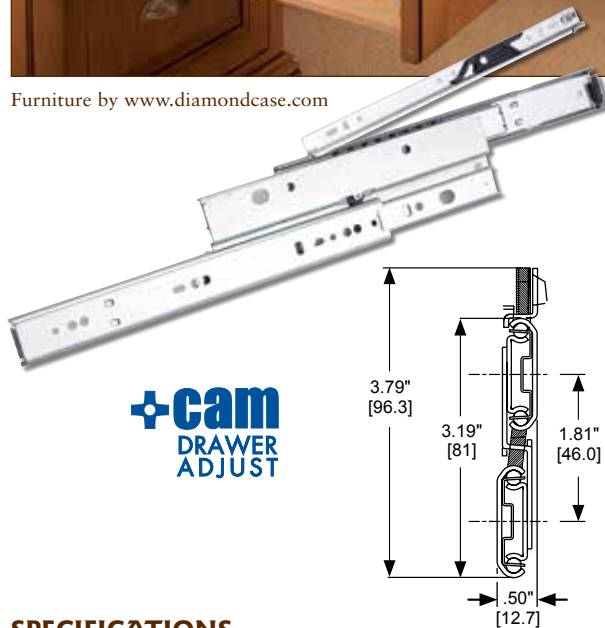

### SPECIFICATIONS

- .50" [12.7 mm] side space
- Rail mount/disconnect
- Even lengths 12"–28" [300–700 mm]
- Clear zinc or black finish

### SPECIAL FEATURES

- Progressive movement
- Hold-in detent to prevent drawer roll-out and bounce-back
- Cam Drawer Adjust
- Silenced in and out
- 32 mm and traditional hole pattern

### 4032–For wider drawers

- Drawer widths up to 27" [686 mm]
- 150-lb. [68 kg] load rating
- Full extension
- Steel ball bearings

### 4033

- Drawer widths up to 18" [457 mm]
- 100-lb. [45 kg] load rating
- Full extension
- Polymer ball bearings  
(Not recommended for lateral files)

### 4034–Over travel with a higher load

- Drawer widths up to 24" [610 mm]
- 150-lb. [68 kg] load rating
- 1.5" [38.1 mm] over travel
- Steel ball bearings

### 4035–Over travel

- Drawer widths up to 18" [457 mm]
- 100-lb. [45 kg] load rating
- 1.5" [38.1 mm] over travel
- Polymer ball bearings  
(Not recommended for lateral files)



## 3641

180-lb. [82 kg] load rating

*Suitable for commercial or residential filing cabinet drawers requiring interlock.*

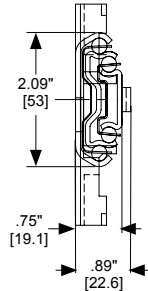

### SPECIFICATIONS

- 1" [25.4 mm] over travel
- .89" [22.6 mm] side space
- Drawers up to 42" [1067 mm] wide
- One piece rail-and-pocket mount/disconnect system
- Steel ball bearings
- Even lengths 14"-28" and 17" [353-709 and 429 mm]
- Clear zinc or black finish

### SPECIAL FEATURES

- Front location of interlock eliminates reaching during installation
- Interfaces with central locking system
- Cut-to-length aluminum connecting rods
- Hold-in detent to prevent drawer roll-out and bounce-back
- Silenced in and out
- 32 mm and traditional hole pattern

Optional gang locking system:  
P/N 4180-0345-XE

## 3640A

200-lb. [91 kg] load rating

*Can be side or flat mounted. Recommended for wider lateral file drawers.*

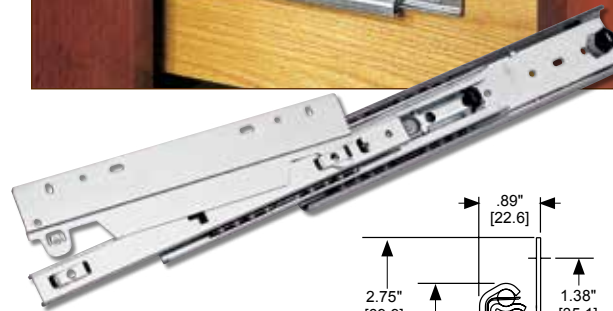

**BHMA**  
CERTIFIED  
Be Safe. Be Secure. Look for the Mark.

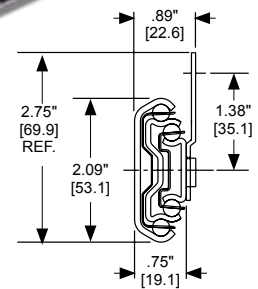

### SPECIFICATIONS

- 1" [25.4 mm] over travel
- .89" [22.6 mm] side space
- Adapter rail mount/disconnect
- Steel ball bearings
- Even lengths 12"-28" [305-711 mm]
- Clear zinc or black finish

### SPECIAL FEATURES

- Dual mounting options:
  - 200 lb. [91 kg] side mount
    - drawer width 42" [1067 mm]
  - 75 lb. [34 kg] under/flat mount
    - drawer width 24" [610 mm]
- Hold-in detent to prevent drawer roll-out and bounce-back
- 32 mm hole pattern

# 3600 Series

200-lb. [91 kg] load rating

Used for shelving units, bins, trays or wide storage drawers in commercial or residential settings.

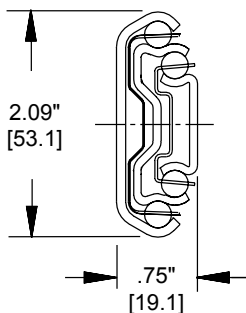

## COMMON FEATURES

- Full extension
- .75" [19.1 mm] side space
- Drawers up to 42" [1067 mm] wide
- Even lengths 12"–28" [305–711 mm]
- Clear zinc finish



### 3600

- Non-disconnect
- Hold-in detent

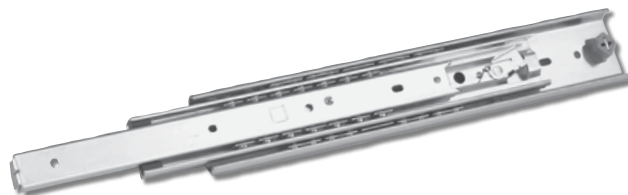

### 3607

- Lever disconnect
- Lock-out holds drawers and trays open in a safe and stable position for access



### 3657

- Lever disconnect

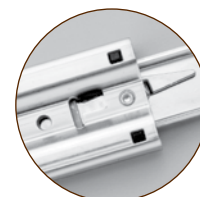

# 7950/7957

350-lb. [159 kg] load rating\*

*An intermediate load-rating choice for wide drawers in kitchens, store fixtures, or institutional storage applications.*

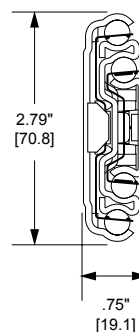

**7950**

**Non-Disconnect**

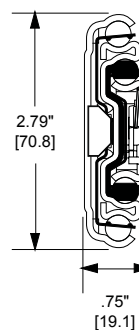

**7957**

**Handed Lever  
Disconnect**

## SPECIFICATIONS

- Full extension
- .75" [19.1 mm] side space
- 7950: non-disconnect  
7957: handed lever disconnect
- Accommodates drawers up to 42" [1067 mm] wide
- Steel ball bearings
- Even lengths 12"-36" [305-914 mm]
- Clear zinc finish

## SPECIAL FEATURES

- May be side or flat mounted:
  - Side mount load capacity up to 350 lbs. [159 kg].
  - Flat mount load capacity up to 150 lbs. [68 kg].
- Bridged ball retainer design prevents retainer migration.

\* Load rating based on a pair of 18" slides on a 42" wide drawer, cycled 10,000 times.

# 9301

150–500-lb. [68–227 kg] load rating\*

Well suited for large pantry pull-outs, vehicular storage, or other drawers with a heavier load.



**BHMA**  
CERTIFIED  
Be Safe. Be Secure. Look for the Mark.

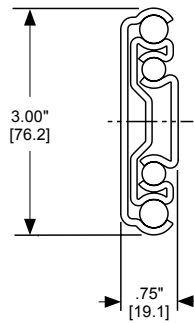

## SPECIFICATIONS

- Full extension
- .75" [19.1 mm] side space
- Non-disconnect
- Silenced in and out
- Steel ball bearings
- Includes square carriage bolt holes
- Even lengths 10"–36", 40", 42", 44", 48", and 60" [254–914, 1016, 1067, 1118, 1219, and 1524 mm]
- Clear zinc finish

## LOAD RATINGS\*

**Flat mount:** 150 lb. [68 kg]  
Drawer widths up to 32" [813 mm]

**Mobile applications:** 300 lb. [136 kg]  
Drawer widths up to 32" [813 mm]

**Frequent usage:** 400 lb. [181 kg]  
Drawer widths up to 42" [1067 mm]

**Moderate usage:** 500 lb. [227 kg]  
Drawer widths up to 18" [457 mm]

**Bracket-mounted:** 350 lb. [159 kg]  
Drawer widths up to 42" [1067 mm]

**Bracket-mounted:** 500 lb. [227 kg]  
Drawer widths up to 18" [457 mm]

## ACCESSORY PLATFORM BRACKET KITS

- Provides six additional mounting configurations
- Available in lengths of 12", 16", 22", and 28" [305, 406, 559, and 711 mm]
- Four bracket lengths have been designed to be used individually or in combination to accommodate all slide lengths.
- See technical sheet or [www accuride.com](http://www accuride.com) for bracket kit ordering information.
- Clear zinc finish

### Four Bottom-Mount Options

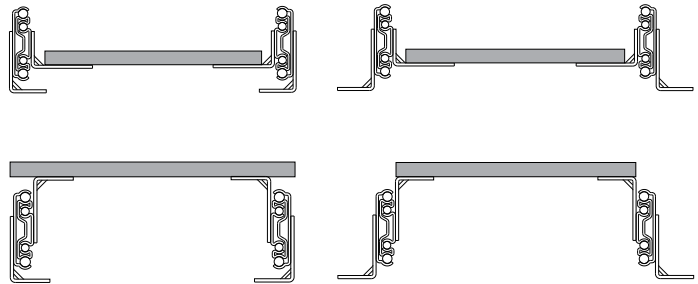

### Two Side-Mount Options

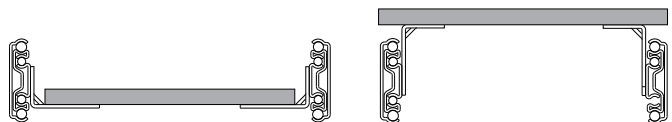

\* See product technical sheet for cycle testing data.

**Caution:** This slide must never be used as a pull-out step, platform or any other application supporting human weight, as injury may result.





Model 9308

## 9307 Lock-out

*Heavy duty with a lock-out for applications where secure access to drawers and trays adds a measure of safety.*

## 9308 Lock-in & Lock-out

*Lock-in and lock-out features to ensure drawers stay securely closed during transit in applications such as utility vehicles.*

### LOAD RATINGS

#### Mobile applications:

300 lbs. [136 kg]\*  
Drawer widths up to  
32" [813 mm]

#### Frequent usage:

400 lbs. [181 kg]\*\*  
Drawer widths up to  
42" [1067 mm]

#### Moderate usage:

500 lbs. [227 kg]\*  
Drawer widths up to  
18" [457 mm]

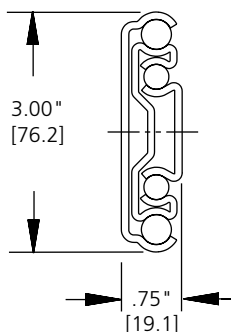

### COMMON FEATURES

- Full extension
- .75" [19.1 mm] side space
- Non-disconnect
- Lock-in/Lock-out actuated with latch at front of slide
- Compatible with optional platform brackets (see Model 9301)
- For locking on one side only, order non-locking companion slide Model 9301
- Available in even lengths 12"-36", 40", 42", 48", 60" [305-914 mm, 1016 mm, 1066 mm, 1219 mm, 1524 mm]

**Note:** Special packaging is available which includes one standard 9301 and one right-hand 9308. Available lengths: 14"-36", 40", 42", 48", and 60". The part number for this packaging is 9308-5.

\* Load ratings based on 10,000 cycle test

\*\* Load rating based on 50,000 cycle test

# CORROSION-RESISTANT COLLECTION



**100–1,323 POUNDS**  
**DRAWER WIDTHS 18–24 INCHES**

MODEL	LOAD RATING	TRAVEL WIDTH	DRAWER	DETENT	DISCONNECT	PAGE
SS2028 Stainless steel	100 lb. [45 kg]	3/4	18" [457 mm]	Hold-in	None	25
SS0330 Stainless steel	143 lbs. [65 kg]	Full	18" [457 mm]	Hold-in	None	25
SS5322 Stainless steel	265 lb. [120 kg]	Over	18" [457 mm]	Hold-in	Bracket	26
SS5321 Stainless steel	350 lb. [159 kg]	Over	18" [457 mm]	Hold-in	None	26
AL4120 Aluminum	1,212 lbs. [550 kg]	3/4	Load based on 24"	Hold-in	None	27
AL4140 Aluminum	1,323 lbs. [600 kg]	Full	Load based on 24"	Hold-in	None	27

# Stainless Steel Slides

Presenting four stainless steel products that provide corrosion-resistant solutions for installations where exposure to moisture or high humidity is a key environmental factor. These products are a great solution for drawers or pull-out shelves in outdoor kitchens, poolside structures, greenhouses, garages, sheds and barns, marine cabinetry, and more.

## SS2028

100-lb. [45 kg] load rating\*

With the narrowest side space of the group, this model provides an advantage in installations where space must be maximized.



### SPECIFICATIONS

- 3/4 extension
- .38" [9.5 mm] side space
- Drawer widths up to 18" [457 mm]
- Non-disconnect
- Stainless steel ball bearings
- Lengths 12"-28" [300-700 mm]\*\*
- Stainless steel

### SPECIAL FEATURES

- Hold-in detent
- Corrosion resistant

## SS0330

143-lb. [65 kg] load rating\*

Providing a load capacity on the lighter side of the heavy-duty category, this slide is for heavier drawers or pull-out shelves in applications that require full extension.

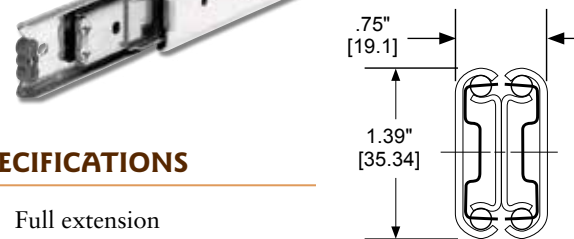

### SPECIFICATIONS

- Full extension
- .75" [19.1 mm] side space
- Drawer widths up to 18" [457 mm]
- Non-disconnect
- Stainless steel ball bearings
- Lengths 12"-24" [300-600 mm], plus 28" [700 mm]\*\*
- Stainless steel

### SPECIAL FEATURES

- Hold-in detent
- Corrosion resistant

\* Load rating based on 18" slides in 18" drawers cycled 80,000 times.  
\*\* The lengths indicated in inches are approximate conversions from the metric measurements. Please see technical sheet for exact dimensions.

## SS5322

265-lb. [120 kg] load rating\*

*The unique features on this model are over travel, for complete access to contents, and bracket mounting, which provides a disconnect method.*



### SPECIFICATIONS

- Over travel
- .81" [20.7 mm] side space
- Drawer widths up to 18" [457 mm]
- Bracket disconnect
- Stainless steel ball bearings
- Lengths 12"–24" [300–600 mm], plus 28" [700 mm] and 31" [790 mm]\*\*
- Stainless steel

### SPECIAL FEATURES

- Hold-in detent
- Corrosion resistant
- Easy-mount brackets with locator pins to simplify disconnect.

## SS5321

350-lb. [159 kg] load rating\*

*The most heavy-duty performer of the group, this slide offers a slightly narrower profile, over travel, and the greatest load rating of the collection.*



### SPECIFICATIONS

- Over travel
- .75" [19.1 mm] side space
- Drawer widths up to 18" [457 mm]
- Non-disconnect
- Stainless steel ball bearings
- Lengths 12"–24" [300–600 mm], plus 28" [700 mm] and 31" [790 mm]\*\*
- Stainless steel

### SPECIAL FEATURES

- Hold-in detent
- Corrosion resistant

\* Load rating based on 18" slides in 18" drawers cycled 80,000 times.

\*\* The lengths indicated in inches are approximate conversions from the metric measurements. Please see technical sheet for exact dimensions.

# Super Heavy-Duty Aluminum Slides

## AL4120

1,212-lb. [438 kg] load rating\*

*Super heavy duty, 3/4 extension slide in lightweight aluminum that offers corrosion resistance.*

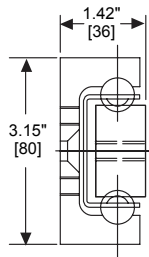
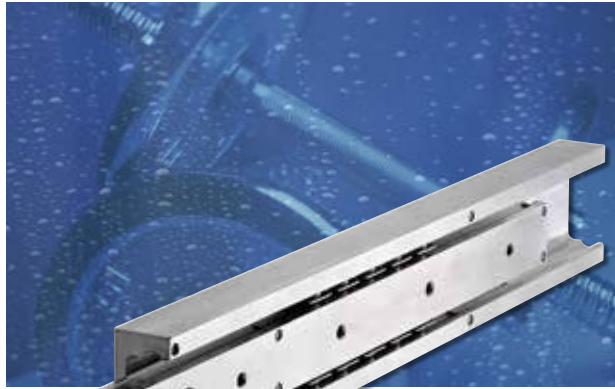

### LOAD RATINGS

- Moderate Use:  
Up to 966 lbs. [438 kg]  
*Load rating based on a pair of slides spaced 24" apart and tested to 10,000 cycles.*
- Light Use: Up to 1,212 lbs. [550 kg]  
*Load rating based on a pair of slides spaced 24" apart and tested to 5,000 cycles.*

### SPECIFICATIONS

- 3/4 extension
- 1.42" [36 mm] side space
- Non-disconnect
- Stainless steel ball bearings
- Lengths: 16", 20", 24", 28", 32", 36", 40", 44", and 48" [400, 500, 600, 700, 800, 900, 1000, 1100, and 1200 mm]\*

### SPECIAL FEATURES

- Manufactured with lightweight aluminum, with stainless steel ball bearings and ball retainers to provide corrosion resistance and strength without the additional weight of steel slides.

## AL4140

1,323-lb. [600 kg] load rating\*

*Super heavy duty, with full extension in lightweight aluminum that offers corrosion resistance.*

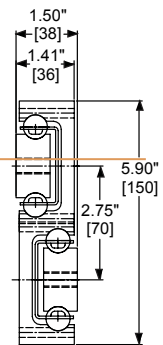
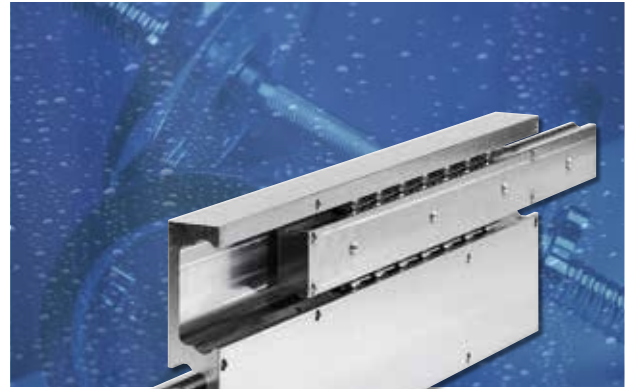

### LOAD RATINGS

- Moderate Use:  
Up to 882 lbs. [400 kg]  
*Load rating based on a pair of slides spaced 24" apart and tested to 10,000 cycles.*
- Light Use: Up to 1,323 lbs. [600 kg]  
*Load rating based on a pair of slides spaced 24" apart and tested to 5,000 cycles.*

### SPECIFICATIONS

- Full extension
- 1.5" [38 mm] side space
- Non-disconnect
- Stainless steel ball bearings
- Lengths: 16", 20", 24", 28", 32", 36", 40", 44", and 48" [400, 500, 600, 700, 800, 900, 1000, 1100, and 1200 mm]\*

### SPECIAL FEATURES

- Manufactured with lightweight aluminum, with stainless steel ball bearings and ball retainers to provide corrosion resistance and strength without the additional weight of steel slides.

\*\* The lengths indicated in inches are approximate conversions from the metric measurements. Please see technical sheet for exact dimensions.

# FLIPPER DOOR SLIDES®



25–75 POUNDS

MODEL	MAXIMUM DOOR WEIGHT	MOUNTING	MAXIMUM DOOR SIZE	PAGE
117	25 lbs. [11 kg]	Horizontal or Vertical	24"w x 36"h [610 mm x 914 mm]	29
1145 Over-the-top	30 lbs. [14 kg]	Horizontal	Up to 36" wide [914 mm]	29
1155 Easy-Down®	30 lbs. [14 kg]	Horizontal	Up to 48" wide [1219 mm]	30
123/1234	30 lbs. [14 kg]	Horizontal or Vertical	24"w x 42"h [610 mm x 1067 mm]	30
1321 Pro Pocket	30 lbs. [14 kg]	Vertical	24"w x 42"h [610 mm x 1067 mm]	31
1332/1432 Anti-Rak cable	75 lbs. [34 kg]	Vertical	26"w x 78"h [660 mm x 1981 mm]	32

# 117

25-lb. [11 kg] load rating

*Suitable for entertainment cabinets and office storage doors.*

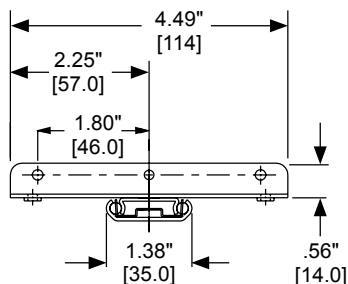
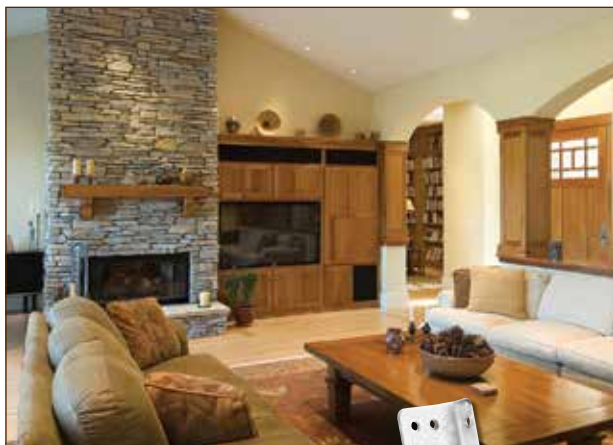

## SPECIFICATIONS

- Doors up to 24" w x 36" h [610 mm x 914 mm]
- Steel ball bearings
- Even lengths 12"-28" [305-711 mm]
- Clear zinc or black finish

## SPECIAL FEATURES

- Optional detent-out feature prevents door sag
- No partition required
- Silenced in and out

Horizontal mounting requires pivot roller kit:  
P/N 4180-0302-XE

# 1145

30-lb. [14 kg] load rating

*Medium duty for armoires, storage cabinets, and entertainment center doors.*

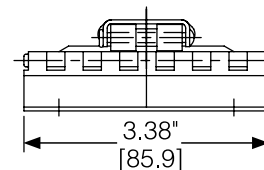

## SPECIFICATIONS

- 36" [914 mm] maximum door width
- Steel and polymer ball bearings
- Lengths 10"-24" [252-608 mm]
- Clear zinc or black finish

## SPECIAL FEATURES

- Minimum door racking
- Pin hinge included

Mounting bracket kit (zinc):  
P/N 4180-0325-XE

Mounting bracket kit (black):  
P/N 4180-0326-XE

# I 155 Easy-Down®

30-lb. [14 kg] load rating

*The Easy-Down® has a motion control system to ensure overhead doors close safely.*

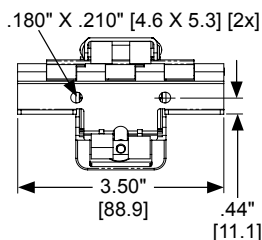

## SPECIFICATIONS

- Accommodates door widths up to 48" [1219 mm]
- Steel ball bearings
- Even lengths 12"–24" [303–608 mm]
- Clear zinc or black finish

## SPECIAL FEATURES

- Over-the-top design provides no loss of normal storage space
- Protects user from rapid drop of door
- Door closing speed remains similar on both light and heavy doors
- Easy installation—requires few or no cabinet modifications
- Cylinder cover cap provides a finished look (not shown)

Mounting bracket kit (zinc):  
P/N 4180-0325-XE

Mounting bracket kit (black):  
P/N 4180-0326-XE

*The cylinder for the Easy-Down® is covered by a five year limited warranty.*

# I 23/I 234

30-lb. [14 kg] load rating

*Accommodates taller kitchen cabinet and entertainment center doors.*

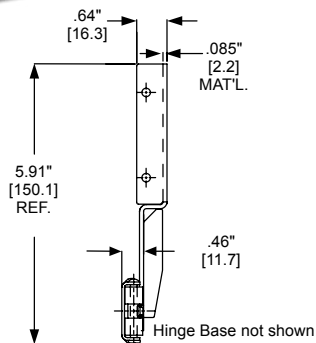

## SPECIFICATIONS

- Doors up to 24" [610 mm] wide by 42" [1067 mm] tall
- Hold-out detent
- Steel ball bearings
- Even lengths 12"–28" [305–711 mm]

**I 23**—35 mm inset hinges included  
Black zinc finish—slides and hinges

**I 234**—Hinges purchased separately  
Black zinc finish—slides only

## OPTIONAL HINGE KITS

35 mm hinge:  
P/N 4180-0391-XE

Overlay (40 mm):  
P/N 4180-0314-XE

Thick door (40 mm):  
P/N 4180-0313-XE



# I321 Pro Pocket

30-lb. [14 kg] load rating

*The Pro Pocket is a full 3/4-inch overlay Flipper Door Slide® with special features that virtually eliminate door damage.*



## MODEL I321

Full 3/4" Overlay  
Flipper Door Slide®

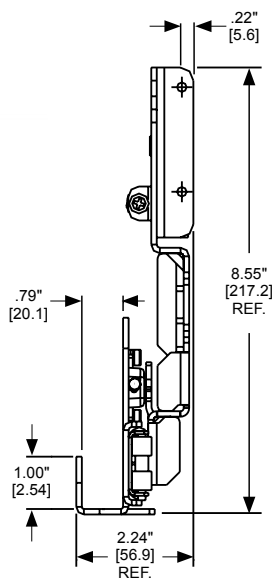

### SPECIFICATIONS

- Doors up to 42" [1067 mm] tall by 24" [610 mm] wide
- Steel ball bearings
- Even lengths 16"-28" [405-710 mm]
- Black electroplate finish

### SPECIAL FEATURES

- Attached brackets provide easy partition installation and removal
- Auto-open feature pushes cabinet doors open the last 1-1/4" [32 mm] of travel to ensure doors are fully extended
- Skid blocks with indexing marks ease installation, and protect door face, top, and bottom
- Cover caps provide aesthetic finish

# 1332/1432 Anti-Rak Cable System

75-lb. [34 kg] load rating

*These slides are designed for taller, heavier doors used on armoires, or audiovisual and home entertainment cabinetry.*

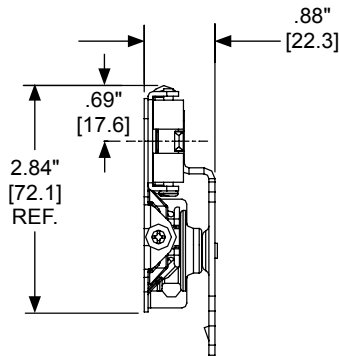
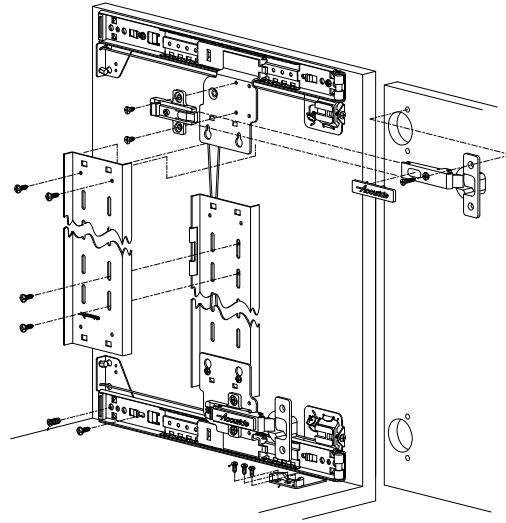

## SPECIFICATIONS

- Door heights up to 78" [1981 mm]
- Door widths to 26" [660 mm]
- For doors 36"–78" [914–1981 mm] tall additional hinges required—see below
- Lengths 12"–32" [303–813 mm]
- Hold-out detent
- Silenced in and out
- Steel ball bearings
- Standard black or optional clear zinc finish

**1332**—35 mm inset hinges included

**1432**—Hinges purchased separately

### Extra Hinge Kit (35 mm inset):

P/N 4180-0407-XE

Black finish

P/N 4180-0389-XE

Zinc finish

### Hinge Carrier Strip Kit:

*(required for doors 36"–78" tall [914–1981 mm])*

P/N 4180-0408-XE

Black finish

P/N 4180-0410-XE

Zinc finish

Connector Clip Kit (to join carrier strips)

P/N 4180-0412-XE

### Optional 40 mm hinge kits:

P/N 4180-0292-XE

7/16" overlay for doors up to 3/4" [19.1 mm]

P/N 4180-0394-XE

Thick doors up to 1-1/4" [31.8 mm]



Photo courtesy JOI-Design Innenarchitekten GmbH & Hilton Hotel Group

## 14.5–265 POUNDS

MODEL	LOAD RATING	TRAVEL	DESCRIPTION				PAGE
CBLift-0019 Ascent	14.5 lbs. [6.6 kg]	22"	Push-to-operate mechanical lift for screens up to 17.5" tall and 22" diagonally.				34
CB3620-258TV TV Swivel	225 lbs. [102 kg]	N/A	Accuride's TV Swivel handles televisions up to 36" diagonally.				34
MODEL	LOAD RATING	TRAVEL	DRAWER WIDTH	DETENT	DISCONNECT	PAGE	
2006 - Pencil drawer slide	45 lb. [20 kg]	3/4	16" [406 mm]	None	Friction	35	
2109 - Suspended drawer slide	75 lb. [34 kg]	3/4	16" [406 mm]	Hold-in and -out	Lever	35	
CBERGO-TRAY 200 CBERGO-TRAY 300 - Deluxe	-	3/4 Full	29.6" [751 mm]	Hold-in & -out Hold-in, -out, & intermed.		36	
2019 - Suspended-shelf slide	75 lb. [34 kg]	3/4	16" [406 mm]	Hold-out	Lever	37	
2002 - Two-way travel slide	50 lb. [23 kg]	3/4	12" [305 mm]	Center	None	37	
0363 - Two-way travel slide	100 lb. [45 kg]	Full	18" [457 mm]	Center	None	38	
322 - Pull-out shelf	100 lb. [45 kg]	.88" Over [22 mm]	16" [406 mm]	None	None	39	
340 - Butcher block slide	110 lb. [50 kg]	Full	18" [457 mm]	None	Bracket	39	
301-2590 Pull-out storage slide	155 lb. [70 kg]	.83" Over [21 mm]	16" [406 mm]	Hold-in	None	40	
3600-200/3600-201 StowAway slides	175 lb. [79 kg]	Full	20" [508 mm]	None	Lever	40	
115RC Linear Motion Track System	265 lb. [120 kg]	Unlimited	-	-	-	41	
CB-HAND Locking Handle Kit	Dependent on slide	N/A	Up to 60" [1.5 m]	None	-	42	

# CBLift-0019

## Ascent

14.5-lb. [6.6 kg] load rating

The Ascent is a push-to-operate mechanical lift that provides access and conceals screens in desks and other cabinetry.

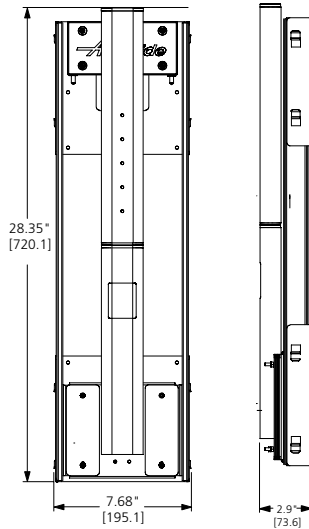

### SPECIFICATIONS

- Accommodates screens from 5.5–14.5 pounds [2.5–6.6 kg], up to 17.5" tall, and 22" diagonally
- No power required; movement is controlled by counterbalancing weights
- Swivels  $\pm 112.5^\circ$  for expanded viewing access
- Black electroplate finish

### SPECIAL FEATURES

- Easy to install
- Unit raises 21 inches in less than 2 seconds

### OPTIONAL KITS

Additional Weight Pack  
P/N 2990-9774-BE

VESA 18° Tilt Bracket  
P/N 2990-9776-BE

Weight Extension Plate Kit  
P/N 2990-9775-BE

VESA Fixed Bracket  
P/N 2990-9777-BE

Note: Packaging includes wire management, cable control kit, and one weight pack.

# CB3620-258TV

225-lb. [102 kg] load rating\*

A smooth pull-out swivel that holds televisions up to 36" diagonally.

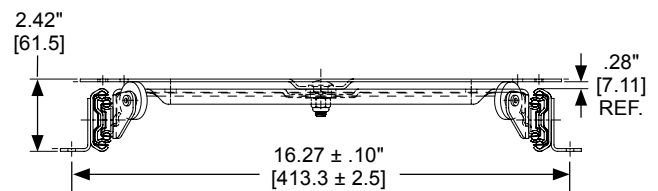

### SPECIFICATIONS

- 14" [356 mm] extension
- Holds televisions up to 36" [914 mm] diagonally
- Steel ball bearings
- Black zinc plating

### SPECIAL FEATURES

- Hold-in detent to prevent roll-out and bounce-back
- Smooth, stable movement
- 360° swivel
- Silenced in and out

\* Load rating based on 10,000 cycle test.

# 2006

45-lb. [20 kg] load rating

*Known as the pencil drawer slide, this product is designed for suspended drawers beneath desks or tabletops.*

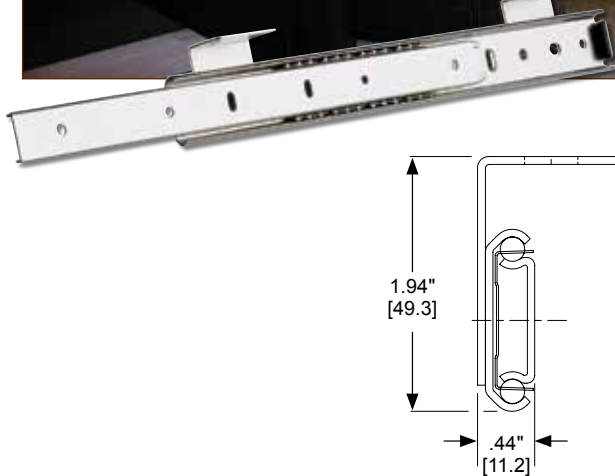

## SPECIFICATIONS

- 3/4 extension
- .44" [11.2 mm] side space
- Drawer widths up to 16" [406 mm]
- Friction disconnect
- Steel ball bearings
- Simple, fixed height bracket installation
- Lengths 12"–28" [305–711 mm]
- Clear zinc or black finish

# 2109

75-lb. [34 kg] load rating

*Keyboard trays, pencil drawers, and suspended drawers requiring a detent in and out.*

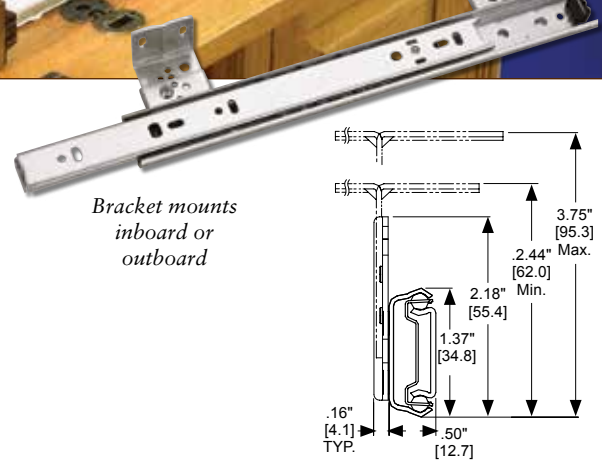

## SPECIFICATIONS

- 3/4 extension
- .50" [12.7 mm] side space (.66" [16.8 mm] with bracket)
- Drawer widths up to 16" [406 mm]
- Lever disconnect
- Steel ball bearings
- Even lengths 12"–28" [300–700 mm]
- Clear zinc or black finish

## SPECIAL FEATURES

- Hold-in and hold-out detent
- Variable height mounting brackets
- Flexibility of inboard or outboard bracket mounting

**Mounting bracket kit (zinc):**  
P/N 4180-0400-XE

**Mounting bracket kit (black):**  
P/N 4180-0401-XE

# Keyboard Systems

Ergonomically designed for home and business office workstations.



CBERGO-TRAY 200

## CBERGO-TRAY 200

- 3/4 extension slides
- Foam palm rest
- Angled keyboard

## SPECIFICATIONS

- Fully concealed slides ensure no rough or exposed edges
- Removable palm rest allows unit to accommodate virtually any size keyboard
- Extra-wide tray provides ample mousing surface
- Built-in cable management
- Removable mouse pad for left or right-handed mousing
- Typing surface held in place when in use or stored
- Mounting brackets feature seven adjustment heights and can be mounted inboard or outboard depending upon installation requirements
- Steel ball bearings

Side view shared for both models

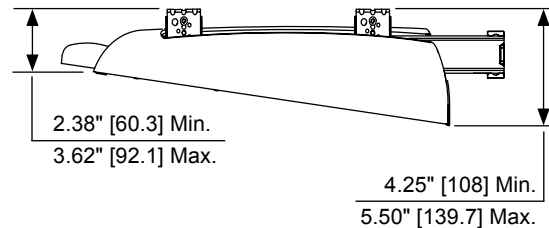

CBERGO-TRAY 200

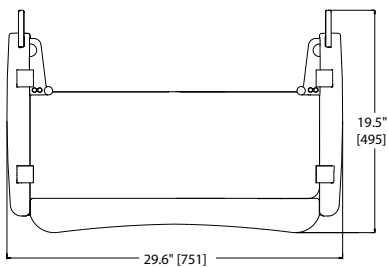

CBERGO-TRAY 300 - DELUXE

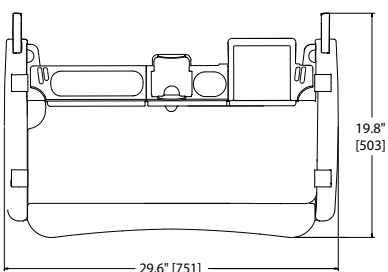

CBERGO-TRAY 300

## CBERGO-TRAY 300 - DELUXE

- Full extension slides
- Typing surface secures in partially or fully extended positions
- Gel palm rest
- Rear storage compartments
- Adjustable keyboard platform offers three typing positions for maximum user comfort

## 2019

75-lb. [34 kg] load rating

*Known as the quick-install shelf slide, this product has bent-down tabs to allow for platform-style shelf mounting.*

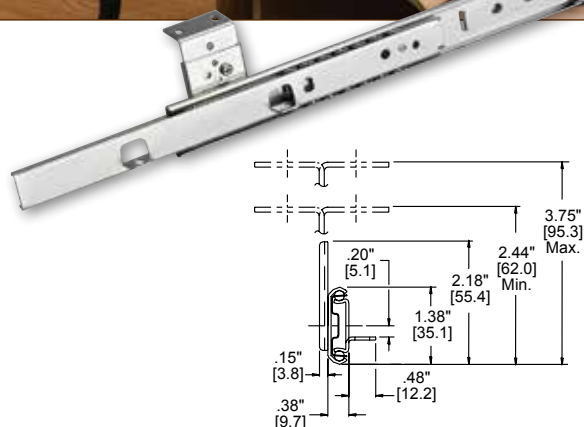

### SPECIFICATIONS

- 3/4 extension
- .38" [9.7 mm] side space
- Drawers up to 16" [406 mm] wide
- Lever disconnect
- Steel ball bearings
- Even lengths 12"-28" [305-711 mm]
- Clear zinc or black finish

### SPECIAL FEATURES

- Hold-out detent
- Optional bracket kit mounts in-board or out and provides up to 1.31" [33.2 mm] of vertical adjustment.

Optional bracket kit, zinc:

P/N 4180-0255-XE

Optional bracket kit, black:

P/N 4180-0257-XE

## 2002

50-lb. [23 kg] load rating

*This slide offers two-way travel, which works well on pass-through shelves, kitchen islands, and medical carts.*



### SPECIFICATIONS

- 3/4 extension
- .38" [9.7 mm] side space
- Drawers up to 12" [305 mm] wide
- Non-disconnect
- Steel ball bearings
- Even lengths 12"-28" [305-711 mm]
- Clear zinc or black finish

### SPECIAL FEATURES

- Shelf/bottom mount tabs
- Internal detent secures in center position
- Provides access from both sides of installation

# 0363

100-lb. [45 kg] load rating

*Offering full extension and two-way travel, this slide is for use in kitchen islands, dining or entertainment bars, or other cabinetry or carts that benefit from two-sided access.*

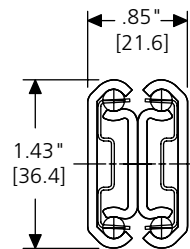

## SPECIFICATIONS

- Full extension from center point in both directions
- .85" [21.6 mm] side space
- Drawers up to 18" [457 mm] wide
- Non-disconnect
- Steel ball bearings
- Tested to 80,000 cycles
- Available lengths: 16", 20", 24", and 28" [400, 500, 600, 700 mm]
- Clear zinc finish

## SPECIAL FEATURES

- Two-way travel provides access from both sides of installation
- Hold-in detent at center keeps conveyances in position until use



## 322

100-lb. [45 kg] load rating

*This pull-out shelf slide is designed for entertainment center shelves, appliance drawers, and pan shelves.*

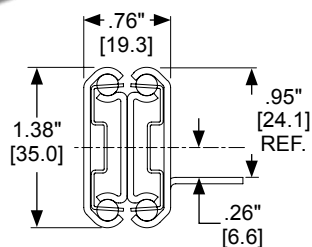

### SPECIFICATIONS

- Full extension + .88" [22.4 mm]
- .76" [19.3 mm] side space
- Drawers up to 16" [406 mm] wide
- Non-disconnect
- Tab mounting
- Steel ball bearings
- Even lengths 12"–28" [305–711 mm]
- Clear zinc or black finish

## 340

110-lb. [50 kg] load rating

*Known as the butcher block slide, model 340 is ideal for cutting boards, printer, and work surface shelves.*

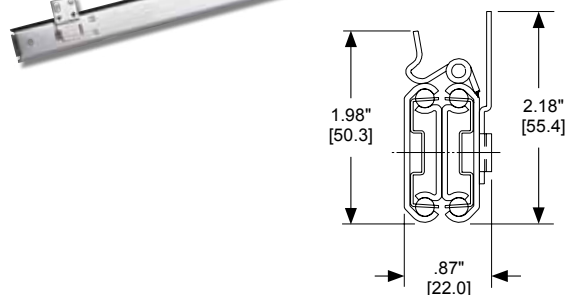

### SPECIFICATIONS

- Full extension
- .87" [22 mm] side space
- Drawers up to 18" [457 mm] wide
- Even lengths 16"–22" [406–559 mm]
- Steel ball bearings
- Clear zinc or black finish

### SPECIAL FEATURES

- Bracket mount/disconnect
- Easy disconnect for removal and work surface cleaning
- Lock-out secures slide in open position

## 301-2590

155-lb. [70 kg] load rating

Shelf or platform mounted pull-outs for pantries or entertainment centers.

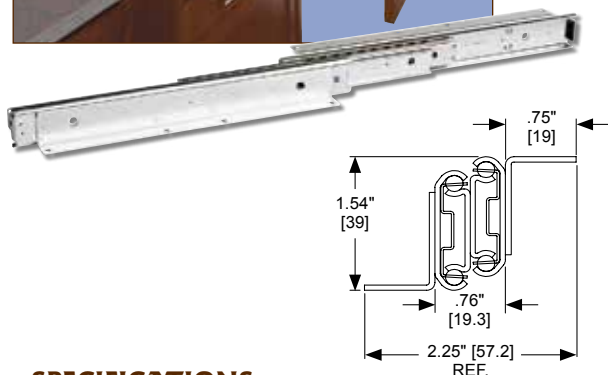

### SPECIFICATIONS

- .83" [21 mm] over travel
- 1.54" [39 mm] vertical space
- Drawers up to 16" [406 mm] wide
- Non-disconnect
- Steel ball bearings
- Even lengths 12"–28" [305–711 mm]
- Clear zinc or black finish

### SPECIAL FEATURES

- Mounts under shelves
- Hold-in detent to prevent drawer roll-out and bounce-back

## 3600-200/3600-201 StowAway

175-lb. [80 kg] load rating

Keep waste containers and utility bins in kitchens, laundry or hobby rooms neatly out of sight.



3600-201 Shown

### SPECIFICATIONS

- Full extension
- Drawers up to 20" [508 mm] wide
- Standard 22" length [559 mm]
- Steel ball bearings
- Clear zinc finish

### SPECIAL FEATURES

- Self-closing action begins within 2-1/2" [63.5 mm] from cabinet opening
- Handed lever disconnect
- Attached brackets permit side, top or bottom mounting

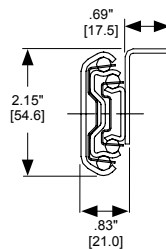

### 3600-200

- One fixed inboard bracket
- Outer member side-mounts directly onto cabinet wall

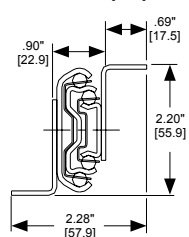

### 3600-201

- Inboard top bracket and outboard bottom bracket
- Slide may be mounted on top or bottom of the cabinet



**New!** **115RC**

**Linear Motion Track System**

*A simple motion solution comprised of aluminum tracks and re-circulating ball carriages. Use for movement and positioning of screens, panels, boards, or partitions.*

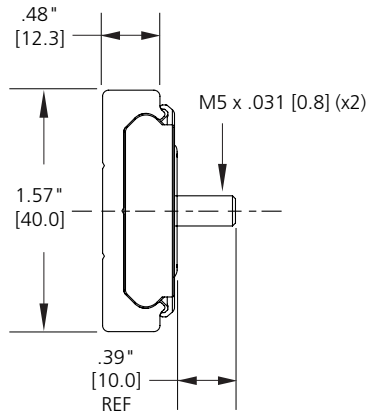
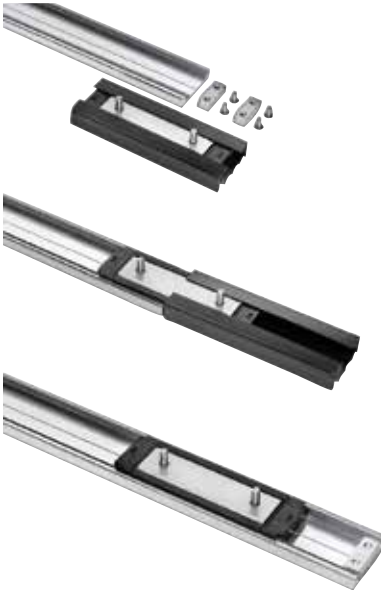

**FEATURES**

- Load rating up to 265 lbs. [120 kg]
- Load capacity based on track orientation and the type of ball carriages
- Corrosion-resistant components

**ALUMINUM TRACK**

- Available in two lengths: 47" [1.2 m] and 94" [2.4 m].
- Track may be cut down to the desired length or butted together to extend to greater lengths.
- Track may be side, flat, or vertically mounted.
- Flat-mounted track may be oriented with ball carriage facing up or down.
- Tracks have drilling marks for fixing holes and end stops.

**BALL CARRIAGES**

- Re-circulating ball carriages in two options:
  - Stainless steel ball bearings
  - Polymer ball bearings
- Multiple carriages may be inserted into tracks. Carriages may be used separately to provide independent movement, combined as a unit, or both methods within one track.

**OPTIONAL KITS**

**DZ0115-DJIGRC**

Drill Jig (made to order)

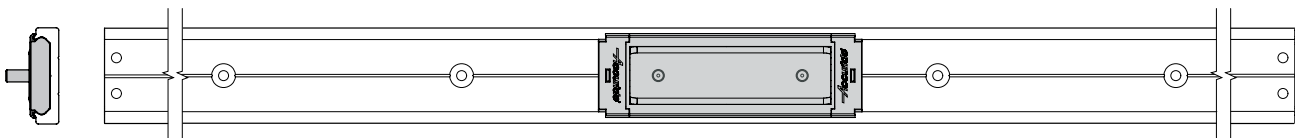

**Note:**

*Due to the extensive variety of applications and possible orientations for this product, we recommend that customers first test this product in the intended application. This product is not recommended for high-torque applications.*

**LOAD RATINGS**

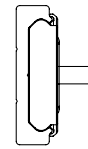

**SIDE MOUNT**

**SS0115-CASSRC    CB0115-CASSRC**

Stainless Steel Ball Carriage	Polymer Ball Carriage
x1 110 lbs.	x1 65 lbs.
x2 200 lbs.	x2 120 lbs.
x3 265 lbs.	x3 160 lbs.

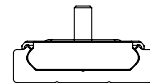

**FLAT MOUNT**

*(carriage up)*

**SS0115-CASSRC    CB0115-CASSRC**

Stainless Steel Ball Carriage	Polymer Ball Carriage
x1 65 lbs.	x1 40 lbs.
x2 120 lbs.	x2 70 lbs.
x3 155 lbs.	x3 90 lbs.

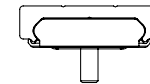

**FLAT MOUNT**

*(carriage down)*

**SS0115-CASSRC    CB0115-CASSRC**

Stainless Steel Ball Carriage	Polymer Ball Carriage
x1 90 lbs.	x1 50 lbs.
x2 155 lbs.	x2 90 lbs.
x3 200 lbs.	x3 120 lbs.

*NOTE: Weight should be evenly distributed across the carriage(s).*



# CB-Hand Locking Handle Kit

Adds lock-in and lock-out features to heavy-duty drawers or trays. Suitable for installations where the locking feature provides a measure of safety.

## SPECIFICATIONS

- Compatible with models such as 3640A, 7950, 7957, 9301, and other slides with cross sections .75" or greater [17.5mm].
- Accommodates drawers up to 60" (1.5 m) wide.
- One-hand operation: activates with a centrally located push-button.
- Two locking options:
  - Front mounted unit – lock-in only (CBHAND-2)
  - Rear mounted unit – lock-in and lock-out (CBHAN4-5)
- Connecting rod not included
- Lock-out not intended for use with over travel slides
- Cut-to-length stainless steel rods allow for varying drawer widths (ordered separately).

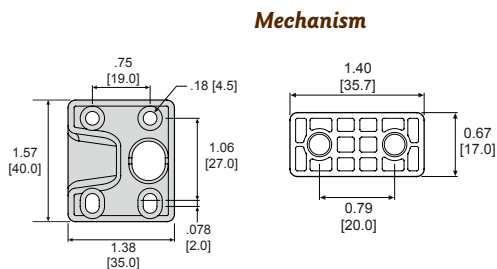
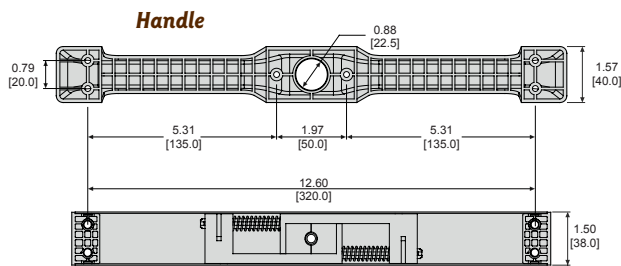

**Lock Block**

**Rod Support Block**

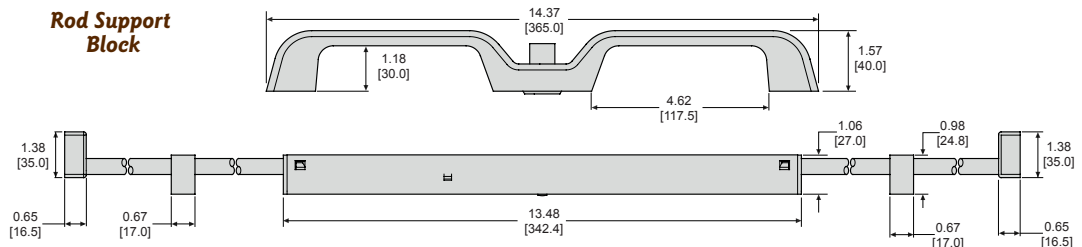

## SPECIAL FEATURES

- Lightweight and corrosion resistant components

## OPTIONAL KITS

### CBHAN4-5

Lock-out conversion kit

### CBHAN3-0100-2

2 ea. 19.7" [500 mm] Stainless Steel Rods

### CBHAN3-0150-2

2 ea. 29.5" [750 mm] Stainless Steel Rods

*NOTE: The addition of the lock-out kit requires an additional threaded bar (not included). See product technical sheet for details.*

# Limited Lifetime Warranty

Accuride International Inc. warrants its Accuride-branded drawer slides against defects in material and workmanship for so long as the original purchaser owns them.\* This warranty does not cover drawer slides which have been damaged due to abuse, improper installation, excessive loads, or any use contrary to the instructions accompanying the product. Accuride will send the original purchaser a replacement of the same model or a comparable model at no cost. This warranty is for replacement only and does not cover the cost of removal, installation, or incidental charges.

To obtain a replacement slide under this warranty, contact Accuride Technical Support within 30 days of the discovery of the defect. Please let us know how the product was used and the type of defect or malfunction experienced. Contact us by e-mail or phone at:

**Technical@accuride.com**  
or 562-903-0200, ext. 1436

The foregoing express limited warranty is in lieu of all other express warranties and excludes incidental or consequential damages. This warranty does not apply to products sold and used outside of the United States and Canada. All warranties implied by state law, including implied warranties of merchantability and fitness for a particular purpose, are expressly limited. Some states do not allow limitations on how long an implied warranty lasts or exclusion of incidental or consequential damages, so the foregoing limitation or exclusion may not apply to you. This Limited Lifetime Warranty gives you specific legal rights, and you may have other rights which vary from state to state.

\* This warranty does not apply to the cylinder for the Easy-Down® Flipper Door Slide®, CBERGO-TRAY Keyboard Systems, or any other Accuride product for which the expressed warranty differs from the Limited Lifetime Warranty offered above. Call Accuride Technical Support for further information.

**Accuride®**  
*Always Moving Forward*

**Notes:**

# Join us online!

These days it's easy to stay in touch with Accuride. You can subscribe to news, share products or information with friends, or visit us on Facebook and Twitter to join in the conversation.



## RSS

---

No time to stop by the site to see what's new? Subscribe to our RSS feed and we'll send you a note when there's a new product launched or an important announcement. To sign up for the news that's of interest to you, subscribe when you are on your market's page. For example, if you are interested in cabinet hardware for wood products, click on the RSS icon when you are on a "wood" page.



## SHARE

---

Find something cool you want to share with your boss, purchasing department, or poker buddies? Wherever you are on our site, when you click on the share button, you can share that page by email or with friends on your social network of choice, including sites such as Facebook, Twitter, or Delicious.



## OPT-IN E-MAIL SUBSCRIPTION

---

Want to get on our mailing list? We'll never spam you—promise! We only send out announcements when we have a new product or special news to share.

## TWITTER AND FACEBOOK

---

Yes, we've jumped on the social media bandwagon and we'd love to have you join us. We've set up market-specific pages so you can follow (and comment on!) the information that's most meaningful to you.

Here are the links:



Woodworking: <http://bit.ly/accurideww>  
Architectural: <http://bit.ly/accuridearch>



Woodworking: <http://twitter.com/accurideww>  
Architectural: <http://twitter.com/accuridearch>

See you online!

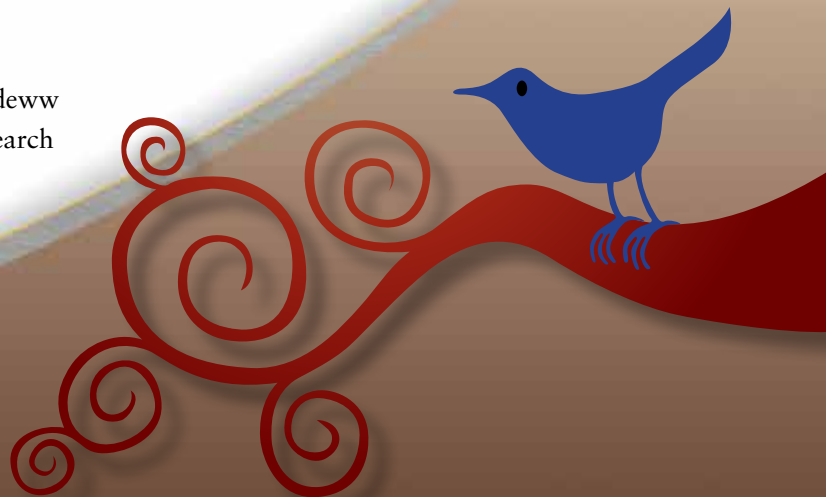



## ACCURIDE INTERNATIONAL INC.

### NORTH AMERICA

INTERNATIONAL HEADQUARTERS  
12311 Shoemaker Avenue  
Santa Fe Springs, California 90670  
562 903-0200 Telephone  
562 903-0208 Fax  
[www accuride.com](http://www accuride.com)

Calle Circuito Norte No. 6  
Parque Industrial Nelson  
Mexicali, B.C., C.P. 21395 Mexico

### EUROPE

Postfach 1464  
Werner - Von Siemens - Strasse 16-18  
65582 Diez/Lahn  
Germany  
(49 64 32) 6 08-0 Telephone  
(49 64 32) 6 08-20 Fax  
[www accuride-europe.com](http://www accuride-europe.com)

Liliput Road  
Brackmills Industrial Estate  
Northampton, NN4 7AS  
United Kingdom  
(441) 604-761111 Telephone  
(441) 604-767190 Fax  
[www accuride-europe.com](http://www accuride-europe.com)

### ASIA

Accuride Japan Co., Ltd.  
44 Minami-asaji Iwata Yawata-shi  
Kyoto, Japan  
81-75-983-7500 Telephone  
81-75-983-9500 Fax  
[www accuride.co.jp](http://www accuride.co.jp)

Accuride International Suzhou Co. LTD  
No. 178, Suhong East Road  
Suzhou Industrial Park  
Jiangsu Province, China 215026  
86-512-62731200 Telephone  
86-512-62833993 Fax  
[www accuride.com.cn](http://www accuride.com.cn)

DISTRIBUTED BY:

Follow us

